



# FORGED MOTORCYCLE PISTONS & PARTS



2014



*Offroad  
ATV  
Street*





Wir sind die innovativen Spezialisten für Hochleistungskolben und Pleuel. Wössner Produkte arbeiten in Motoren auf dem höchsten Level des Motorsports, sowie im täglichen Gebrauch – überall dort wo Leistung und Langlebigkeit sehr wichtige Faktoren sind. Dabei werden unterschiedliche Kolben für den Rennsport und für den täglichen Gebrauch produziert, um die jeweils speziellen Anforderung der Motoren optimal zu erfüllen. Der Erfolg berühmter Motorsportteams in nationalen und internationalen Wettbewerben basiert oft auf der überlegenen Leistung der Wössner Produkte.

We are the innovative specialists for high performance pistons and conrods. Our products are to be found in engines operating at the highest levels of motor sport, in competition and, of course, in everyday use – in fact, anywhere where longevity and operational noise are important factors. Wössner products are the source of the superior power behind the success of well known motor sport teams at national and international race meets.

# FORGED MOTORCYCLE PISTONS & MOTORCYCLE PARTS

## OFFROAD

Bultaco®	2 stroke	5
Can Am®	4 stroke	6
GasGas®	2 stroke	7 - 10
GasGas®	4 stroke	11 - 13
Honda®	2 stroke	14 - 25
Honda®	4 stroke	26 - 36
Husaberg®	2 stroke	37
Husaberg®	4 stroke	38 - 43
Husqvarna®	2 stroke	44 - 50
Husqvarna®	4 stroke	51 - 58
Kawasaki®	2 stroke	59 - 70
Kawasaki®	4 stroke	71 - 77
KTM®	2 stroke	78 - 89
KTM®	4 stroke	90 - 101
Maico®	2 stroke	102 - 103
Rotax®	2 stroke	104
Suzuki®	2 stroke	105 - 117
Suzuki®	4 stroke	118 - 124
TM®	2 stroke	125 - 126
TM®	4 stroke	127 - 129
VOR®	4 stroke	130
Yamaha®	2 stroke	131 - 146
Yamaha®	4 stroke	147 - 157

## ATV

GasGas®	2 stroke	158
GasGas®	4 stroke	159
Honda®	2 stroke	160
Honda®	4 stroke	161 - 165
Husaberg®	4 stroke	166
Kawasaki®	2 stroke	167
Kawasaki®	4 stroke	168 - 170
Polaris®	2 stroke	171 - 172
Polaris®	4 stroke	173 - 174
Suzuki®	2 stroke	175 - 176
Suzuki®	4 stroke	177 - 178
Yamaha®	2 stroke	179 - 181
Yamaha®	4 stroke	182 - 185

## STREET

Aprilia®	2 stroke	186 - 187
BMW®	4 stroke	188 - 190
Cagiva®	2 stroke	191
Ducati®	4 stroke	192 - 194
Honda®	2 stroke	195 - 196
Honda®	4 stroke	197 - 199
Kawasaki®	2 stroke	200 - 201
Kawasaki®	4 stroke	202 - 207
Sachs®	2 stroke	208
Suzuki®	2 stroke	209
Suzuki®	4 stroke	210 - 214
Yamaha®	4 stroke	215 - 217

## SPEEDWAY

GM®	4 stroke	218
-----	----------	-----

Pleuel • Conrods - 2 stroke	219 - 220
Pleuel • Conrods - 4 stroke	221 - 222
Nadellager • Needle Bearings	223 - 228
Kurbelwellenlager • Main Bearings	229 - 238
Dichtungen • Top End Gaskets - 2 stroke	234
Dichtungen • Top End Gaskets - 4 stroke	235
Ringe • Rings - 2 stroke	236 - 237
Ringe • Rings - 4 stroke	238 - 240
Bolzen • Pins	241 - 243

FGM Forging Group Monale - Italy	244 - 245
Installationshinweise •	
Installation Instructions	246
Bestellformulare • Order forms	247 - 248
AGB's • General Terms and Conditions	249 - 250
Gewährleistungen • Warranty Disclaimer	251

Fehler und Änderungen, sowie Preisänderungen vorbehalten.  
*Errors and changes, as well as changes in prices excepted.*



## PISTONS

### PERFORMANCE

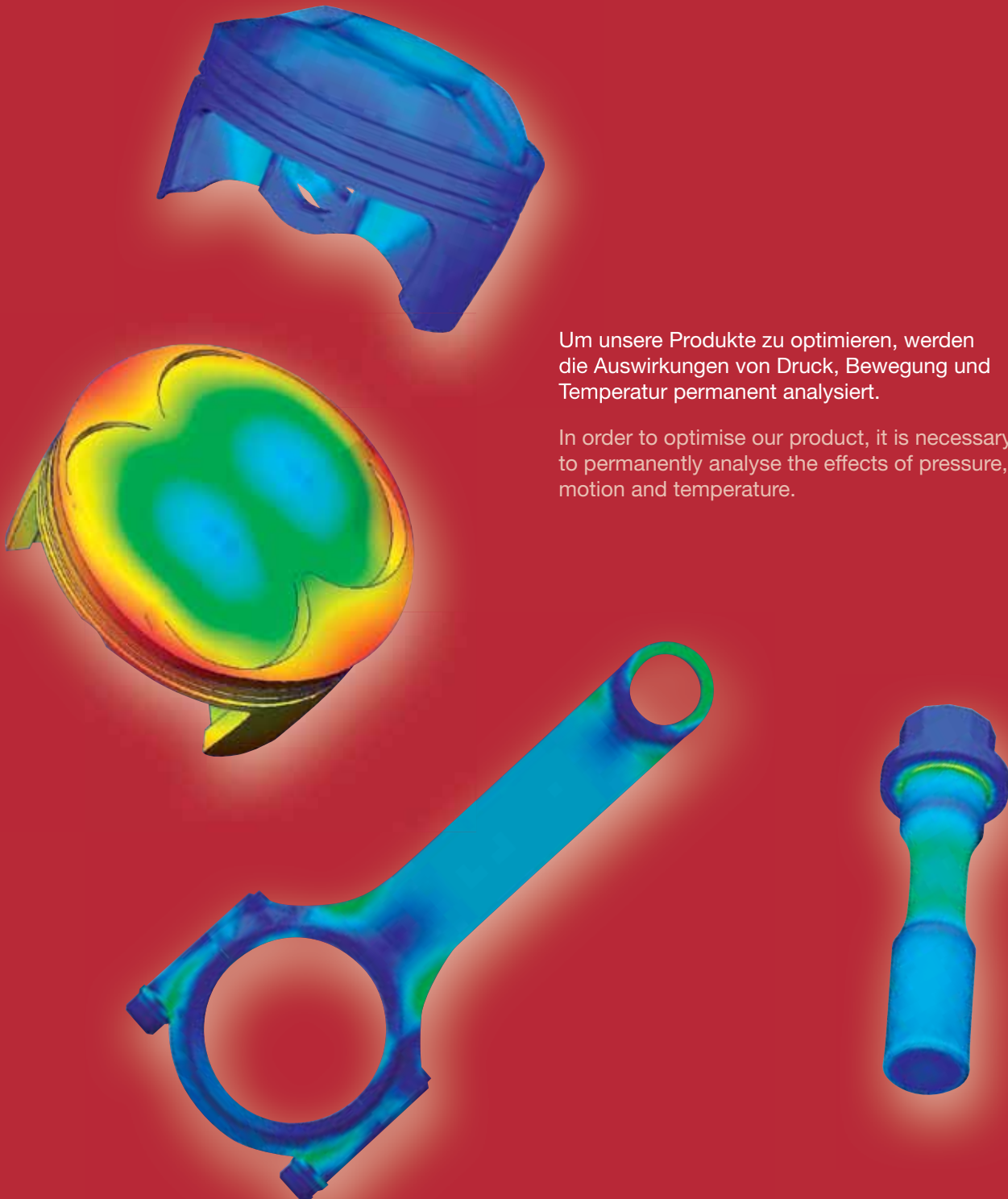

Um unsere Produkte zu optimieren, werden die Auswirkungen von Druck, Bewegung und Temperatur permanent analysiert.

In order to optimise our product, it is necessary to permanently analyse the effects of pressure, motion and temperature.

## BETAMOTOR - 4 stroke



Model	RR250 <b>New!</b>	RR450 <b>New!</b>	RR525 <b>New!</b>
Years	05-07	05-09	05-09
Displ. (cc)	249	449	510

Piston Kit Part No.	Piston size (mm)	Over size (mm)	Ring Set Part No.	Piston Kit Part No.	Piston size (mm)	Over size (mm)	Ring Set Part No.	Piston Kit Part No.	Piston size (mm)	Over size (mm)	Ring Set Part No.
8592DA	74,95	Std.	750XDS	8581DA	88,96	Std.	890XSY	8547DA	94,95	Std.	950ADS-2
8592DB	74,96	+0,01	750XDS	8581DB	88,97	+0,01	890XSY	8547DB	94,96	+0,01	950ADS-2
8592DC	74,97	+0,02	750XDS	8581DC	88,98	+0,02	890XSY	8547DC	94,97	+0,02	950ADS-2
								8547D200	96,95	+2,00	950ADS-2

	set includes		
Clip Part No.	CW20	CW20	CW20
Pin Part No.	WP029	WP038	WP073
Rings	included	included	included
Price-Code	5/1	7	7/1
Stroke	56.5	72	72
Wössner/ OEM Comp. ratio	- 12:1	11.1:1 11.1:1	- 11:1
Dome Volume (CC)	-4.1 cm <sup>3</sup>	+7.1 cm <sup>3</sup>	-2.1 cm <sup>3</sup>
Comp. Height (mm)	25.3	23.5	23.5

	extra parts		
Top End Gasket Kit	-	-	D4021-EST
Wössner Connecting rods	P4048	P4048	P4048
Needle bearing	-	-	-
Main bearing	2 x MBNJ206	2 x MBNJ206	2 x MBNJ206

## BETAMOTOR - 4 stroke



**New!**

Model	RR525 Pro Series
Years	05-09
Displ. (cc)	510

Piston Kit Part No.	Piston size (mm)	Over size (mm)	Ring Set Part No.
8637DA	94,95	Std.	950ADS-2
8637DB	94,96	+0,01	950ADS-2
8637DC	94,97	+0,02	950ADS-2
8637D200	96,95	+2,00	970ADS-2
8637D400	98,95	+4,00	990XSY

set includes	
Clip Part No.	CW20
Pin Part No.	WP029
Rings	included
Price-Code	7/1
Stroke	72
Wössner/ OEM Comp. ratio	12.5:1 11:1
Dome Volume (CC)	+4.61 cm <sup>3</sup>
Comp. Height (mm)	23.5

extra parts	
Top End Gasket Kit	D4021-EST
Wössner Connecting rods	P4048
Needle bearing	-
Main bearing	2 x MBNJ206

## Bultaco® - 2 stroke



**New!**

Model	TS250
Years	-
Displ. (cc)	-

Piston Kit Part No.	Piston size (mm)	Over size (mm)	Ring Set Part No.
8291DA	71,94	Std.	RSB7200
8291D050	72,44	+0,50	RSB7250
8291D100	72,94	+1,00	RSB7300
8291D150	73,44	+1,50	RSB7350
8291D200	73,94	+2,00	RSB7400

set includes	
Clip Part No.	CW16
Pin Part No.	WP027
Rings	included
Price-Code	3
Stroke	-
Comp. Height (mm)	-

extra parts	
Top End Gasket Kit	-
Wössner Connecting rods	-
Needle bearing	-
Main bearing	-



Pavel Kejmar Deutscher Meister 2012 in der S1  
Internationale Deutsche Supermoto Meisterschaft 2012  
Team Bauerschmidt KTM

## Can-Am - 4 stroke



Verdichtungen beziehen sich auf Standardmaße „-DA“

Compression ratio refer to standard sizes “-DA”

Model	DS450 / DS450X Pro Series
Years	08-12
Displ. (cc)	449

Piston Kit Part No.	Piston size (mm)	Over size (mm)	Ring Set Part No.
8864DA	96,95	Std.	970XSY

set includes	
Clip Part No.	CW20
Pin Part No.	WP068
Rings	included
Price-Code	7
Stroke	60
Wössner/ OEM Comp. ratio	13.5:1 12.5:1
Dome Volume (cc)	-0.5 cm <sup>3</sup>
Comp. Height (mm)	26.8

extra parts	
Top End Gasket Kit	-
Wössner Connecting rods	-
Needle bearing	-
Main bearing	-



## GasGas® - 2 stroke



Model	MC125 flat top	EC125 domed	TXT125
Years	00-11	00-11	03-09
Displ. (cc)	124	124	124

Piston Kit Part No.	Piston size (mm)	Over size (mm)	Ring Set Part No.	Piston Kit Part No.	Piston size (mm)	Over size (mm)	Ring Set Part No.	Piston Kit Part No.	Piston size (mm)	Over size (mm)	Ring Set Part No.
8080DA	53,95	Std.	RSB5400	8079DA	53,95	Std.	RSB5400	8218DA	53,95	Std.	RDB5400
8080DB	53,96	+0,01	RSB5400	8079DB	53,96	+0,01	RSB5400	8218DB	53,96	+0,01	RDB5400
8080DC	53,97	+0,02	RSB5400	8079DC	53,97	+0,02	RSB5400	8218DC	53,97	+0,02	RDB5400

	set includes		
Clip Part No.	CW15	CW15	CW16
Pin Part No.	WP032	WP032	WP036
Rings	included	included	included
Price-Code	2	2	2
Stroke	54,5	54,5	54,5
Comp. Height (mm)	28	28	29,5

	extra parts		
Top End Gasket Kit	D2042-EST	D2042-EST	-
Wössner Connecting rods	-	-	-
Needle bearing	N1011	N1011	-
Main bearing	2 x MB6322C4	2 x MB6322C4	-

## GasGas® - 2 stroke



Model	EC200	TXT200	MC250 / EC250
Years	03-09	99-06	97-11
Displ. (cc)	199	175	249

Piston Kit Part No.	Piston size (mm)	Over size (mm)	Ring Set Part No.	Piston Kit Part No.	Piston size (mm)	Over size (mm)	Ring Set Part No.	Piston Kit Part No.	Piston size (mm)	Over size (mm)	Ring Set Part No.
8139DA	62,45	Std.	RDB6250	8132DA	63,95	Std.	RDB6400	8052DA	66,33	Std.	RDB6640
8139DB	62,46	+0,01	RDB6250	8132DB	63,96	+0,01	RDB6400	8052DB	66,34	+0,01	RDB6640
8139DC	62,47	+0,02	RDB6250	8132DC	63,97	+0,02	RDB6400	8052DC	66,35	+0,02	RDB6640
								8052DD	66,36	+0,03	RDB6640

	set includes		
Clip Part No.	CW18	CW16	CW18
Pin Part No.	WP040	WP027	WP033
Rings	included	included	included
Price-Code	3	3/1	3
Stroke	65	54,5	72
Comp. Height (mm)	32	30	38

	extra parts		
Top End Gasket Kit	-	-	D2053-EST
Wössner Connecting rods	-	-	P2021 '97-14
Needle bearing	N1020	-	N1021
Main bearing	-	-	-

## GasGas® - 2 stroke



Model	TXT250	TXT280 / MT280	EC300
Years	02-14	all	00-14
Displ. (cc)	247	272	297

Piston Kit Part No.	Piston size (mm)	Over size (mm)	Ring Set Part No.	Piston Kit Part No.	Piston size (mm)	Over size (mm)	Ring Set Part No.	Piston Kit Part No.	Piston size (mm)	Over size (mm)	Ring Set Part No.
8163DA	72,46	Std.	RDB7250	8144DA	76,00	Std.	RDC7600	8077DA	71,93	Std.	RDB7200
8163DB	72,47	+0,01	RDB7250	8144DB	76,01	+0,01	RDC7600	8077DB	71,94	+0,01	RDB7200
8163DC	72,48	+0,02	RDB7250	8144DC	76,02	+0,02	RDC7600	8077DC	71,95	+0,02	RDB7200

set includes			
Clip Part No.	CA18	CA18	CW18
Pin Part No.	WP033	WP033	WP033
Rings	included	included	included
Price-Code	3/1	6	6
Stroke	60	60	72,5
Comp. Height (mm)	28.75	28.75	38

extra parts			
Top End Gasket Kit	-	-	D2053-EST
Wössner Connecting rods	-	-	P2021
Needle bearing	-	-	N1021
Main bearing	-	-	-

## GasGas® - 2 stroke



Model	TXT300
Years	all
Displ. (cc)	294

Piston Kit Part No.	Piston size (mm)	Over size (mm)	Ring Set Part No.
8145DA	78,96	Std.	RDC7900
8145DB	78,97	+0,01	RDC7900
8145DC	78,98	+0,02	RDC7900

set includes	
Clip Part No.	CA18
Pin Part No.	WP033
Rings	included
Price-Code	6/1
Stroke	60
Comp. Height (mm)	28.75

extra parts	
Top End Gasket Kit	-
Wössner Connecting rods	-
Needle bearing	-
Main bearing	-

## GasGas® - 4 stroke



Verdichtungen beziehen sich auf Standardmaße „-DA“

Compression ratio refer to standard sizes “-DA”

**New!**

Model	EC250F Std-Compr. 3.Ring	EC250F Pro Serie 2.Ring	EC300F
Years	10-14	10-14	13-14
Displ. (cc)	249	249	290

Piston Kit Part No.	Piston size (mm)	Over size (mm)	Ring Set Part No.	Piston Kit Part No.	Piston size (mm)	Over size (mm)	Ring Set Part No.	Piston Kit Part No.	Piston size (mm)	Over size (mm)	Ring Set Part No.
8614DA	76,96	Std.	770XAS-2	8612DA	76,96	Std.	770XAS-2	8875DA	82,94	Std.	830XDS
8614DB	76,97	+0,01	770XAS-2	8612DB	76,97	+0,01	770XAS-2	8875DB	82,95	+0,01	830XDS
8614DC	76,98	+0,02	770XAS-2	8612DC	76,98	+0,02	770XAS-2	8875DC	82,96	+0,02	830XDS
8614D200	78,96	+2,00	790XMS								

	set includes		
Clip Part No.	CW16	CW16	CW16
Pin Part No.	WP059	WP059	WP059
Rings	included	included	included
Price-Code	5	5/1	7
Stroke	53.6	53.6	53.6
Wössner/ OEM Comp. ratio	12.5:1	- 13.5:1	13.5:1 13.5:1
Dome Volume (CC)	-4.5 cm <sup>3</sup>	-2.8 cm <sup>3</sup>	-6.3 cm <sup>3</sup>
Comp. Height (mm)	22.2	22.2	22.2

	extra parts		
Top End Gasket Kit	-	-	-
Wössner Connecting rods	P4005 `10-14	P4005 `10-14	-
Needle bearing	-	-	-
Main bearing	-	-	-

## GasGas® - 4 stroke



Verdichtungen beziehen sich auf Standardmaße „-DA“  
 Compression ratio refer to standard sizes “-DA”

Model	HP450 / EC450 / FSE450	HP450 / EC450 / FES450	HP450 / EC450 / FES450
Years	03-04	05	06-09
Displ. (cc)	443	443	449

Piston Kit Part No.	Piston size (mm)	Over size (mm)	Ring Set Part No.	Piston Kit Part No.	Piston size (mm)	Over size (mm)	Ring Set Part No.	Piston Kit Part No.	Piston size (mm)	Over size (mm)	Ring Set Part No.
8585DA	94,95	Std.	950XSY	8615DA	94,95	Std.	950ADS-2	8638DA	96,95	Std.	970ADS-2
8585DB	94,96	+0,01	950XSY	8615DB	94,96	+0,01	950ADS-2	8638DB	96,96	+0,01	970ADS-2
8585DC	94,97	+0,02	950XSY	8615DC	94,97	+0,02	950ADS-2	8638DC	96,97	+0,02	970ADS-2

	set includes		
Clip Part No.	CW20	CW20	CW20
Pin Part No.	WP038	WP038	WP038
Rings	included	included	included
Price-Code	7/1	7/1	7
Stroke	62.60	62.60	60.80
Wössner/ OEM Comp. ratio	-	-	-
Dome Volume (CC)	-6.4 cm <sup>3</sup>	-6.4 cm <sup>3</sup>	-2.8 cm <sup>3</sup>
Comp. Height (mm)	25.50	25.50	25.50

	extra parts		
Top End Gasket Kit	-	-	-
Wössner Connecting rods	-	-	-
Needle bearing	-	-	-
Main bearing	-	-	-

## GasGas® - 4 stroke



Verdichtungen beziehen sich auf Standardmaße „-DA“

Compression ratio refer to standard sizes “-DA”

Model	EC450F <b>New!</b>	EC450F Pro Series <b>New!</b>	SM450
Years	13-14	13-14	07-09
Displ. (cc)	449	449	449

Piston Kit Part No.	Piston size (mm)	Over size (mm)	Ring Set Part No.	Piston Kit Part No.	Piston size (mm)	Over size (mm)	Ring Set Part No.	Piston Kit Part No.	Piston size (mm)	Over size (mm)	Ring Set Part No.
8630DA	94,96	Std.	950ADS-2	8631DA	94,96	Std.	950ADS-2	8638DA	96,95	Std.	970ADS-2
8630DB	94,97	+0,01	950ADS-2	8631DB	94,97	+0,01	950ADS-2	8638DB	96,96	+0,01	970ADS-2
8630DC	94,98	+0,02	950ADS-2	8631DC	94,98	+0,02	950ADS-2	8638DC	96,97	+0,02	970ADS-2

	set includes		
Clip Part No.	CW18	CW18	CW20
Pin Part No.	WP053	WP053	WP038
Rings	included	included	included
Price-Code	7	7	7
Stroke	63.4	63.4	60.80
Wössner/ OEM Comp. ratio	12.3:1 12.3:1	13.5:1 12.3:1	-
Dome Volume (CC)	-9.7 cm <sup>3</sup>	-6.1 cm <sup>3</sup>	-2.8 cm <sup>3</sup>
Comp. Height (mm)	23.50	23.50	25.50

	extra parts		
Top End Gasket Kit	D4031-EST	D4031-EST	-
Wössner Connecting rods	P4008	P4008	-
Needle bearing	-	-	-
Main bearing	2 x MB83C072C	2 x MB83C072C	-

## Honda® - 2 stroke



Model	CR80	CR80 U.S Bore	CR80 International Bore
Years	86-91	92-02	86-02
Displ. (cc)	80	80	80

Piston Kit Part No.	Piston size (mm)	Over size (mm)	Ring Set Part No.	Piston Kit Part No.	Piston size (mm)	Over size (mm)	Ring Set Part No.	Piston Kit Part No.	Piston size (mm)	Over size (mm)	Ring Set Part No.
8238DA	46,95	Std.	RSB4700	8237DA	46,95	Std.	RSB4700	8230DA	45,95	Std.	RSB4600
8238D050	47,45	+0,50	RSB4750	8237D050	47,45	+0,50	RSB4750	8230DB	45,96	+0,01	RSB4600
8238D100	47,95	+1,00	RSB4800	8237D100	47,95	+1,00	RSB4800	8230DC	45,97	+0,02	RSB4600
8238D200	48,95	+2,00	RSB4900	8237D200	48,95	+2,00	RSB4900				

	set includes		
Clip Part No.	CW14	CW14	CW14
Pin Part No.	WP058	WP058	WP058
Rings	included	included	included
Price-Code	1/1	1/1	1/1
Stroke	47.8	47.8	47.8
Comp. Height (mm)	24	24	24

	extra parts		
Top End Gasket Kit	-	-	-
Wössner Connecting rods	P2003	P2003	P2003
Needle bearing	N1006	N1006	N1006
Main bearing	2 x MB6322C4	-	-



## Honda® - 2 stroke



Model	CR80R	CR80R	CR80R
Years	80-82	83	84
Displ. (cc)	79,7	79,7	79,7

Piston Kit Part No.	Piston size (mm)	Over size (mm)	Ring Set Part No.	Piston Kit Part No.	Piston size (mm)	Over size (mm)	Ring Set Part No.	Piston Kit Part No.	Piston size (mm)	Over size (mm)	Ring Set Part No.
8277DA	49,45	Std.	RDB4950	8278DA	49,45	Std.	RDB4950	8279DA	49,45	Std.	RDB4950
8277D050	49,95	+0,50	RDB5000	8278D050	49,95	+0,50	RDB5000	8279D050	49,95	+0,50	RDB5000
8277D100	50,45	+1,00	RDB5050	8278D100	50,45	+1,00	RDB5050	8279D100	50,45	+1,00	RDB5050
8277D150	50,95	+1,50	RDB5100	8278D150	50,95	+1,50	RDB5100	8279D150	50,95	+1,50	RDB5100
8277D200	51,45	+2,00	RDB5150	8278D200	51,45	+2,00	RDB5150	8279D200	51,45	+2,00	RDB5150

set includes			
Clip Part No.	CW12	CW12	CW12
Pin Part No.	WP091	WP091	WP091
Rings	included	included	included
Price-Code	1/1	1/1	1/1
Stroke	41.4	41.4	41.4
Comp. Height (mm)	27	25	25

extra parts			
Top End Gasket Kit	-	-	-
Wössner Connecting rods	-	-	-
Needle bearing	N1004	N1004	N1004
Main bearing	-	-	-

## Honda® - 2 stroke



Model	CR80R	CR85	CR125 / MT125
Years	85	03-07	73-78
Displ. (cc)	82,9	84,7	123

Piston Kit Part No.	Piston size (mm)	Over size (mm)	Ring Set Part No.	Piston Kit Part No.	Piston size (mm)	Over size (mm)	Ring Set Part No.	Piston Kit Part No.	Piston size (mm)	Over size (mm)	Ring Set Part No.
8280DA	46,95	Std.	RDB4700	8105DA	47,45	Std.	RSB4750	8151DA	55,94	Std.	RDB5600
8280D050	47,45	+0,50	RDB4750	8105DB	47,46	+0,01	RSB4750	8151D050	56,44	+0,50	RDB5650
8280D100	47,95	+1,00	RDB4800	8105DC	47,47	+0,02	RSB4750	8151D100	56,94	+1,00	RDB5700
8280D150	48,45	+1,50	RDB4850					8151D150	57,44	+1,50	RDB5750
8280D200	48,95	+2,00	RDB4900					8151D200	57,94	+2,00	RDB5800

	set includes		
Clip Part No.	CW13	CW14	CW14
Pin Part No.	WP088	WP058	WP025
Rings	included	included	included
Price-Code	1/1	1	2/1
Stroke	47.8	47.8	50
Comp. Height (mm)	25	24	28.8

	extra parts		
Top End Gasket Kit	-	D2001-EST	-
Wössner Connecting rods	-	P2003	-
Needle bearing	N1004	N1006	N1008
Main bearing	-	2 x MB6322C4	-

## Honda® - 2 stroke



Model	CR125	CR125	CR125
Years	79	80-84	85-86
Displ. (cc)	123	120	124

Piston Kit Part No.	Piston size (mm)	Over size (mm)	Ring Set Part No.	Piston Kit Part No.	Piston size (mm)	Over size (mm)	Ring Set Part No.	Piston Kit Part No.	Piston size (mm)	Over size (mm)	Ring Set Part No.
8150DA	55,94	Std.	RDB5600	8149DA	55,44	Std.	RDB5550	8127DA	53,94	Std.	RDB5400
8150D050	56,44	+0,50	RDB5650	8149D050	55,94	+0,50	RDB5600	8127D025	54,19	+0,25	RDB5425
8150D100	56,94	+1,00	RDB5700	8149D100	56,44	+1,00	RDB5650	8127D050	54,44	+0,50	RDB5450
8150D150	57,44	+1,50	RDB5750	8149D125	56,69	+1,25	RDB5675	8127D075	54,69	+0,75	RDB5475
				8149D150	56,94	+1,50	RDB5700	8127D100	54,94	+1,00	RDB5500
				8149D200	57,44	+2,00	RDB5750	8127D125	55,19	+1,25	RDB5525
								8127D150	55,44	+1,50	RDB5550
								8127D200	55,94	+2,00	RDB5600

	set includes		
Clip Part No.	CW14	CW14	CW14
Pin Part No.	WP025	WP025	WP025
Rings	included	included	included
Price-Code	2/1	2/1	2/1
Stroke	50	50	54
Comp. Height (mm)	28.5	28.5	28

	extra parts		
Top End Gasket Kit	-	-	-
Wössner Connecting rods	-	P2040 '83-84	P2041
Needle bearing	N1008	N1008	N1007
Main bearing	2 x MB6304C3	2 x MB6322C4	2 x MB6322C4

## Honda® - 2 stroke



Model	CR125	CR125	CR125
Years	87	88-89	90-91
Displ. (cc)	124	125	125

Piston Kit Part No.	Piston size (mm)	Over size (mm)	Ring Set Part No.	Piston Kit Part No.	Piston size (mm)	Over size (mm)	Ring Set Part No.	Piston Kit Part No.	Piston size (mm)	Over size (mm)	Ring Set Part No.
8126DA	53,94	Std.	RSB5400	8125DA	53,94	Std.	RSB5400	8107DA	53,94	Std.	RSB5400
8126D050	54,44	+0,50	RSB5450	8125D050	54,44	+0,50	RSB5450	8107DB	53,95	+0,01	RSB5400
8126D100	54,94	+1,00	RSB5500	8125D100	54,94	+1,00	RSB5500	8107DC	53,96	+0,02	RSB5400
8126D125	55,19	+1,25	RSB5525	8125D125	55,19	+1,25	RSB5525	8107D050	54,44	+0,50	RSB5450
8126D150	55,44	+1,50	RSB5550	8125D150	55,44	+1,50	RSB5550	8107D100	54,94	+1,00	RSB5500
8126D200	55,94	+2,00	RSB5600	8125D200	55,94	+2,00	RSB5600				

	set includes		
Clip Part No.	CW14	CW15	CW15
Pin Part No.	WP025	WP032	WP032
Rings	included	included	included
Price-Code	2/1	2/1	2
Stroke	54	54.5	54.5
Comp. Height (mm)	28	28	28

	extra parts		
Top End Gasket Kit	-	-	D2002-EST
Wössner Connecting rods	P2041	P2009	P2009
Needle bearing	N1008	N1047	N1047
Main bearing	2 x MB6322C4	2 x MB6322C4	2 x MB6322C4

## Honda® - 2 stroke



<b>Model</b>	CR125	CR125	CR125
<b>Years</b>	92-99	00-03	04
<b>Displ. (cc)</b>	125	125	125

Piston Kit Part No.	Piston size (mm)	Over size (mm)	Ring Set Part No.	Piston Kit Part No.	Piston size (mm)	Over size (mm)	Ring Set Part No.	Piston Kit Part No.	Piston size (mm)	Over size (mm)	Ring Set Part No.
8020DA	53,95	Std.	RSB5400	8067DA	53,95	Std.	RSB5400	8100DA	53,95	Std.	RSB5400
8020DB	53,96	+0,01	RSB5400	8067DB	53,96	+0,01	RSB5400	8100DB	53,96	+0,01	RSB5400
8020DC	53,97	+0,02	RSB5400	8067DC	53,97	+0,02	RSB5400	8100DC	53,97	+0,02	RSB5400
8020DD	53,98	+0,03	RSB5400	8067D050	54,45	+0,50	RSB5450	8100D200	55,95	+2,00	RSB5600
8020D050	54,45	+0,50	RSB5450	8067D100	54,95	+1,00	RSB5500	for D200 no Top End Gasket available			
8020D100	54,95	+1,00	RSB5500								

	set includes		
<b>Clip Part No.</b>	CW15	CW15	CW15
<b>Pin Part No.</b>	WP032	WP032	WP032
<b>Rings</b>	included	included	included
<b>Price-Code</b>	2	2	2/1
<b>Stroke</b>	54.5	54.5	54.5
<b>Comp. Height (mm)</b>	28	28	28

	extra parts		
<b>Top End Gasket Kit</b>	D2002-EST `90-97 D2003-EST `98-99	D2004-EST `00-02 D2005-EST `03	D2006-EST `04
<b>Wössner Connecting rods</b>	P2009	P2009	P2009
<b>Needle bearing</b>	N1047	N1047	N1047
<b>Main bearing</b>	2 x MB6322C4	2 x MB6322C4	2 x MB6322C4

## Honda® - 2 stroke



Model	CR125	MBX125 / MTX125	MTX125 Rally
Years	05-07	83-87	88-90
Displ. (cc)	125	124	124

Piston Kit Part No.	Piston size (mm)	Over size (mm)	Ring Set Part No.	Piston Kit Part No.	Piston size (mm)	Over size (mm)	Ring Set Part No.	Piston Kit Part No.	Piston size (mm)	Over size (mm)	Ring Set Part No.
8170DA	53,95	Std.	RSB5400	8024DA	55,94	Std.	RDB5600	8190DA	55,96	Std.	RDB5600
8170DB	53,96	+0,01	RSB5400	8024D050	56,44	+0,50	RDB5650	8190DB	55,97	+0,01	RDB5600
8170DC	53,97	+0,02	RSB5400	8024D100	56,94	+1,00	RDB5700	8190DC	55,98	+0,02	RDB5600
8170D200	55,95	+2,00	RSB5600	8024D150	57,44	+1,50	RDB5750	8190DD	55,99	+0,03	RDB5600
8170D400	57,95	+4,00	RSB5800								

	set includes		
Clip Part No.	CW15	CW16	CW16
Pin Part No.	WP032	WP036	WP036
Rings	included	included	included
Price-Code	2	2	2/1
Stroke	54.5	50.6	50.6
Comp. Height (mm)	28	30.40	30.60

	extra parts		
Top End Gasket Kit	D2007-EST	-	-
Wössner Connecting rods	P2009	-	-
Needle bearing	N1047	-	-
Main bearing	2 x MB6322C4	-	-

## Honda® - 2 stroke



Model	NSR125 / CRM125 R	CR250 / MR250 / MT250	CR250 / MR250 / MT250
Years	91-03	73-74	75-77
Displ. (cc)	124	248	248

Piston Kit Part No.	Piston size (mm)	Over size (mm)	Ring Set Part No.	Piston Kit Part No.	Piston size (mm)	Over size (mm)	Ring Set Part No.	Piston Kit Part No.	Piston size (mm)	Over size (mm)	Ring Set Part No.
8019DA	53,94	Std.	RDB5400	8152DA	69,94	Std.	RDB7000	8153DA	69,94	Std.	RDB7000
8019DB	53,95	+0,01	RDB5400	8152D050	70,44	+0,50	RDB7050	8153D050	70,44	+0,50	RDB7050
8019DC	53,96	+0,02	RDB5400	8152D100	70,94	+1,00	RDB7100	8153D100	70,94	+1,00	RDB7100
8019D050	54,44	+0,50	RDB5450	8152D150	71,44	+1,50	RDB7150	8153D150	71,44	+1,50	RDB7150
8019D100	54,94	+1,00	RDB5500	8152D200	71,94	+2,00	RDB7200	8153D200	71,94	+2,00	RDB7200

	set includes		
Clip Part No.	CW16	CW18	CW18
Pin Part No.	WP036	WP033	WP033
Rings	included	included	included
Price-Code	2	3/1	3/1
Stroke	54.5	64.4	64.4
Comp. Height (mm)	30	32	32

	extra parts		
Top End Gasket Kit	D2045-EST	-	-
Wössner Connecting rods	-	-	-
Needle bearing	-	N1021	N1021
Main bearing	-	-	-

## Honda® - 2 stroke



Model	CR250R	CR250R	CR250R / ATAC250
Years	78-80	81-83	84-85
Displ. (cc)	248	246	246

Piston Kit Part No.	Piston size (mm)	Over size (mm)	Ring Set Part No.	Piston Kit Part No.	Piston size (mm)	Over size (mm)	Ring Set Part No.	Piston Kit Part No.	Piston size (mm)	Over size (mm)	Ring Set Part No.
8154DA	69,94	Std.	RDB7000	8155DA	65,94	Std.	RDB6600	8156DA	65,94	Std.	RDB6600
8154D050	70,44	+0,50	RDB7050	8155D050	66,44	+0,50	RDB6650	8156D025	66,19	+0,25	RDB6625
8154D100	70,94	+1,00	RDB7100	8155D100	66,94	+1,00	RDB6700	8156D050	66,44	+0,50	RDB6650
8154D150	71,44	+1,50	RDB7150	8155D150	67,44	+1,50	RDB6750	8156D075	66,69	+0,75	RDB6675
8154D200	71,94	+2,00	RDB7200	8155D200	67,94	+2,00	RDB6800	8156D100	66,94	+1,00	RDB6700
								8156D125	67,19	+1,25	RDB6725
								8156D150	67,44	+1,50	RDB6750
								8156D200	67,94	+2,00	RDB6800
								8156D250	68,44	+2,50	RDB6850
								8156D300	68,94	+3,00	RDB6900
								8156D350	69,44	+3,50	RDB6950

	set includes		
Clip Part No.	CW18	CW18	CW18
Pin Part No.	WP033	WP033	WP033
Rings	included	included	included
Price-Code	3/1	3/1	3/1
Stroke	64.4	72	72
Comp. Height (mm)	32.50	41.20	38

	extra parts		
Top End Gasket Kit	-	-	-
Wössner Connecting rods	P2012	P2012	P2021
Needle bearing	N1021	N1021	N1021
Main bearing	2 x MB6328C3	2 x MB6328C3	2 x MB6328C3



## Honda® - 2 stroke



Model	CR250R	CR250R	CR250R Single Ring
Years	86-96	97-01	97-01
Displ. (cc)	249	249	249

Piston Kit Part No.	Piston size (mm)	Over size (mm)	Ring Set Part No.	Piston Kit Part No.	Piston size (mm)	Over size (mm)	Ring Set Part No.	Piston Kit Part No.	Piston size (mm)	Over size (mm)	Ring Set Part No.
8021DA	66,34	Std.	RDB6640	8001DA	66,34	Std.	RDB6640	8161DA	66,34	Std.	RSB6640
8021DB	66,35	+0,01	RDB6640	8001DB	66,35	+0,01	RDB6640	8161DB	66,35	+0,01	RSB6640
8021DC	66,36	+0,02	RDB6640	8001DC	66,36	+0,02	RDB6640	8161DC	66,36	+0,02	RSB6640
8021D060	66,94	+0,60	RDB6700	8001D060	66,94	+0,60	RDB6700	8161D060	66,94	+0,60	RSB6700
8021D110	67,44	+1,10	RDB6750	8001D110	67,44	+1,10	RDB6750	8161D110	67,44	+1,10	RSB6750
8021D160	67,94	+1,60	RDB6800	8001D160	67,94	+1,60	RDB6800	8161D160	67,94	+1,60	RSB6800
8021D210	68,44	+2,10	RDB6850	8001D210	68,44	+2,10	RDB6850	8161D210	68,44	+2,10	RSB6850

	set includes		
Clip Part No.	CW18	CW18	CW18
Pin Part No.	WP033	WP033	WP033
Rings	included	included	included
Price-Code	3	3	3/1
Stroke	72	72	72
Comp. Height (mm)	38	38	38

	extra parts		
Top End Gasket Kit	D2008-EST	D2008-EST	D2008-EST
Wössner Connecting rods	P2021	P2021	P2021
Needle bearing	N1021	N1021	N1021
Main bearing	2 x MB6328C3	2 x MB6328C3 '97-99 2 x MB6328C4 '00-07	2 x MB6328C3 '97-99 2 x MB6328C4 '00-07

## Honda® - 2 stroke



<b>Model</b>	CR250R	CR250R Single Ring	CR250R
<b>Years</b>	02-04	02-04	05-07
<b>Displ. (cc)</b>	249	249	249

Piston Kit Part No.	Piston size (mm)	Over size (mm)	Ring Set Part No.	Piston Kit Part No.	Piston size (mm)	Over size (mm)	Ring Set Part No.	Piston Kit Part No.	Piston size (mm)	Over size (mm)	Ring Set Part No.
8066DA	66,34	Std.	RDB6640	8164DA	66,34	Std.	RSB6640	8171DA	66,34	Std.	RDB6640
8066DB	66,35	+0,01	RDB6640	8164DB	66,35	+0,01	RSB6640	8171DB	66,35	+0,01	RDB6640
8066DC	66,36	+0,02	RDB6640	8164DC	66,36	+0,02	RSB6640	8171DC	66,36	+0,02	RDB6640
8066D060	66,94	+0,60	RDB6700	8164DD	66,37	+0,03	RSB6640	8171D060	66,94	+0,60	RDB6700
8066D110	67,44	+1,10	RDB6750					8171D110	67,44	+1,10	RDB6750
8066D160	67,94	+1,60	RDB6800					8171D210	68,44	+2,10	RDB6850
8066D210	68,44	+2,10	RDB6850								

set includes			
<b>Clip Part No.</b>	CW18	CW18	CW18
<b>Pin Part No.</b>	WP033	WP033	WP033
<b>Rings</b>	included	included	included
<b>Price-Code</b>	3	3/1	3
<b>Stroke</b>	72	72	72
<b>Comp. Height (mm)</b>	38	38	38

extra parts			
<b>Top End Gasket Kit</b>	D2009-EST	D2009-EST	D2009-EST
<b>Wössner Connecting rods</b>	P2020	P2020	P2020
<b>Needle bearing</b>	N1021	N1021	N1021
<b>Main bearing</b>	2 x MB6328C4	2 x MB6328C4	2 x MB6328C4

## Honda® - 2 stroke



Model	CR250R - Single Ring	CRM250	CR500
Years	05-07	all	84-89
Displ. (cc)	249	249	500

Piston Kit Part No.	Piston size (mm)	Over size (mm)	Ring Set Part No.	Piston Kit Part No.	Piston size (mm)	Over size (mm)	Ring Set Part No.	Piston Kit Part No.	Piston size (mm)	Over size (mm)	Ring Set Part No.
8172DA	66,34	Std.	RSB6640	8071DA	65,93	Std.	RDB6600	8229DA	88,92	Std.	RSC8900
8172DB	66,35	+0,01	RSB6640	8071DB	65,94	+0,01	RDB6600	8229D050	89,42	+0,50	RSC8950
8172DC	66,36	+0,02	RSB6640	8071DC	65,95	+0,02	RDB6600	8229D100	89,92	+1,00	RSC9000
8172D210	68,44	+2,10	RSB6850	8071D040	66,33	+0,40	RDB6640	8229D150	90,42	+1,50	RSC9050
				8071D050	66,43	+0,50	RDB6650	8229D200	90,92	+2,00	RSC9100
				8071D100	66,93	+1,00	RDB6700				
				8071D150	67,43	+1,50	RDB6750				
				8071D200	67,93	+2,00	RDB6800				

	set includes		
Clip Part No.	CW18	CW19	CW20
Pin Part No.	WP033	WP044	WP086
Rings	included	included	included
Price-Code	3/1	3	6/1
Stroke	72	72	79
Comp. Height (mm)	38	33	40

	extra parts		
Top End Gasket Kit	D2009-EST	D2046-EST	-
Wössner Connecting rods	P2020	-	P2044 `87-01
Needle bearing	N1021	-	N1030
Main bearing	2 x MB6328C4	-	2 x MB6328C4

## Honda® - 4 stroke



Verdichtungen beziehen sich auf Standardmaße „-DA“

Compression ratio refer to standard sizes “-DA”

Model	CRF150R Pro Series	CRF150	CRF150 Pro Series
Years	07-09	12-14	12-14
Displ. (cc)	149 (D400 = 170)	149,7	149,7

Piston Kit Part No.	Piston size (mm)	Over size (mm)	Ring Set Part No.	Piston Kit Part No.	Piston size (mm)	Over size (mm)	Ring Set Part No.	Piston Kit Part No.	Piston size (mm)	Over size (mm)	Ring Set Part No.
8662DA	65,95	Std.	660XKS	8861DA	65,95	Std.	660XKS	8862DA	65,95	Std.	660XKS
8662DB	65,96	+0,01	660XKS	8861DB	65,96	+0,01	660XKS	8862DB	65,96	+0,01	660XKS
8662DC	65,97	+0,02	660XKS	8861DC	65,97	+0,02	660XKS	8862DC	65,97	+0,02	660XKS
8662D200	67,95	+2,00	680XKS								
8662D400	69,95	+4,00	700XDS								

	set includes		
Clip Part No.	CW14	CW14	CW14
Pin Part No.	WP058	WP058	WP058
Rings	included	included	included
Price-Code	4	4	4
Stroke	43.7	43.8	43.8
Wössner/ OEM Comp. ratio	DA-D200 = 12.5:1 / D400 = 13.5:1 11.7:1	11.7:1 11.7:1	12.2 :1 11.7:1
Dome Volume (CC)	-1.8 cm <sup>3</sup>	-1.4 cm <sup>3</sup>	-0.8 cm <sup>3</sup>
Comp. Height (mm)	20.60	20.60	20.60

	extra parts		
Top End Gasket Kit	D4001-EST	-	-
Wössner Connecting rods	P4024	P4024	P4024
Needle bearing	-	-	-
Main bearing	-	-	-

## Honda® - 4 stroke



Verdichtungen beziehen sich auf Standardmaße „-DA“  
 Compression ratio refer to standard sizes “-DA”

Model	CRF 230F	CRF250 / CRF250X	CRF250 / CRF250X Pro Series
Years	03-09 & 12-14	04-05	04-09
Displ. (cc)	230	249	249

Piston Kit Part No.	Piston size (mm)	Over size (mm)	Ring Set Part No.	Piston Kit Part No.	Piston size (mm)	Over size (mm)	Ring Set Part No.	Piston Kit Part No.	Piston size (mm)	Over size (mm)	Ring Set Part No.
8774DA	65,46	Std.	655XKS	8587DA	77,95	Std.	780XAS	8590DA	77,96	Std.	780XAS
8774D050	65,96	+0,50	660XKS	8587DB	77,96	+0,01	780XAS	8590DB	77,97	+0,01	780XAS
8774D100	66,46	+1,00	665XKS	8587DC	77,97	+0,02	780XAS	8590DC	77,98	+0,02	780XAS
8774D150	66,96	+1,50	670XKS	8587D400	81,95	+4,00	820XSY				
8774D200	67,46	+2,00	675XKS								

	set includes		
Clip Part No.	CW15	CW16	CW16
Pin Part No.	WP011	WP059	WP059
Rings	included	included	included
Price-Code	4	5	5
Stroke	66.2	52.2	52.2
Wössner/ OEM Comp. ratio	11:1 9:1	12.9:1 12.9:1	13.9:1 12.9:1
Dome Volume (CC)	+3.1 cm <sup>3</sup>	-1 cm <sup>3</sup>	+0 cm <sup>3</sup>
Comp. Height (mm)	21.2	18.90	19

	extra parts		
Top End Gasket Kit	D4002-EST	D4004-EST	D4004-EST
Wössner Connecting rods	P4053 `03-14	P4001 `04-14	P4001 `10-14
Needle bearing	-	-	-
Main bearing	-	2 x MB6328C3	2 x MB6328C3

## Honda® - 4 stroke

Verdichtungen beziehen sich auf Standardmaße „-DA“  
 Compression ratio refer to standard sizes “-DA”



Model	CRF250 / CRF250X	CRF250 Pro Series	CRF450R
Years	06-09	10-14	02-03
Displ. (cc)	249	249	449

Piston Kit Part No.	Piston size (mm)	Over size (mm)	Ring Set Part No.	Piston Kit Part No.	Piston size (mm)	Over size (mm)	Ring Set Part No.	Piston Kit Part No.	Piston size (mm)	Over size (mm)	Ring Set Part No.
8656DA	77,96	Std.	780XAS	8775DA	76,76	Std.	768XAS	8546DA	95,96	Std.	960ADS-2
8656DB	77,97	+0,01	780XAS	8775DB	76,77	+0,01	768XAS	8546DB	95,97	+0,01	960ADS-2
8656DC	77,98	+0,02	780XAS	8775DC	76,78	+0,02	768XAS	8546DC	95,98	+0,02	960ADS-2
8656D200	79,96	+2,00	800XDS	8775D220	78,96	+2,20	790XAS				
8656D400	81,96	+4,00	820XDS								

	set includes		
Clip Part No.	CW16	CW16	CW19
Pin Part No.	WP059	WP070	WP037
Rings	included	included	included
Price-Code	5	5	7
Stroke	52.2	53.8	62.1
Wössner/ OEM Comp. ratio	13.5:1 12.9:1	14.2:1 13.2:1	12:1 11.5:1
Dome Volume (CC)	-0.9 cm <sup>3</sup>	+0.1 cm <sup>3</sup>	-2.2 cm <sup>3</sup>
Comp. Height (mm)	19	19	24

	extra parts		
Top End Gasket Kit	D4004-EST	D4005-EST	D4006-EST
Wössner Connecting rods	P4001 `04-14	P4001 `04-14	P4026
Needle bearing	-	-	-
Main bearing	2 x MB6328C3	-	2 x MB6328C3

## Honda® - 4 stroke



Verdichtungen beziehen sich auf Standardmaße „-DA“

Compression ratio refer to standard sizes “-DA”

Model	CRF450R Big Bore Pro Series	CRF450R Big Bore	CRF450R
Years	02-08	'02-08	'04
Displ. (cc)	496	449	449

Piston Kit Part No.	Piston size (mm)	Over size (mm)	Ring Set Part No.	Piston Kit Part No.	Piston size (mm)	Over size (mm)	Ring Set Part No.	Piston Kit Part No.	Piston size (mm)	Over size (mm)	Ring Set Part No.
8546D400A	99,96	Std.	1000ADS-2	8584D400A	99,96	+4,00	1000ADS-2	8607DA	95,96	Std.	960ADS-2
8546D400B	99,97	+0,01	1000ADS-2	8584D400B	99,97	+4,01	1000ADS-2	8607DB	95,97	+0,01	960ADS-2
								8607DC	95,98	+0,02	960ADS-2

set includes			
Clip Part No.	CW19	CW19	CW19
Pin Part No.	WP037	WP037	WP037
Rings	included	included	included
Price-Code	7	7/1	7/1
Stroke	62.1	62.1	62.1
Wössner/ OEM Comp. ratio	12:1 11.5:1	11.8:1 11.5:1	11.9:1 11.9:1
Dome Volume (CC)	-2.2 cm <sup>3</sup>	-6.5 cm <sup>3</sup>	-1.7 cm <sup>3</sup>
Comp. Height (mm)	24	24	24

extra parts			
Top End Gasket Kit	-	-	D4006-EST
Wössner Connecting rods	P4026	P4026	P4026
Needle bearing	-	-	-
Main bearing	2 x MB6328C3	2 x MB6328C3	2 x MB6328C3

## Honda® - 4 stroke



Verdichtungen beziehen sich auf Standardmaße „-DA“  
 Compression ratio refer to standard sizes “-DA”

Model	CRF450R / CRF450X	CRF450R - Pro Series 2. Ring	CRF450R
Years	05-08 / 05-13	02-08	09-12
Displ. (cc)	449	449	449

Piston Kit Part No.	Piston size (mm)	Over size (mm)	Ring Set Part No.	Piston Kit Part No.	Piston size (mm)	Over size (mm)	Ring Set Part No.	Piston Kit Part No.	Piston size (mm)	Over size (mm)	Ring Set Part No.
8608DA	95,96	Std.	960ADS-2	8668DA	95,96	Std.	960ADS-2	8739DA	95,96	Std.	960ADS-2
8608DB	95,97	+0,01	960ADS-2	8668DB	95,97	+0,01	960ADS-2	8739DB	95,97	+0,01	960ADS-2
8608DC	95,98	+0,02	960ADS-2	8668DC	95,98	+0,02	960ADS-2	8739DC	95,98	+0,02	960ADS-2

	set includes		
Clip Part No.	CW19	CW19	CW19
Pin Part No.	WP071	WP037	WP037
Rings	included	included	included
Price-Code	7	7	7
Stroke	62.1	62.1	62.1
Wössner/ OEM Comp. ratio	12:1 12:1	13.5:1	12:1 12:1
Dome Volume (CC)	-1.4 cm <sup>3</sup>	+3.5 cm <sup>3</sup>	-4.6 cm <sup>3</sup>
Comp. Height (mm)	24	24	20.70

	extra parts		
Top End Gasket Kit	D4006-EST `02-06 D4007-EST `07-08	D4006-EST `02-06 D4007-EST `07-08	D4008-EST
Wössner Connecting rods	P4026 P4023 `05-13	P4026	P4027 `09-14
Needle bearing	-	-	-
Main bearing	2 x MB6328C3	2 x MB6328C3	2 x MB6328C3



## Honda® - 4 stroke



Verdichtungen beziehen sich auf Standardmaße „-DA“  
 Compression ratio refer to standard sizes “-DA”

Model	CRF450R - Pro Series 2. Ring	CRF450R 2. Ring <b>New!</b>	CRF450R Pro Series 2. Ring <b>New!</b>
Years	09-12	13-14	13-14
Displ. (cc)	449	449,5	449,5

Piston Kit Part No.	Piston size (mm)	Over size (mm)	Ring Set Part No.	Piston Kit Part No.	Piston size (mm)	Over size (mm)	Ring Set Part No.	Piston Kit Part No.	Piston size (mm)	Over size (mm)	Ring Set Part No.
8768DA	95,96	Std.	960ADS-2	8880DA	95,96	Std.	960ADS-2	8881DA	95,96	Std.	960ADS-2
8768DB	95,97	+0,01	960ADS-2	8880DB	95,97	+0,01	960ADS-2	8881DB	95,97	+0,01	960ADS-2
8768DC	95,98	+0,02	960ADS-2	8880DC	95,98	+0,02	960ADS-2	8881DC	95,98	+0,02	960ADS-2

	set includes		
Clip Part No.	CW19	CW19	CW19
Pin Part No.	WP028	WP028	WP028
Rings	included	included	included
Price-Code	7	7	7
Stroke	62.1	62.1	62.1
Wössner/ OEM Comp. ratio	13.4:1 12.0:1	12.5:1 12.5:1	13.8:1 12.5:1
Dome Volume (CC)	-0.03 cm <sup>3</sup>	-2.6 cm <sup>3</sup>	+1.5 cm <sup>3</sup>
Comp. Height (mm)	20.70	20.70	20.70

	extra parts		
Top End Gasket Kit	D4008-EST	D4008-EST	D4008-EST
Wössner Connecting rods	P4027 `09-14	P4027 `09-14	P4027 `09-14
Needle bearing	-	-	-
Main bearing	2 x MB6328C3	2 x MB6328C3	2 x MB6328C3

## Honda® - 4 stroke



Verdichtungen beziehen sich auf Standardmaße „-DA“  
 Compression ratio refer to standard sizes “-DA”

Model	XR185 / XR200 ATC185 / ATC200S	XL250S / XR250	XR250 / XL250R
Years	86-02 / 80-83 / 81-86 / 81-86	79-82 / thru 83	84-87
Displ. (cc)	195	249	249

Piston Kit Part No.	Piston size (mm)	Over size (mm)	Ring Set Part No.	Piston Kit Part No.	Piston size (mm)	Over size (mm)	Ring Set Part No.	Piston Kit Part No.	Piston size (mm)	Over size (mm)	Ring Set Part No.
8813DA	65,46	Std.	655XKS	8791DA	73,94	Std.	740XDS	8792DA	74,94	Std.	750XDS
8813D050	65,96	+0,50	660XKS	8791D050	74,44	+0,50	745XDS	8792D050	75,44	+0,50	755XDS
8813D100	66,46	+1,00	665XKS	8791D100	74,94	+1,00	750XDS	8792D100	75,94	+1,00	760XDS
8813D150	66,96	+1,50	670XKS	8791D150	75,44	+1,50	755XDS				
8813D200	67,46	+2,00	675XKS	8791D200	75,94	+2,00	760XDS				

	set includes		
Clip Part No.	CW15	CW19	CW17
Pin Part No.	WP011	WP028	WP090
Rings	included	included	included
Price-Code	5	5	5
Stroke	57.8	57.8	56.5
Wössner/ OEM Comp. ratio	10:1 10:1	10:1 9.1:1	10.2:1 10.2:1
Dome Volume (CC)	+1.4 cm <sup>3</sup>	+9.3 cm <sup>3</sup>	+6.4 cm <sup>3</sup>
Comp. Height (mm)	25.5	24.7	25.4

	extra parts		
Top End Gasket Kit	-	-	-
Wössner Connecting rods	-	-	P4025 `86-04
Needle bearing	-	-	-
Main bearing	-	-	-

## Honda® - 4 stroke



Verdichtungen beziehen sich auf Standardmaße „-DA“  
 Compression ratio refer to standard sizes “-DA”

Model	XR250 / XL250	XR350R will not fit for XL models	XR400 / XLS400
Years	86-04 / 91-96	83-85	81-82 / 81-82
Displ. (cc)	249	339	398

Piston Kit Part No.	Piston size (mm)	Over size (mm)	Ring Set Part No.	Piston Kit Part No.	Piston size (mm)	Over size (mm)	Ring Set Part No.	Piston Kit Part No.	Piston size (mm)	Over size (mm)	Ring Set Part No.
8793DA	72,94	Std.	730XDS	8641DA	83,94	Std.	840XSY	8642DA	88,94	Std.	890XSY
8793D050	73,44	+0,50	735XDS	8641D050	84,44	+0,50	845XSY	8642D050	89,44	+0,50	895XSY
8793D100	73,94	+1,00	740XDS	8641D100	84,94	+1,00	850XSY	8642D100	89,94	+1,00	900XSY
8793D250	75,44	+2,50	755XDS					8642D150	90,44	+1,50	905XSY
8793D400	76,94	+4,00	770XDS					8642D200	90,94	+2,00	910XSY
8793D500	77,94	+5,00	780XDS								

set includes			
Clip Part No.	CW17	CW21	CW21
Pin Part No.	WP090	WP034	WP034
Rings	included	included	included
Price-Code	5	7/1	7/1
Stroke	59.5	61.3	64
Wössner/ OEM Comp. ratio	10.5:1 9.3:1	9.5:1 9.5:1	9:1 8.6:1
Dome Volume (CC)	+6 cm <sup>3</sup>	+5 cm <sup>3</sup>	0 cm <sup>3</sup>
Comp. Height (mm)	25	26.50	29.70

extra parts			
Top End Gasket Kit	D4003-EST	-	D4039-EST
Wössner Connecting rods	P4025 `86-04	-	-
Needle bearing	-	-	-
Main bearing	-	-	-

## Honda® - 4 stroke



Verdichtungen beziehen sich auf Standardmaße „-DA“

Compression ratio refer to standard sizes “-DA”

Model	XR400R	XLR500 / XLS500 / XR500R	XR600R / XR600
Years	96-04	79-84 / 79-84 / 79-82	85-01
Displ. (cc)	397	497	591-654

Piston Kit Part No.	Piston size (mm)	Over size (mm)	Ring Set Part No.	Piston Kit Part No.	Piston size (mm)	Over size (mm)	Ring Set Part No.	Piston Kit Part No.	Piston size (mm)	Over size (mm)	Ring Set Part No.
8604DA	84,94	Std.	850XSY	8642DA	88,94	Std.	890XSY	8574DA	96,94	Std.	970XSY
8604D050	85,44	+0,50	855XSY	8642D050	89,44	+0,50	895XSY	8574DB	96,95	+0,01	970XSY
8604D100	85,94	+1,00	860XSY	8642D100	89,94	+1,00	900XSY	8574DC	96,96	+0,02	970XSY
8604D150	86,44	+1,50	865XSY	8642D150	90,44	+1,50	905XSY	8574D050	97,44	+0,50	975XSY
8604D200	86,94	+2,00	870XSY	8642D200	90,94	+2,00	910XSY	DA - D050 WP057			
8604D300	87,94	+3,00	880XSY					8574D100	97,94	+1,00	980XSY
8604D400	88,94	+4,00	890XSY					8574D200	98,94	+2,00	990XSY
								8574D300	99,94	+3,00	1000XSY
								8574D400	100,94	+4,00	1010XSY
								8574D500	101,94	+5,00	1020XSU
								D100 - D500 WP023			

	set includes		
Clip Part No.	CW20	CW21	CW24
Pin Part No.	WP052	WP034	WP057 DA - D050 WP023 D100 - D500
Rings	included	included	included
Price-Code	7/1	7/1	7/1
Stroke	70	80	80
Wössner/ OEM Comp. ratio	11:1 9.3:1	9:1 8.6:1	9.3:1 9.0:1
Dome Volume (CC)	+3.2 cm <sup>3</sup>	0 cm <sup>3</sup>	-4.8 cm <sup>3</sup>
Comp. Height (mm)	26.20	29.7	29.70

	extra parts		
Top End Gasket Kit	-	D4039-EST	-
Wössner Connecting rods	P4033 '96-04	-	P4028
Needle bearing	-	-	-
Main bearing	-	2 x MB6307C3	-

## Honda® - 4 stroke



Verdichtungen beziehen sich auf Standardmaße „-DA“  
 Compression ratio refer to standard sizes “-DA”

<b>Model</b>	XL600R	NX650 Dominator / XR650C / XR650L
<b>Years</b>	83-87	88-04 / 93-14 / 96-14
<b>Displ. (cc)</b>	589	644

Piston Kit Part No.	Piston size (mm)	Over size (mm)	Ring Set Part No.	Piston Kit Part No.	Piston size (mm)	Over size (mm)	Ring Set Part No.
8822DA	99,94	Std.	1000XSY	8564DA	99,93	Std.	1000XSY
8822D050	100,44	0,50	1005XSY	8564DB	99,94	+0,01	1000XSY
8822D100	100,94	1,00	1010XSY	8564DC	99,95	+0,02	1000XSY
				8564D100	100,93	+1,00	1010XSY
				8564D200	101,93	+2,00	1020XSK

set includes		
<b>Clip Part No.</b>	CW24	CW24
<b>Pin Part No.</b>	WP057	WP057
<b>Rings</b>	included	included
<b>Price-Code</b>	7/1	7/1
<b>Stroke</b>	75	82
<b>Wössner/ OEM Comp. ratio</b>	10.2:1 9:1	8.3:1 8.3:1
<b>Dome Volume (CC)</b>	-5.9 cm <sup>3</sup>	+0 cm <sup>3</sup>
<b>Comp. Height (mm)</b>	32.8	29

extra parts		
<b>Top End Gasket Kit</b>	-	D4052-EST `88-89
<b>Wössner Connecting rods</b>	P4028	-
<b>Needle bearing</b>	-	-
<b>Main bearing</b>	-	2 x MB6308C3

## Honda® - 4 stroke



Verdichtungen beziehen sich auf Standardmaße „-DA“

Compression ratio refer to standard sizes “-DA”

<b>Model</b>	<b>XR650R</b> Will not fit for XR650L	<b>XR650R</b> Will not fit for XR650L
<b>Years</b>	00-07	00-07
<b>Displ. (cc)</b>	644	644

Piston Kit Part No.	Piston size (mm)	Over size (mm)	Ring Set Part No.	Piston Kit Part No.	Piston size (mm)	Over size (mm)	Ring Set Part No.
8575DA	99,94	Std.	1000XSY	8718DA	99,94	Std.	1000XSY
8575DB	99,95	+0,01	1000XSY	8718DB	99,95	+0,01	1000XSY
8575DC	99,96	+0,02	1000XSY	8718DC	99,96	+0,02	1000XSY
8575D100	100,94	+1,00	1010XSY	8718D100	100,94	+1,00	1010XSY
8575D200	101,94	+2,00	1020XSU	8718D200	101,94	+2,00	1020XSK

set includes		
<b>Clip Part No.</b>	CW23	CW23
<b>Pin Part No.</b>	WP024	WP024
<b>Rings</b>	included	included
<b>Price-Code</b>	7/1	7/1
<b>Stroke</b>	82,6	82,6
<b>Wössner/ OEM Comp. ratio</b>	10:1 10:1	11:1 10:1
<b>Dome Volume (CC)</b>	-3.6 cm <sup>3</sup>	-1.2 cm <sup>3</sup>
<b>Comp. Height (mm)</b>	29	29

extra parts		
<b>Top End Gasket Kit</b>	-	-
<b>Wössner Connecting rods</b>	P4056	P4056
<b>Needle bearing</b>	-	-
<b>Main bearing</b>	2 x MB6308C3	2 x MB6308C3

## Husaberg® - 2 stroke



Model	TE125 Single Ring	TE250	TE300
Years	12-14	11-14	11-14
Displ. (cc)	125	249	297

Piston Kit Part No.	Piston size (mm)	Over size (mm)	Ring Set Part No.	Piston Kit Part No.	Piston size (mm)	Over size (mm)	Ring Set Part No.	Piston Kit Part No.	Piston size (mm)	Over size (mm)	Ring Set Part No.
8220DA	53,95	Std.	RSV5400	8272DA	66,34	Std.	RDB6640	8273DA	71,94	Std.	RDB7200
8220DB	53,96	+0,01	RSV5400	8272DB	66,35	+0,01	RDB6640	8273DB	71,95	+0,01	RDB7200
8220DC	53,97	+0,02	RSV5400	8272DC	66,36	+0,02	RDB6640	8273DC	71,96	+0,02	RDB7200
8220D200	55,95	+2,00	RSB5600								
8220D400	57,95	+4,00	RSB5800								

	set includes		
Clip Part No.	CW15	CW18	CW18
Pin Part No.	WP032	WP033	WP033
Rings	included	included	included
Price-Code	2	3	6
Stroke	54.5	72	72
Comp. Height (mm)	29.5	38	38

	extra parts		
Top End Gasket Kit	D2043-EST	D2025-EST `11-12	D2025-EST `11-12
Wössner Connecting rods	P2012	P2023	P2023 `11-14
Needle bearing	N1010	N1020	N1020
Main bearing	-	-	-

## Husaberg® - 4 stroke



Verdichtungen beziehen sich auf Standardmaße „-DA“  
 Compression ratio refer to standard sizes “-DA”

**New!**

Model	FE250	FC350 / FE350	FE390 Fuel injection
Years	13	89-96	10-13
Displ. (cc)	249	350	398

Piston Kit Part No.	Piston size (mm)	Over size (mm)	Ring Set Part No.	Piston Kit Part No.	Piston size (mm)	Over size (mm)	Ring Set Part No.	Piston Kit Part No.	Piston size (mm)	Over size (mm)	Ring Set Part No.
8690DA	75,96	Std.	760XAS	8517DA	85,95	Std.	860XSY	8824DA	94,95	Std.	950ADS-2
8690DB	75,97	+0,01	760XAS	8517DB	85,96	+0,01	860XSY	8824DB	94,96	+0,01	950ADS-2
								8824DC	94,97	+0,02	950ADS-2

	set includes		
Clip Part No.	CW16	CW18	CW19
Pin Part No.	WP059	WP031	WP071
Rings	included	included	included
Price-Code	5/1	7/1	7/1
Stroke	54.8	60.1	55.5
Wössner/ OEM Comp. ratio	13.2:1	-	11.1:1
Dome Volume (CC)	+2.3 cm <sup>3</sup>	+1.5 cm <sup>3</sup>	-1.1 cm <sup>3</sup>
Comp. Height (mm)	19.5	23	23.2

	extra parts		
Top End Gasket Kit	-	-	-
Wössner Connecting rods	P4003	-	-
Needle bearing	-	-	-
Main bearing	-	-	-



## Husaberg® - 4 stroke



Verdichtungen beziehen sich auf Standardmaße „-DA“

Compression ratio refer to standard sizes “-DA”

Model	FC400 / FE400	FC450 / FE450	FC450 / FE450/ FX 450
Years	96-05 / 96-05	04-08	09-12 / 09-12 / 10-12
Displ. (cc)	397	449	449

Piston Kit Part No.	Piston size (mm)	Over size (mm)	Ring Set Part No.	Piston Kit Part No.	Piston size (mm)	Over size (mm)	Ring Set Part No.	Piston Kit Part No.	Piston size (mm)	Over size (mm)	Ring Set Part No.
8519DA	91,95	Std.	920XS	8593DA	99,95	Std.	1000XS	8707DA	94,95	Std.	950ADS-2
8519DB	91,96	+0,01	920XS	8593DB	99,96	+0,01	1000XS	8707DB	94,96	+0,01	950ADS-2
8519DC	91,97	+0,02	920XS	8593DC	99,97	+0,02	1000XS	8707DC	94,97	+0,02	950ADS-2
				8593D050	100,45	+0,50	1005XS				

	set includes		
Clip Part No.	CW18	CW20	CW19
Pin Part No.	WP031	WP038	WP037
Rings	included	included	included
Price-Code	7/1	7/1	7
Stroke	59.8	57.2	63,4
Wössner/ OEM Comp. ratio	-	- 13:1	11.9:1 11.9:1
Dome Volume (CC)	-3.3 cm <sup>3</sup>	+9.0 cm <sup>3</sup>	-1.9 cm <sup>3</sup>
Comp. Height (mm)	22.6	24.30	22.80

	extra parts		
Top End Gasket Kit	-	-	-
Wössner Connecting rods	-	-	P4016
Needle bearing	-	-	-
Main bearing	-	-	2 x MBNJ206C3

## Husaberg® - 4 stroke



Verdichtungen beziehen sich auf Standardmaße „-DA“

Compression ratio refer to standard sizes “-DA”

**New!**

Model	FE450	FC470 / FX470	FC501 / FE501
Years	2014	00-02 / 00-02	94-09 / 94-09
Displ. (cc)	449	472	501

Piston Kit Part No.	Piston size (mm)	Over size (mm)	Ring Set Part No.	Piston Kit Part No.	Piston size (mm)	Over size (mm)	Ring Set Part No.	Piston Kit Part No.	Piston size (mm)	Over size (mm)	Ring Set Part No.
8898DA	94,95	Std.	950ADS-2	8552DA	99,95	Std.	1000ADS-2	8537DA	94,95	Std.	950XSY
8898DB	94,96	+0,01	950ADS-2	8552DB	99,96	+0,01	1000ADS-2	8537DB	94,96	+0,01	950XSY
8898DC	94,97	+0,02	950ADS-2	8552DC	99,97	+0,02	1000ADS-2	8537DC	94,97	+0,02	950XSY

	set includes		
Clip Part No.	CW19	CW20	CW20
Pin Part No.	WP071	WP038	WP073
Rings	included	included	included
Price-Code	7	7/1	7/1
Stroke	63.4	60.1	70.1
Wössner/ OEM Comp. ratio	- 11.8:1	- 12.4:1	- 11.8:1
Dome Volume (CC)	-1.6 cm <sup>3</sup>	+5.6 cm <sup>3</sup>	-2.1 cm <sup>3</sup>
Comp. Height (mm)	22.80	22.60	23

	extra parts		
Top End Gasket Kit	-	-	-
Wössner Connecting rods	-	-	-
Needle bearing	-	-	-
Main bearing	-	-	-

## Husaberg® - 4 stroke



Verdichtungen beziehen sich auf Standardmaße „-DA“

Compression ratio refer to standard sizes “-DA”

Model	FC501 / FE501	FC550 / FE550	FC650 / FE650
Years	89-93	04-08	04-08 / 04-08
Displ. (cc)	501	549	644

Piston Kit Part No.	Piston size (mm)	Over size (mm)	Ring Set Part No.	Piston Kit Part No.	Piston size (mm)	Over size (mm)	Ring Set Part No.	Piston Kit Part No.	Piston size (mm)	Over size (mm)	Ring Set Part No.
8516DA	91,95	Std.	920XSY	8602DA	99,95	Std.	1000XSY	8551DA	99,95	Std.	1000XSY
8516DB	91,96	+0,01	920XSY	8602DB	99,96	+0,01	1000XSY	8551DB	99,96	+0,01	1000XSY
8516DC	91,97	+0,02	920XSY	8602DC	99,97	+0,02	1000XSY	8551DC	99,97	+0,02	1000XSY

	set includes		
Clip Part No.	CW20	CW20	CW20
Pin Part No.	WP038	WP038	WP038
Rings	included	included	included
Price-Code	7/1	7/1	7/1
Stroke	75.5	70	82
Wössner/ OEM Comp. ratio	-	12.5:1 11.8:1	- 11.8:1
Dome Volume (CC)	-3.5 cm <sup>3</sup>	-2.3 cm <sup>3</sup>	-2.1 cm <sup>3</sup>
Comp. Height (mm)	23	23.40	23

	extra parts		
Top End Gasket Kit	-	-	-
Wössner Connecting rods	-	-	-
Needle bearing	-	-	-
Main bearing	-	-	-

## Husaberg® - 4 stroke



Verdichtungen beziehen sich auf Standardmaße „-DA“

Compression ratio refer to standard sizes “-DA”

Model	FE570 Fuel injection	FC600 / FE600	FC601 / FE601
Years	09-12	89-00 / 89-00	94-98 / 94-98
Displ. (cc)	-	595	600

Piston Kit Part No.	Piston size (mm)	Over size (mm)	Ring Set Part No.	Piston Kit Part No.	Piston size (mm)	Over size (mm)	Ring Set Part No.	Piston Kit Part No.	Piston size (mm)	Over size (mm)	Ring Set Part No.
8737DA	99,95	Std.	1000XSY	8537DA	94,95	Std.	950XSY	8537DA	94,95	Std.	950XSY
8737DB	99,96	+0,01	1000XSY	8537DB	94,96	+0,01	950XSY	8537DB	94,96	+0,01	950XSY
8737DC	99,97	+0,02	1000XSY	8537DC	94,97	+0,02	950XSY	8537DC	94,97	+0,02	950XSY
								8537D300	97,95	+3,00	980XSY

	set includes		
Clip Part No.	CW20	CW20	CW20
Pin Part No.	WP038	WP073	WP073
Rings	included	included	included
Price-Code	7/1	7/1	7/1
Stroke	72	84	84
Wössner/ OEM Comp. ratio	11.8:1 11.8:1	- 11.8:1	- 11.8:1
Dome Volume (CC)	-10.5 cm <sup>3</sup>	-2.1 cm <sup>3</sup>	-2.1 cm <sup>3</sup>
Comp. Height (mm)	24.5	23	23

	extra parts		
Top End Gasket Kit	-	-	-
Wössner Connecting rods	-	-	-
Needle bearing	-	-	-
Main bearing	-	-	-

## Husaberg® - 4 stroke



Verdichtungen beziehen sich auf Standardmaße „-DA“  
 Compression ratio refer to standard sizes “-DA”

<b>Model</b>	FC601 / FE601	FE650 / FS650 / FX650
<b>Years</b>	94-98 / 94-98	00-09 / 00-09
<b>Displ. (cc)</b>	600	644

Piston Kit Part No.	Piston size (mm)	Over size (mm)	Ring Set Part No.	Piston Kit Part No.	Piston size (mm)	Over size (mm)	Ring Set Part No.
8551DA	99,95	Std.	1000XSY	8551DA	99,95	Std.	1000XSY
8551DB	99,96	+0,01	1000XSY	8551DB	99,96	+0,01	1000XSY
8551DC	99,97	+0,02	1000XSY	8551DC	99,97	+0,02	1000XSY

set includes		
<b>Clip Part No.</b>	CW20	CW20
<b>Pin Part No.</b>	WP038	WP038
<b>Rings</b>	included	included
<b>Price-Code</b>	7/1	7/1
<b>Stroke</b>	82	82
<b>Wössner/ OEM Comp. ratio</b>	- 11.8:1	- 11.8:1
<b>Dome Volume (CC)</b>	-2.1 cm <sup>3</sup>	-2.1 cm <sup>3</sup>
<b>Comp. Height (mm)</b>	23	23

extra parts		
<b>Top End Gasket Kit</b>	-	-
<b>Wössner Connecting rods</b>	-	-
<b>Needle bearing</b>	-	-
<b>Main bearing</b>	-	-

## Husqvarna® - 2 stroke



Model	CR125 / WR125	CR125 / WR125	WMX125 / WR125 with Dome
Years	76-83	84-87	88-91
Displ. (cc)	124	124	124

Piston Kit Part No.	Piston size (mm)	Over size (mm)	Ring Set Part No.	Piston Kit Part No.	Piston size (mm)	Over size (mm)	Ring Set Part No.	Piston Kit Part No.	Piston size (mm)	Over size (mm)	Ring Set Part No.
8035D075	55,69	+0,75	RSB5575	8173D050	55,44	+0,50	RSB5550	8060DA	55,95	Std.	RSB5600
8035D100	55,94	+1,00	RSB5600	8173D075	55,69	+0,75	RSB5575	8060DB	55,96	+0,01	RSB5600
8035D150	56,44	+1,50	RSB5650	8173D100	55,94	+1,00	RSB5600	8060D050	56,45	+0,50	RSB5650
				8173D150	56,44	+1,50	RSB5650	8060D100	56,95	+1,00	RSB5700

	set includes		
Clip Part No.	CW15	CW15	CW16
Pin Part No.	WP032	WP032	WP036
Rings	included	included	included
Price-Code	2/1	2/1	2/1
Stroke	-	-	-
Comp. Height (mm)	25	25	-

	extra parts		
Top End Gasket Kit	-	-	-
Wössner Connecting rods	-	-	-
Needle bearing	-	-	-
Main bearing	-	-	-

## Husqvarna® - 2 stroke



Model	CR125 / WR125	CR125 / WR125 / SM125 / SMS125 / WRE125	A8 125 / W8 125
Years	92-94	97-13	all
Displ. (cc)	124	125	125

Piston Kit Part No.	Piston size (mm)	Over size (mm)	Ring Set Part No.	Piston Kit Part No.	Piston size (mm)	Over size (mm)	Ring Set Part No.	Piston Kit Part No.	Piston size (mm)	Over size (mm)	Ring Set Part No.
8040DA	55,95	Std.	RSB5600	8089DA	53,95	Std.	RSB5400	8142DA	55,94	Std.	RDB5600
8040DB	55,96	+0,01	RSB5600	8089DB	53,96	+0,01	RSB5400	8142D025	56,19	+0,25	RDB5625
8040DC	55,97	+0,02	RSB5600	8089DC	53,97	+0,02	RSB5400	8142D100	56,94	+1,00	RDB5700
8040D050	56,45	+0,50	RSB5650	8089DD	53,98	+0,03	RSB5400				
8040D100	56,95	+1,00	RSB5700	8089D050	54,45	+0,50	RSB5450				
				8089D100	54,95	+1,00	RSB5500				

set includes			
Clip Part No.	CW16	CW15	CW16
Pin Part No.	WP036	WP032	WP036
Rings	included	included	included
Price-Code	2	2	2/1
Stroke	-	-	-
Comp. Height (mm)	25	28	29.9

extra parts			
Top End Gasket Kit	-	D2010-EST	-
Wössner Connecting rods	-	P2060	-
Needle bearing	N1014	N1047	-
Main bearing	-	2 x MB6322C4	-

## Husqvarna® - 2 stroke



**New!**

Model	TC125	CR150	CR240 / WR240
Years	2014	11-13	87-88
Displ. (cc)	125	144	240

Piston Kit Part No.	Piston size (mm)	Over size (mm)	Ring Set Part No.	Piston Kit Part No.	Piston size (mm)	Over size (mm)	Ring Set Part No.	Piston Kit Part No.	Piston size (mm)	Over size (mm)	Ring Set Part No.
8220DA	53,95	Std.	RSV5400	8283DA	57,94	Std.	RSB5800	8044D100	67,44	+1,00	RSB6750
8220DB	53,96	+0,01	RSV5400	8283DB	57,95	+0,01	RSB5800	8044D150	67,94	+1,50	RSB6800
8220DC	53,97	+0,02	RSV5400	8283DC	57,96	+0,02	RSB5800				
8220D200	55,95	+2,00	RSB5600								
8220D400	57,95	+4,00	RSB5600								

	set includes		
Clip Part No.	CW15	CW15	CW18
Pin Part No.	WP032	WP032	WP033
Rings	included	included	included
Price-Code	2	-	3/1
Stroke	54.5	54.5	-
Comp. Height (mm)	29.5	-	35

	extra parts		
Top End Gasket Kit	-	-	-
Wössner Connecting rods	-	P2060 `11	-
Needle bearing	N1010	N1047 `11	-
Main bearing	1 x MBNJ206 Left 1 x MB63052RS Right	2 x MB6322C4	-



## Husqvarna® - 2 stroke



<b>Model</b>	CR250 / WR250 / XR250	CR250 / WR250	CR250 / WR250
<b>Years</b>	74-84	85-86	87-91
<b>Displ. (cc)</b>	249	249	249

Piston Kit Part No.	Piston size (mm)	Over size (mm)	Ring Set Part No.	Piston Kit Part No.	Piston size (mm)	Over size (mm)	Ring Set Part No.	Piston Kit Part No.	Piston size (mm)	Over size (mm)	Ring Set Part No.
8004DA	69,44	Std.	RSB6950	8010DA	69,44	Std.	RDB6950	8199DA	69,94	Std.	RSB7000
8004D050	69,94	+0,50	RSB7000	8010D050	69,94	+0,50	RDB7000	8199DB	69,95	+0,01	RSB7000
8004D100	70,44	+1,00	RSB7050	8010D100	70,44	+1,00	RDB7050	8199DC	69,96	+0,02	RSB7000
8004D150	70,94	+1,50	RSB7100	8010D150	70,94	+1,50	RDB7100	8199DD	69,97	+0,03	RSB7000
8004D200	71,44	+2,00	RSB7150	8010D200	71,44	+2,00	RDB7150				

set includes			
<b>Clip Part No.</b>	CW18	CW18	CW18
<b>Pin Part No.</b>	WP033	WP033	WP033
<b>Rings</b>	included	included	included
<b>Price-Code</b>	3/1	3/1	3/1
<b>Stroke</b>	-	-	-
<b>Comp. Height (mm)</b>	32	32	30

extra parts			
<b>Top End Gasket Kit</b>	-	-	-
<b>Wössner Connecting rods</b>	-	-	-
<b>Needle bearing</b>	N1021	-	-
<b>Main bearing</b>	-	-	-

## Husqvarna® - 2 stroke



**New!**

Model	CR250 / WR250	CR250 / WR250	TC250
Years	92-98	98-05 / 98-12	2014
Displ. (cc)	249	249	249

Piston Kit Part No.	Piston size (mm)	Over size (mm)	Ring Set Part No.	Piston Kit Part No.	Piston size (mm)	Over size (mm)	Ring Set Part No.	Piston Kit Part No.	Piston size (mm)	Over size (mm)	Ring Set Part No.
8015DA	66,94	Std.	RDB6700	8141DA	66,34	Std.	RDB6640	8169DA	66,34	Std.	RDB6640
8015DB	66,95	+0,01	RDB6700	8141DB	66,35	+0,01	RDB6640	8169DB	66,35	+0,01	RDB6640
8015DC	66,96	+0,02	RDB6700	8141DC	66,36	+0,02	RDB6640	8169DC	66,36	+0,02	RDB6640
8015D050	67,44	+0,50	RDB6750								
8015D100	67,94	+1,00	RDB6800								

	set includes		
Clip Part No.	CW18	CW18	CW18
Pin Part No.	WP033	WP033	WP033
Rings	included	included	included
Price-Code	3	3	3
Stroke	-	72	72
Comp. Height (mm)	35	38	38

	extra parts		
Top End Gasket Kit	-	D2044-EST	-
Wössner Connecting rods	-	P2057 '99-11	-
Needle bearing	-	N1021	N1020
Main bearing	-	2 x MB6305C3	2 x MB6305C3

## Husqvarna® - 2 stroke



Model	WR300 / TE300	CR360 / WR360	CR390 / WR390 KH37mm
Years	09-13 / '14	92-02	77-80
Displ. (cc)	297	360	390

Piston Kit Part No.	Piston size (mm)	Over size (mm)	Ring Set Part No.	Piston Kit Part No.	Piston size (mm)	Over size (mm)	Ring Set Part No.	Piston Kit Part No.	Piston size (mm)	Over size (mm)	Ring Set Part No.
8250DA	71,94	Std.	RDB7200	8076DA	77,94	Std.	RDC7800	8033DA	82,92	Std.	RSC8300
8250DB	71,95	+0,01	RDB7200	8076DB	77,95	+0,01	RDC7800	8033D050	83,42	+0,50	RSC8350
8250DC	71,96	+0,02	RDB7200	8076DC	77,96	+0,02	RDC7800	8033D100	83,92	+1,00	RSC8400
				8076D050	78,44	+0,50	RDC7850	8033D150	84,42	+1,50	RSC8450
								8033D200	84,92	+2,00	RSC8500
								8033D250	85,42	+2,50	RSC8550

set includes			
Clip Part No.	CW18	CW18	CW18
Pin Part No.	WP033	WP039	WP033
Rings	included	included	included
Price-Code	6	6/1	6/1
Stroke	72	75	71
Comp. Height (mm)	38	27	37

extra parts			
Top End Gasket Kit	-	D2054-EST	-
Wössner Connecting rods	P2057	-	-
Needle bearing	N1020	N1049	-
Main bearing	2 x MB6305C3	-	-

## Husqvarna® - 2 stroke



Model	CR390 / WR390 KH35mm	WR430	CR500
Years	77-80	84-88	83-87
Displ. (cc)	390	-	500

Piston Kit Part No.	Piston size (mm)	Over size (mm)	Ring Set Part No.	Piston Kit Part No.	Piston size (mm)	Over size (mm)	Ring Set Part No.	Piston Kit Part No.	Piston size (mm)	Over size (mm)	Ring Set Part No.
8249DA	82,92	Std.	RSC8300	8051DA	85,92	Std.	RSC8600	8037D100	86,92	+1,00	RSC8700
8249D050	83,42	+0,50	RSC8350	8051DB	85,93	+0,01	RSC8600	8037D150	87,42	+1,50	RSC8750
8249D100	83,92	+1,00	RSC8400	8051DC	85,94	+0,02	RSC8600	8037D200	87,92	+2,00	RSC8800
8249D150	84,42	+1,50	RSC8450	8051D050	86,42	+0,50	RSC8650				
8249D200	84,92	+2,00	RSC8500	8051D100	86,92	+1,00	RSC8700				
8249D250	85,42	+2,50	RSC8550	8051D150	87,42	+1,50	RSC8750				

	set includes		
Clip Part No.	CW18	CW18	CW20
Pin Part No.	WP033	WP039	WP086
Rings	included	included	included
Price-Code	6/1	6/1	6/1
Stroke	71	74	84
Comp. Height (mm)	35	37	42

	extra parts		
Top End Gasket Kit	-	-	-
Wössner Connecting rods	-	-	-
Needle bearing	-	-	-
Main bearing	-	-	-

## Husqvarna® - 4 stroke



Verdichtungen beziehen sich auf Standardmaße „-DA“

Compression ratio refer to standard sizes “-DA”

**New!**

Model	TC250 Pro Series	TC250 / TE250	TC250 / TE250 / TXC250
Years	12-13	03-05	06-09
Displ. (cc)	249	249	249,5

Piston Kit Part No.	Piston size (mm)	Over size (mm)	Ring Set Part No.	Piston Kit Part No.	Piston size (mm)	Over size (mm)	Ring Set Part No.	Piston Kit Part No.	Piston size (mm)	Over size (mm)	Ring Set Part No.
8882DA	78,95	Std.	790XAS-2	8576DA	75,96	Std.	760XAS	8650DA	75,96	Std.	760XAS
8882DB	78,96	+0,01	790XAS-2	8576DB	75,97	+0,01	760XAS	8650DB	75,97	+0,01	760XAS
8882DC	78,97	+0,02	790XAS-2	8576DC	75,98	+0,02	760XAS	8650DC	75,98	+0,02	760XAS

set includes			
Clip Part No.	CW14	CW16	CW16
Pin Part No.	WP063	WP059	WP059
Rings	included	included	included
Price-Code	5/1	5	5
Stroke	50.9	55	55
Wössner/ OEM Comp. ratio	14:1 13.6:1	12.9:1 12.5:1	13:1 12.9:1
Dome Volume (CC)	+4.2 cm <sup>3</sup>	-3.1 cm <sup>3</sup>	-2.7 cm <sup>3</sup>
Comp. Height (mm)	18	23.50	20

extra parts			
Top End Gasket Kit	-	D4035-EST '03-04 D4036-EST '05-09	D4036-EST
Wössner Connecting rods	-	-	P4049
Needle bearing	-	-	-
Main bearing	-	-	-

## Husqvarna® - 4 stroke



Verdichtungen beziehen sich auf Standardmaße „-DA“

Compression ratio refer to standard sizes “-DA”

Model	TC250 Fuel injection '2011	FE250 <b>New!</b>	FC350 <b>New!</b>
Years	10-11	2014	2014
Displ. (cc)	249	249	350

Piston Kit Part No.	Piston size (mm)	Over size (mm)	Ring Set Part No.	Piston Kit Part No.	Piston size (mm)	Over size (mm)	Ring Set Part No.	Piston Kit Part No.	Piston size (mm)	Over size (mm)	Ring Set Part No.
8770DA	78,95	Std.	RIK79.00D	8865DA	77,96	Std.	König Ø 78-4T	8807DA	87,95	Std.	880XSY
8770DB	78,96	+0,01	RIK79.00D	8865DB	77,97	+0,01	König Ø 78-4T	8807DB	87,96	+0,01	880XSY
8770DC	78,97	+0,02	RIK79.00D	8865DC	77,98	+0,02	König Ø 78-4T	8807DC	87,97	+0,02	880XSY
								8807D200	89,95	+2,00	900XSY
								8807D300	90,95	+3,00	910XSY

	set includes		
Clip Part No.	CW14	CW16	CW18
Pin Part No.	WP063	WP070	WP053
Rings	included	included	included
Price-Code	5/1	5/2	7
Stroke	50.9	52.3	57.5
Wössner/ OEM Comp. ratio	14:1 13.6:1	13:9:1 13.9:1	13:5:1 13.5:1
Dome Volume (CC)	-0.6 cm <sup>3</sup>	-2.1 cm <sup>3</sup>	+1.25 cm <sup>3</sup>
Comp. Height (mm)	18	19.50	20.50

	extra parts		
Top End Gasket Kit	D4036-EST	-	-
Wössner Connecting rods	P4050	P4059	-
Needle bearing	-	-	-
Main bearing	-	-	-

## Husqvarna® - 4 stroke

Verdichtungen beziehen sich auf Standardmaße „-DA“

Compression ratio refer to standard sizes “-DA”

<b>Model</b>	FC350 Pro Series <b>New!</b>	TC310 / TE310	TC310 / TE310
<b>Years</b>	2014	09-10	11-12
<b>Displ. (cc)</b>	350	297	-

Piston Kit Part No.	Piston size (mm)	Over size (mm)	Ring Set Part No.	Piston Kit Part No.	Piston size (mm)	Over size (mm)	Ring Set Part No.	Piston Kit Part No.	Piston size (mm)	Over size (mm)	Ring Set Part No.
8810DA	87,95	Std.	880XS	8771DA	82,95	Std.	830XS	8867DA	81,95	Std.	820XS
8810DB	87,96	+0,01	880XS	8771DB	82,96	+0,01	830XS	8867DB	81,96	+0,01	820XS
8810DC	87,97	+0,02	880XS	8771DC	82,97	+0,02	830XS	8867DC	81,97	+0,02	820XS
8810D200	89,95	+2,00	900XS								

	set includes		
<b>Clip Part No.</b>	CW18	CW16	CW16
<b>Pin Part No.</b>	WP099	WP059	WP059
<b>Rings</b>	included	included	included
<b>Price-Code</b>	7	7/1	7/1
<b>Stroke</b>	57.5	55	57.3
<b>Wössner/ OEM Comp. ratio</b>	14.5:1 13.5:1	13:1 12.9:1	13:1 13:1
<b>Dome Volume (CC)</b>	+3.3 cm <sup>3</sup> / +2.1 cm <sup>3</sup>	-7.0 cm <sup>3</sup>	-5.4 cm <sup>3</sup>
<b>Comp. Height (mm)</b>	20.50	20	23

	extra parts		
<b>Top End Gasket Kit</b>	-	-	-
<b>Wössner Connecting rods</b>	-	P4049	-
<b>Needle bearing</b>	-	-	-
<b>Main bearing</b>	-	-	-

## Husqvarna® - 4 stroke



Verdichtungen beziehen sich auf Standardmaße „-DA“  
 Compression ratio refer to standard sizes “-DA”

Model	TE350	TC400 / SMR400	TE410
Years	90-97	99-01 / 05-07	93-95
Displ. (cc)	349	399	399

Piston Kit Part No.	Piston size (mm)	Over size (mm)	Ring Set Part No.	Piston Kit Part No.	Piston size (mm)	Over size (mm)	Ring Set Part No.	Piston Kit Part No.	Piston size (mm)	Over size (mm)	Ring Set Part No.
8510DA	83,94	Std.	840XSY	8550DA	91,44	Std.	915XSY	8515DA	91,44	Std.	915XSY
8510DB	83,95	+0,01	840XSY	8550DB	91,45	+0,01	915XSY	8515DB	91,45	+0,01	915XSY
8510DC	83,96	+0,02	840XSY	8550DC	91,46	+0,02	915XSY	8515DC	91,46	+0,02	915XSY

	set includes		
Clip Part No.	CW20	CW20	CW20
Pin Part No.	WP029	WP038	WP038
Rings	included	included	included
Price-Code	7/1	7/1	7/1
Stroke	63	60.8	60.8
Wössner/ OEM Comp. ratio	- 10.2:1	- 11.4:1	- 11.4:1
Dome Volume (CC)	3.6 cm <sup>3</sup>	+1.9 cm <sup>3</sup>	-1.9 cm <sup>3</sup>
Comp. Height (mm)	28	24.50	27.80

	extra parts		
Top End Gasket Kit	-	-	-
Wössner Connecting rods	-	-	-
Needle bearing	-	-	-
Main bearing	-	-	-



## Husqvarna® - 4 stroke



Verdichtungen beziehen sich auf Standardmaße „-DA“

Compression ratio refer to standard sizes “-DA”

Model	TE410	TE410	TE449 / TC449 / TXC449 Pro Series
Years	96-98	99-01	11-13
Displ. (cc)	399	399	449,6

Piston Kit Part No.	Piston size (mm)	Over size (mm)	Ring Set Part No.	Piston Kit Part No.	Piston size (mm)	Over size (mm)	Ring Set Part No.	Piston Kit Part No.	Piston size (mm)	Over size (mm)	Ring Set Part No.
8514DA	91,44	Std.	915XSY	8518DA	91,44	Std.	915XSY	8829DA	97,94	Std.	980XSY
8514DB	91,45	+0,01	915XSY	8518DB	91,45	+0,01	915XSY	8829DB	97,95	+0,01	980XSY
8514DC	91,46	+0,02	915XSY	8518DC	91,46	+0,02	915XSY	8829DC	97,96	+0,02	980XSY

set includes			
Clip Part No.	CW20	CW20	CW20
Pin Part No.	WP038	WP038	WP038
Rings	included	included	included
Price-Code	7/1	7/1	7
Stroke	60.8	60.8	59.6
Wössner/ OEM Comp. ratio	- 11.4:1	- 11.4:1	13:1 12:1 (TE449) - 13:1 (TC449)
Dome Volume (CC)	-2.5 cm <sup>3</sup>	-2.4 cm <sup>3</sup>	-0.5 cm <sup>3</sup>
Comp. Height (mm)	29.50	24.50	25

extra parts			
Top End Gasket Kit	-	-	-
Wössner Connecting rods	-	-	-
Needle bearing	-	-	-
Main bearing	-	-	-

## Husqvarna® - 4 stroke



Verdichtungen beziehen sich auf Standardmaße „-DA“

Compression ratio refer to standard sizes “-DA”

Model	TC450 / TE450	TC450 / TE450 / SMR450	TC450 / TE450 / SMR450
Years	02	03-05	06-10
Displ. (cc)	449	449	449

Piston Kit Part No.	Piston size (mm)	Over size (mm)	Ring Set Part No.	Piston Kit Part No.	Piston size (mm)	Over size (mm)	Ring Set Part No.	Piston Kit Part No.	Piston size (mm)	Over size (mm)	Ring Set Part No.
8556DA	96,94	Std.	970XSY	8578DA	96,94	Std.	970XSY	8651DA	96,96	Std.	970ADS-2
8556DB	96,95	+0,01	970XSY	8578DB	96,95	+0,01	970XSY	8651DB	96,97	+0,01	970ADS-2
8556DC	96,96	+0,02	970XSY	8578DC	96,96	+0,02	970XSY	8651DC	96,98	+0,02	970ADS-2

	set includes		
Clip Part No.	CW20	CW20	CW20
Pin Part No.	WP038	WP038	WP038
Rings	included	included	included
Price-Code	7/1	7/1	7/1
Stroke	60.8	60.8	60.8
Wössner/ OEM Comp. ratio	12:1	12:1	13:1 12.9:1
Dome Volume (CC)	-5.1 cm <sup>3</sup>	-6.5 cm <sup>3</sup>	-5.7 cm <sup>3</sup>
Comp. Height (mm)	24.50	24.50	24.50

	extra parts		
Top End Gasket Kit	-	D4037-EST	D4037-EST `03-09
Wössner Connecting rods	-	SMR = P4015 `04-07	SMR = P4015 `04-07
Needle bearing	-	-	-
Main bearing	-	-	-

## Husqvarna® - 4 stroke



Verdichtungen beziehen sich auf Standardmaße „-DA“

Compression ratio refer to standard sizes “-DA”

<b>Model</b>	FC450 <b>New!</b>	FC450 Pro Series <b>New!</b>
<b>Years</b>	2014	2014
<b>Displ. (cc)</b>	449	449

Piston Kit Part No.	Piston size (mm)	Over size (mm)	Ring Set Part No.	Piston Kit Part No.	Piston size (mm)	Over size (mm)	Ring Set Part No.
8868DA	94,95	Std.	950ADS-2	8873DA	94,95	Std.	950ADS-2
8868DB	94,96	+0,01	950ADS-2	8873DB	94,96	+0,01	950ADS-2
8868DB	94,97	+0,02	950ADS-2	8873DC	94,97	+0,02	950ADS-2

set includes		
<b>Clip Part No.</b>	CW19	CW19
<b>Pin Part No.</b>	WP071	WP071
<b>Rings</b>	included	included
<b>Price-Code</b>	7/1	7/1
<b>Stroke</b>	63.4	63.4
<b>Wössner/ OEM Comp. ratio</b>	12.6:1 12.6:1	13.6:1 12.6:1
<b>Dome Volume (CC)</b>	+1 cm <sup>3</sup>	+4.05 cm <sup>3</sup>
<b>Comp. Height (mm)</b>	22.80	22.80

extra parts		
<b>Top End Gasket Kit</b>	D4061-EST '13	D4061-EST
<b>Wössner Connecting rods</b>	P4058	P4058
<b>Needle bearing</b>	-	-
<b>Main bearing</b>	-	-

## Husqvarna® - 4 stroke

Verdichtungen beziehen sich auf Standardmaße „-DA“

Compression ratio refer to standard sizes “-DA”

Model	TE510 / TC510 / WRE510	TC510 / TE510 / SMR510	TC510 / TE510 / SMR510 2. Ring
Years	87-90	06-09 / 08-10 / 08-10	06-09 / 08-10 / 08-10
Displ. (cc)	503	501	501

Piston Kit Part No.	Piston size (mm)	Over size (mm)	Ring Set Part No.	Piston Kit Part No.	Piston size (mm)	Over size (mm)	Ring Set Part No.	Piston Kit Part No.	Piston size (mm)	Over size (mm)	Ring Set Part No.
8511DA	91,44	Std.	915XS	8652DA	96,95	Std.	970XS	8866DA	96,95	Std.	970XS
8511DB	91,45	+0,01	915XS	8652DB	96,96	+0,01	970XS	8866DB	96,96	+0,01	970XS
8511DC	91,46	+0,02	915XS	8652DC	96,97	+0,02	970XS	8866DC	96,97	+0,02	970XS
8511D050	91,94	+0,50	920XS								

	set includes		
Clip Part No.	CW20	CW20	CW20
Pin Part No.	WP038	WP038	WP038
Rings	included	included	included
Price-Code	7/1	7/1	7/1
Stroke	76.5	67.8	67.8
Wössner/ OEM Comp. ratio	- 12:1	13:1 12.9:1	13:1 12.9:1
Dome Volume (CC)	-2.6 cm <sup>3</sup>	-9.2 cm <sup>3</sup>	-9.2 cm <sup>3</sup>
Comp. Height (mm)	30	24.80	24.80

	extra parts		
Top End Gasket Kit	-	D4038-EST '05-09	D4038-EST '05-09
Wössner Connecting rods	-	P4054	P4054
Needle bearing	-	-	-
Main bearing	-	-	-

## Husqvarna® - 4 stroke



Verdichtungen beziehen sich auf Standardmaße „-DA“  
 Compression ratio refer to standard sizes “-DA”

Model	TE511 / TXC511 / SMR511	TC570 / TE570	TC610 / TE610
Years	11-13	01-02 / 01-02	91-98
Displ. (cc)	477,5	577	577

Piston Kit Part No.	Piston size (mm)	Over size (mm)	Ring Set Part No.	Piston Kit Part No.	Piston size (mm)	Over size (mm)	Ring Set Part No.	Piston Kit Part No.	Piston size (mm)	Over size (mm)	Ring Set Part No.
8828DA	100,94	Std.	1010XS	8526DA	97,94	Std.	980ADS-2	8522DA	97,94	Std.	980XS
8828DB	100,95	+0,01	1010XS	8526DB	97,95	+0,01	980ADS-2	8522DB	97,95	+0,01	980XS
8828DC	100,96	+0,02	1010XS	8526DC	97,96	+0,02	980ADS-2	8522DC	97,96	+0,02	980XS
				8526D200	99,94	+2,00	1000ADS-2	8522D200	99,94	+2,00	1000XS
								8522D400	101,94	+4,00	1020XSU

	set includes		
Clip Part No.	CW20	CW22	CW22
Pin Part No.	WP038	WP009	WP009
Rings	included	included	included
Price-Code	7/1	7/1	7/1
Stroke	59.6	76.4	76.4
Wössner/ OEM Comp. ratio	12:1 12:1	- 10:1	-
Dome Volume (CC)	-6 cm <sup>3</sup>	-5.4 cm <sup>3</sup>	-1.8 cm <sup>3</sup>
Comp. Height (mm)	25	25	30

	extra parts		
Top End Gasket Kit	-	-	D4012-EST `92-01
Wössner Connecting rods	-	P4042	P4041
Needle bearing	-	-	-
Main bearing	-	-	-

## Husqvarna® - 4 stroke



Verdichtungen beziehen sich auf Standardmaße „-DA“  
 Compression ratio refer to standard sizes “-DA”

Model	TC610 / TE610	TC610 / TE610 Pro Series	TC610 / TE610
Years	99-03 / 99-03	99-05	06-10
Displ. (cc)	577	577	577

Piston Kit Part No.	Piston size (mm)	Over size (mm)	Ring Set Part No.	Piston Kit Part No.	Piston size (mm)	Over size (mm)	Ring Set Part No.	Piston Kit Part No.	Piston size (mm)	Over size (mm)	Ring Set Part No.
8526DA	97,94	Std.	980ADS-2	8568DA	97,94	Std.	980XSY	8815DA	97,94	Std.	980XSY
8526DB	97,95	+0,01	980ADS-2	8568DB	97,95	+0,01	980XSY	8815DB	97,95	+0,01	980XSY
8526DC	97,96	+0,02	980ADS-2	8568DC	97,96	+0,02	980XSY	8815DC	97,96	+0,02	980XSY
8526D200	99,94	+2,00	1000ADS-2	8568D200	99,94	+2,00	1000XSY	8815D200	99,94	+2,00	1000XSY
8526D300	100,94	+3,00	1010XSY								
8526D400	101,94	+4,00	1020XSU								

set includes			
Clip Part No.	CW22	CW22	CW22
Pin Part No.	WP009	WP009	WP009
Rings	included	included	included
Price-Code	7/1	7/1	7/1
Stroke	76.4	76.4	76.4
Wössner/ OEM Comp. ratio	10:1 10:1	11:1 10:1	- 11:1
Dome Volume (CC)	-5.4 cm <sup>3</sup>	+8.2 cm <sup>3</sup>	+8.2 cm <sup>3</sup>
Comp. Height (mm)	25	25	25

extra parts			
Top End Gasket Kit	D4012-EST '92-01	D4012-EST '92-01	-
Wössner Connecting rods	P4042	P4042	P4042
Needle bearing	-	-	-
Main bearing	-	-	-

## Husqvarna<sup>®</sup> - 4 stroke

Verdichtungen beziehen sich auf Standardmaße „-DA“

*Compression ratio refer to standard sizes “-DA”*

## Kawasaki® - 2 stroke



Model	KX60	KX65	KX80
Years	83-03	00-14	82-83
Displ. (cc)	60	65	82

Piston Kit Part No.	Piston size (mm)	Over size (mm)	Ring Set Part No.	Piston Kit Part No.	Piston size (mm)	Over size (mm)	Ring Set Part No.	Piston Kit Part No.	Piston size (mm)	Over size (mm)	Ring Set Part No.
8232DA	42,95	Std.	RSB4300	8196DA	44,45	Std.	RSB4450	8200DA	47,95	Std.	RSB4800
8232D050	43,45	+0,50	RSB4350	8196DB	44,46	+0,01	RSB4450	8200D050	48,45	+0,50	RSB4850
8232D100	43,95	+1,00	RSB4400	8196DC	44,47	+0,02	RSB4450	8200D100	48,95	+1,00	RSB4900
8232D200	44,95	+2,00	RSB4500	8196DD	44,48	+0,03	RSB4450				

set includes			
Clip Part No.	CW12	CW12	CW14
Pin Part No.	WP091	WP091	WP058
Rings	included	included	included
Price-Code	1/1	1	1/1
Stroke	41.6	41.6	45.8
Comp. Height (mm)	23.5	23.60	26

extra parts			
Top End Gasket Kit	-	D2011-EST '00-09	-
Wössner Connecting rods	P2001	P2001 '00-14	P2036 '82-97
Needle bearing	N1036	N1036	N1007
Main bearing	2 x MB6304C3	2 x MB6304C3	2 x MB6304C3



## Kawasaki® - 2 stroke



Model	KX80	KX80 U.S. Bore	KX80 International Bore
Years	84-85	88-00	88-00
Displ. (cc)	82	82	79

Piston Kit Part No.	Piston size (mm)	Over size (mm)	Ring Set Part No.	Piston Kit Part No.	Piston size (mm)	Over size (mm)	Ring Set Part No.	Piston Kit Part No.	Piston size (mm)	Over size (mm)	Ring Set Part No.
8201DA	47,95	Std.	RDB4800	8197DA	47,95	Std.	RSB4800	8234DA	46,95	Std.	RSB4700
8201D050	48,45	+0,50	RDB4850	8197DB	47,96	+0,01	RSB4800	8234DB	46,96	+0,01	RSB4700
8201D100	48,95	+1,00	RDB4900	8197DC	47,97	+0,02	RSB4800	8234DC	46,97	+0,02	RSB4700
				8197D050	48,45	+0,50	RSB4850				
				8197D100	48,95	+1,00	RSB4900				
				8197D400	51,95	+4,00	RSB5200				
				8197D450	52,45	+4,50	RSB5250				

	set includes		
Clip Part No.	CW14	CW14	CW14
Pin Part No.	WP058	WP058	WP058
Rings	included	included	included
Price-Code	1/1	1/1	1
Stroke	45.8	45.8	45.8
Comp. Height (mm)	-	26	26

	extra parts		
Top End Gasket Kit	-	-	-
Wössner Connecting rods	P2036 `82-97	P2005 `98-00	P2036 `82-97 P2005 `98-00
Needle bearing	N1007	N1007	N1007
Main bearing	2 x MB6304C3	2 x MB6304C3	2 x MB6304C3

## Kawasaki® - 2 stroke



Model	KX85	KX100	KX125
Years	01-14	95-14	78-81
Displ. (cc)	85	100	125

Piston Kit Part No.	Piston size (mm)	Over size (mm)	Ring Set Part No.	Piston Kit Part No.	Piston size (mm)	Over size (mm)	Ring Set Part No.	Piston Kit Part No.	Piston size (mm)	Over size (mm)	Ring Set Part No.
8102DA	48,45	Std.	RSB4850	8254DA	52,45	Std.	RSB5250	8202DA	55,94	Std.	RDB5600
8102DB	48,46	+0,01	RSB4850	8254D050	52,95	+0,50	RSB5300	8202D050	56,44	+0,50	RDB5650
8102DC	48,47	+0,02	RSB4850	8254D100	53,45	+1,00	RSB5350				
8102D350	51,95	+3,50	RSB5200	8254D150	53,95	+1,50	RSB5400				
8102D400	52,45	+4,00	RSB5250	8254D200	54,45	+2,00	RSB5450				
8102D450	52,95	+4,50	RSB5300								

set includes			
Clip Part No.	CW14	CW14	CW16
Pin Part No.	WP058	WP025	WP036
Rings	included	included	included
Price-Code	1	1	2/1
Stroke	45.8	45.8	50.8
Comp. Height (mm)	26	26	29.7

extra parts			
Top End Gasket Kit	D2012-EST `01-13	D2080-EST `98-13	-
Wössner Connecting rods	P2005 `01-14	P2036 `82-97 P2005 `98-13	P2037
Needle bearing	N1007	N1007	N1013
Main bearing	2 x MB6304C3	2 x MB6304C3	2 x MB6304C3

## Kawasaki® - 2 stroke



<b>Model</b>	KX125	KX125	KX125
<b>Years</b>	82-85	86	87
<b>Displ. (cc)</b>	125	125	125

Piston Kit Part No.	Piston size (mm)	Over size (mm)	Ring Set Part No.	Piston Kit Part No.	Piston size (mm)	Over size (mm)	Ring Set Part No.	Piston Kit Part No.	Piston size (mm)	Over size (mm)	Ring Set Part No.
8210DA	55,94	Std.	RDB5600	8211DA	55,94	Std.	RSB5600	8128DA	55,94	Std.	RSB5600
8210DB	55,95	+0,01	RDB5600	8211DB	55,95	+0,01	RSB5600	8128DB	55,95	+0,01	RSB5600
8210D050	56,44	+0,50	RDB5650	8211D050	56,44	+0,50	RSB5650	8128D050	56,44	+0,50	RSB5650
8210D100	56,94	+1,00	RDB5700	8211D100	56,94	+1,00	RSB5700	8128D100	56,94	+1,00	RSB5700
								8128D150	57,44	+1,50	RSB5750
								8128D200	57,94	+2,00	RSB5800

	set includes		
<b>Clip Part No.</b>	CW16	CW16	CW16
<b>Pin Part No.</b>	WP036	WP036	WP036
<b>Rings</b>	included	included	included
<b>Price-Code</b>	2/1	2/1	2/1
<b>Stroke</b>	50.6	50.6	50.6
<b>Comp. Height (mm)</b>	29.7	29.7	29.50

	extra parts		
<b>Top End Gasket Kit</b>	-	-	-
<b>Wössner Connecting rods</b>	P2037	P2037	P2037
<b>Needle bearing</b>	N1016	N1016	N1016
<b>Main bearing</b>	1 x MB6305C3 Left 1 x MB6304C3 Right `82-84 1 x MB6322C3 Right `85-87	1 x MB6305C3 Left 1 x MB6322C3 Right	1 x MB6305C3 Left 1 x MB6322C3 Right

## Kawasaki® - 2 stroke



<b>Model</b>	KX125	KX125	KX125
<b>Years</b>	88-89	90	91
<b>Displ. (cc)</b>	125	125	125

Piston Kit Part No.	Piston size (mm)	Over size (mm)	Ring Set Part No.	Piston Kit Part No.	Piston size (mm)	Over size (mm)	Ring Set Part No.	Piston Kit Part No.	Piston size (mm)	Over size (mm)	Ring Set Part No.
8130DA	55,94	Std.	RSB5600	8106DA	55,94	Std.	RSB5600	8108DA	55,94	Std.	RSB5600
8130DB	55,95	+0,01	RSB5600	8106DB	55,95	+0,01	RSB5600	8108DB	55,95	+0,01	RSB5600
8130DC	55,96	+0,02	RSB5600	8106D050	56,44	+0,50	RSB5650	8108D050	56,44	+0,50	RSB5650
8130D050	56,44	+0,50	RSB5650	8106D100	56,94	+1,00	RSB5700	8108D100	56,94	+1,00	RSB5700
8130D100	56,94	+1,00	RSB5700								

set includes			
<b>Clip Part No.</b>	CW16	CW16	CW16
<b>Pin Part No.</b>	WP036	WP036	WP036
<b>Rings</b>	included	included	included
<b>Price-Code</b>	2	2	2
<b>Stroke</b>	50.6	50.6	50.6
<b>Comp. Height (mm)</b>	29.50	29.50	29.50

extra parts			
<b>Top End Gasket Kit</b>	-	D2048-EST	D2048-EST
<b>Wössner Connecting rods</b>	P2033	P2033	P2033
<b>Needle bearing</b>	N1016	N1016	N1016
<b>Main bearing</b>	2 x MB6322C4	2 x MB6322C4	2 x MB6322C4

## Kawasaki® - 2 stroke



<b>Model</b>	KX125	KX125	KX125
<b>Years</b>	92-93	94	95-97
<b>Displ. (cc)</b>	125	125	125

Piston Kit Part No.	Piston size (mm)	Over size (mm)	Ring Set Part No.	Piston Kit Part No.	Piston size (mm)	Over size (mm)	Ring Set Part No.	Piston Kit Part No.	Piston size (mm)	Over size (mm)	Ring Set Part No.
8110DA	53,94	Std.	RSB5400	8111DA	53,94	Std.	RSB5400	8112DA	53,94	Std.	RSB5400
8110DB	53,95	+0,01	RSB5400	8111DB	53,95	+0,01	RSB5400	8112DB	53,95	+0,01	RSB5400
8110DC	53,96	+0,02	RSB5400	8111DC	53,96	+0,02	RSB5400	8112DC	53,96	+0,02	RSB5400
8110D050	54,44	+0,50	RSB5450	8111D050	54,44	+0,50	RSB5450	8112D050	54,44	+0,50	RSB5450
8110D100	54,94	+1,00	RSB5500	8111D100	54,94	+1,00	RSB5500	8112D100	54,94	+1,00	RSB5500
								8112D200	55,94	+2,00	RSB5600

set includes			
<b>Clip Part No.</b>	CW16	CW15	CW15
<b>Pin Part No.</b>	WP036	WP032	WP032
<b>Rings</b>	included	included	included
<b>Price-Code</b>	2	2/1	2
<b>Stroke</b>	54.5	54.5	54.5
<b>Comp. Height (mm)</b>	29	29.50	29.50

extra parts			
<b>Top End Gasket Kit</b>	D2075-EST	D2075-EST	D2075-EST
<b>Wössner Connecting rods</b>	P2037	P2010	P2010
<b>Needle bearing</b>	N1016	N1010	N1010
<b>Main bearing</b>	2 x MB6322C4	2 x MB6322C4	2 x MB6322C4

## Kawasaki® - 2 stroke



<b>Model</b>	KX125	KX125	KX125
<b>Years</b>	98	99-00	01-02
<b>Displ. (cc)</b>	125	125	125

Piston Kit Part No.	Piston size (mm)	Over size (mm)	Ring Set Part No.	Piston Kit Part No.	Piston size (mm)	Over size (mm)	Ring Set Part No.	Piston Kit Part No.	Piston size (mm)	Over size (mm)	Ring Set Part No.
8113DA	53,94	Std.	RSB5400	8057DA	53,95	Std.	RSB5400	8062DA	53,95	Std.	RSB5400
8113DB	53,95	+0,01	RSB5400	8057DB	53,96	+0,01	RSB5400	8062DB	53,96	+0,01	RSB5400
8113DC	53,96	+0,02	RSB5400	8057DC	53,97	+0,02	RSB5400	8062DC	53,97	+0,02	RSB5400
8113D200	55,94	+2,00	RSB5600	8057D200	55,95	+2,00	RSB5600	8062D200	55,95	+2,00	RSB5600

set includes			
<b>Clip Part No.</b>	CW15	CW15	CW15
<b>Pin Part No.</b>	WP032	WP032	WP032
<b>Rings</b>	included	included	included
<b>Price-Code</b>	2/1	2	2
<b>Stroke</b>	54.5	54.5	54.5
<b>Comp. Height (mm)</b>	29.50	29.30	29.30

extra parts			
<b>Top End Gasket Kit</b>	D2049-EST	D2049-EST '98-99 D2071-EST '00-02	D2071-EST
<b>Wössner Connecting rods</b>	P2034	P2034	P2034
<b>Needle bearing</b>	N1010	N1010	N1010
<b>Main bearing</b>	2 x MB6322C4	2 x MB6322C4	2 x MB6322C4

## Kawasaki® - 2 stroke



Model	KX125	KX125	KMX125
Years	03	04-08	86-05
Displ. (cc)	125	125	125

Piston Kit Part No.	Piston size (mm)	Over size (mm)	Ring Set Part No.	Piston Kit Part No.	Piston size (mm)	Over size (mm)	Ring Set Part No.	Piston Kit Part No.	Piston size (mm)	Over size (mm)	Ring Set Part No.
8073DA	53,95	Std.	RSB5400	8167DA	53,95	Std.	RSB5400	8007DA	53,94	Std.	RDB5400
8073DB	53,96	+0,01	RSB5400	8167DB	53,96	+0,01	RSB5400	8007DB	53,95	+0,01	RDB5400
8073DC	53,97	+0,02	RSB5400	8167DC	53,97	+0,02	RSB5400	8007DC	53,96	+0,02	RDB5400
8073D200	55,95	+2,00	RSB5600	8167D200	55,95	+2,00	RSB5600	8007D050	54,44	+0,50	RDB5450
								8007D100	54,94	+1,00	RDB5500
								8007D200	55,94	+2,00	RDB5600

set includes			
Clip Part No.	CW15	CW15	CW16
Pin Part No.	WP032	WP032	WP036
Rings	included	included	included
Price-Code	2	2	2
Stroke	54.5	54.5	54.4
Comp. Height (mm)	29.30	29.30	32.8

extra parts			
Top End Gasket Kit	D2013-EST	D2013-EST	D2047-EST '91-93
Wössner Connecting rods	P2010	P2010	-
Needle bearing	N1010	N1010	N1016
Main bearing	2 x MB6322C4	2 x MB6322C4	-

## Kawasaki® - 2 stroke



Model	KDX125	KD125 / KE125 / KS125	KDX200
Years	90-05	74-84	86-06
Displ. (cc)	125	125	198

Piston Kit Part No.	Piston size (mm)	Over size (mm)	Ring Set Part No.	Piston Kit Part No.	Piston size (mm)	Over size (mm)	Ring Set Part No.	Piston Kit Part No.	Piston size (mm)	Over size (mm)	Ring Set Part No.
8008DA	55,94	Std.	RDB5600	8032DA	55,94	Std.	RDB5600	8093DA	65,94	Std.	RDB6600
8008DB	55,95	+0,01	RDB5600	8032D050	56,44	+0,50	RDB5650	8093DB	65,95	+0,01	RDB6600
8008DC	55,96	+0,02	RDB5600	8032D100	56,94	+1,00	RDB5700	8093DC	65,96	+0,02	RDB6600
8008D050	56,44	+0,50	RDB5650	8032D150	57,44	+1,50	RDB5750	8093D050	66,44	+0,50	RDB6650
8008D100	56,94	+1,00	RDB5700	8032D200	57,94	+2,00	RDB5800	8093D100	66,94	+1,00	RDB6700
								8093D200	67,94	+2,00	RDB6800

	set includes		
Clip Part No.	CW16	CW14	CW16
Pin Part No.	WP036	WP025	WP027
Rings	included	included	included
Price-Code	2	2	3
Stroke	50.6	50.6	58
Comp. Height (mm)	29.5	34	32

	extra parts		
Top End Gasket Kit	D2058-EST	-	-
Wössner Connecting rods	P2033	-	P2033 '89-06
Needle bearing	N1016	-	N1016
Main bearing	-	-	-



## Kawasaki® - 2 stroke



Model	KDX220R	KDX250 / KX250	KR1 250
Years	98-05	80-82 / 78-86	88-93
Displ. (cc)	216	249	249

Piston Kit Part No.	Piston size (mm)	Over size (mm)	Ring Set Part No.	Piston Kit Part No.	Piston size (mm)	Over size (mm)	Ring Set Part No.	Piston Kit Part No.	Piston size (mm)	Over size (mm)	Ring Set Part No.
8092DA	68,94	Std.	RDB6900	8203DA	69,94	Std.	RDB7000	8043DA	55,94	Std.	RDB5600
8092DB	68,95	+0,01	RDB6900	8203D050	70,44	+0,50	RDB7050	8043D050	56,44	+0,50	RDB5650
8092DC	68,96	+0,02	RDB6900	8203D100	70,94	+1,00	RDB7100				
8092D100	69,94	+1,00	RDB7000	8203D150	71,44	+1,50	RDB7150				
				8203D200	71,94	+2,00	RDB7200				

	set includes		
Clip Part No.	CW16	CW18	CW16
Pin Part No.	WP027	WP033	WP036
Rings	included	included	included
Price-Code	3	3/1	2
Stroke	58	64.9	50.6
Comp. Height (mm)	32	31.5	29.5

	extra parts		
Top End Gasket Kit	-	-	-
Wössner Connecting rods	P2033 '97-05	-	-
Needle bearing	N1016	-	-
Main bearing	2 x MB6305JR2	2 x MB6305C3	-

## Kawasaki® - 2 stroke



<b>Model</b>	KX250	KX250 / KDX250	KX250
<b>Years</b>	87-89	90-94 / 90-94	92-01
<b>Displ. (cc)</b>	249	250	249

Piston Kit Part No.	Piston size (mm)	Over size (mm)	Ring Set Part No.	Piston Kit Part No.	Piston size (mm)	Over size (mm)	Ring Set Part No.	Piston Kit Part No.	Piston size (mm)	Over size (mm)	Ring Set Part No.
8129DA	67,34	Std.	RDB6740	8109DA	67,34	Std.	RDB6740	8026DA	66,34	Std.	RDB6640
8129DB	67,35	+0,01	RDB6740	8109DB	67,35	+0,01	RDB6740	8026DB	66,35	+0,01	RDB6640
8129D060	67,94	+0,60	RDB6800	8109DC	67,36	+0,02	RDB6740	8026DC	66,36	+0,02	RDB6640
8129D110	68,44	+1,10	RDB6850	8109D060	67,94	+0,60	RDB6800	8026D060	66,94	+0,60	RDB6700
8129D160	68,94	+1,60	RDB6900	8109D110	68,44	+1,10	RDB6850	8026D110	67,44	+1,10	RDB6750
8129D210	69,44	+2,10	RDB6950					8026D160	67,94	+1,60	RDB6800
								8026D210	68,44	+2,10	RDB6850

set includes			
<b>Clip Part No.</b>	CW18	CW18	CW18
<b>Pin Part No.</b>	WP033	WP033	WP033
<b>Rings</b>	included	included	included
<b>Price-Code</b>	3/1	3	3
<b>Stroke</b>	70	70	72
<b>Comp. Height (mm)</b>	37	37	37

extra parts			
<b>Top End Gasket Kit</b>	D2066-EST	D2066-EST `88-92	D2066-EST `88-92 D2014-EST `01-04
<b>Wössner Connecting rods</b>	P2022	P2022	P2022
<b>Needle bearing</b>	N1049	N1049	N1049
<b>Main bearing</b>	2 x MB6328C3	2 x MB6328C3	2 x MB6328C3

## Kawasaki® - 2 stroke



Model	KX250	KX250	KX500
Years	02-04	05-08	88-04
Displ. (cc)	249	249	500

Piston Kit Part No.	Piston size (mm)	Over size (mm)	Ring Set Part No.	Piston Kit Part No.	Piston size (mm)	Over size (mm)	Ring Set Part No.	Piston Kit Part No.	Piston size (mm)	Over size (mm)	Ring Set Part No.
8088DA	66,34	Std.	RDB6640	8168DA	66,34	Std.	RDB6640	8228DA	85,93	Std.	RDC8600
8088DB	66,35	+0,01	RDB6640	8168DB	66,35	+0,01	RDB6640	8228D050	86,43	+0,50	RDC8650
8088DC	66,36	+0,02	RDB6640	8168DC	66,36	+0,02	RDB6640	8228D100	86,93	+1,00	RDC8700
8088D110	67,44	+1,10	RDB6750	8168DD	66,37	+0,03	RDB6640	8228D150	87,43	+1,50	RDC8750
				8168D210	68,44	+2,10	RDB6850	8228D200	87,93	+2,00	RDC8800
								8228D400	89,93	+4,00	RDC9000
								8228D500	90,93	+5,00	RDC9100

	set includes		
Clip Part No.	CW18	CW18	CW19
Pin Part No.	WP033	WP033	WP019
Rings	included	included	included
Price-Code	3	3	6/1
Stroke	72	72	86
Comp. Height (mm)	37	37	37.50

	extra parts		
Top End Gasket Kit	D2014-EST	D2015-EST	D2027-EST `89-01
Wössner Connecting rods	P2022	P2022	P2039 `85-04
Needle bearing	N1049	N1049	N1052
Main bearing	2 x MB6328C4	2 x MB6328C4	2 x MB6306C3

## Kawasaki® - 4 stroke



Verdichtungen beziehen sich auf Standardmaße „-DA“  
 Compression ratio refer to standard sizes “-DA”

Model	KX250F	KX250F	KX250F Pro-Series
Years	04-05	06-09	06-09
Displ. (cc)	249	250	250

Piston Kit Part No.	Piston size (mm)	Over size (mm)	Ring Set Part No.	Piston Kit Part No.	Piston size (mm)	Over size (mm)	Ring Set Part No.	Piston Kit Part No.	Piston size (mm)	Over size (mm)	Ring Set Part No.
8582DA	76,96	Std.	770XAS-2	8635DA	76,96	Std.	770XAS-2	8686DA	76,96	Std.	770XAS-2
8582DB	76,97	+0,01	770XAS-2	8635DB	76,97	+0,01	770XAS-2	8686DB	76,97	+0,01	770XAS-2
8582DC	76,98	+0,02	770XAS-2	8635DC	76,98	+0,02	770XAS-2	8686DC	76,98	+0,02	770XAS-2
8582D600	82,96	+6,00	830XSY	8635D300	79,96	+3,00	800XDS				
				8635D600	82,96	+6,00	830XDS				

	set includes		
Clip Part No.	CW16	CW16	CW16
Pin Part No.	WP059	WP059	WP070
Rings	included	included	included
Price-Code	DA - DC = 5 / D600 = 7	5	5
Stroke	53.6	53.6	53.6
Wössner/ OEM Comp. ratio	12,1:1 12.6:1	13.5:1 13.2:1	13.9:1 13.2:1
Dome Volume (CC)	-5.85 cm <sup>3</sup>	DA = -3.9 cm <sup>3</sup> D300 = -5.4 cm <sup>3</sup> D600 = -7.1 cm <sup>3</sup>	-3.37 cm <sup>3</sup>
Comp. Height (mm)	19.60	19.60	19.60

	extra parts		
Top End Gasket Kit	-	D4013-EST `04-08 D4014-EST `09-11	D4013-EST `04-08 D4014-EST `09-11
Wössner Connecting rods	P4002	P4002	P4002
Needle bearing	-	-	-
Main bearing	2 x MB6206RSI	2 x MB6206RSI	2 x MB6206RSI

## Kawasaki® - 4 stroke



Verdichtungen beziehen sich auf Standardmaße „-DA“  
 Compression ratio refer to standard sizes “-DA”

Model	KX250F	KX250F Pro Series	KX250F
Years	10	10	11-13
Displ. (cc)	250	250	249

Piston Kit Part No.	Piston size (mm)	Over size (mm)	Ring Set Part No.	Piston Kit Part No.	Piston size (mm)	Over size (mm)	Ring Set Part No.	Piston Kit Part No.	Piston size (mm)	Over size (mm)	Ring Set Part No.
8777DA	76,96	Std.	770XAS-2	8778DA	76,96	Std.	770XAS-2	8814DA	76,96	Std.	770XAS-2
8777DB	76,97	+0,01	770XAS-2	8778DB	76,97	+0,01	770XAS-2	8814DB	76,97	+0,01	770XAS-2
8777DC	76,98	+0,02	770XAS-2	8778DC	76,98	+0,02	770XAS-2	8814DC	76,98	+0,02	770XAS-2
8777D300	79,96	+3,00	800XDS					8814D300	79,96	+3,00	800XAS-2

	set includes		
Clip Part No.	CW16	CW16	CW16
Pin Part No.	WP070	WP070	WP070
Rings	included	included	included
Price-Code	5	5	5
Stroke	53.6	53.6	53.6
Wössner/ OEM Comp. ratio	13.2:1 13.2:1	13.9:1 13.2:1	13.5:1 13.5:1
Dome Volume (CC)	-2.5 cm <sup>3</sup>	-1.4 cm <sup>3</sup>	-2.8 cm <sup>3</sup>
Comp. Height (mm)	19.60	19.60	19.60

	extra parts		
Top End Gasket Kit	D4014-EST	D4014-EST	D4014-EST
Wössner Connecting rods	P4039 `10-14	P4039 `10-14	P4039 `10-14
Needle bearing	-	-	-
Main bearing	2 x MB6206RSI	2 x MB6206RSI	2 x MB6206RSI

## Kawasaki® - 4 stroke



Verdichtungen beziehen sich auf Standardmaße „-DA“  
 Compression ratio refer to standard sizes “-DA”

Model	KX250F Pro Series	KLX300R	KLX400R
Years	11-14	97-06	03-
Displ. (cc)	250	290 / 292	398

Piston Kit Part No.	Piston size (mm)	Over size (mm)	Ring Set Part No.	Piston Kit Part No.	Piston size (mm)	Over size (mm)	Ring Set Part No.	Piston Kit Part No.	Piston size (mm)	Over size (mm)	Ring Set Part No.
8816DA	76,96	Std.	770XAS-2	8644DA	77,94	Std.	780XDS	8565DA	89,94	Std.	900XSY
8816DB	76,97	+0,01	770XAS-2	8644D200	79,94	+2,00	800XDS	8565DB	89,95	+0,01	900XSY
8816DC	76,98	+0,02	770XAS-2					8565DC	89,96	+0,02	900XSY
								8565D400	93,94	+4,00	940XSY

	set includes		
Clip Part No.	CW16	CW17	CW20
Pin Part No.	WP070	WP090	WP029
Rings	included	included	included
Price-Code	5	7/1	7/1
Stroke	53.6	61.2	62.6
Wössner/ OEM Comp. ratio	14.2:1 13.5:1	- 11:1	- 12.2:1
Dome Volume (CC)	-1.7 cm <sup>3</sup>	DA = -4.8 cm <sup>3</sup> D200 = -6.4 cm <sup>3</sup>	DA - DC = -2.0 cm <sup>3</sup> D400 = -5.3 cm <sup>3</sup>
Comp. Height (mm)	19.60	23	25.3

	extra parts		
Top End Gasket Kit	D4014-EST	-	D4023-EST
Wössner Connecting rods	P4039 `10-14	-	P4009
Needle bearing	-	-	-
Main bearing	2 x MB6206RSI	-	-

## Kawasaki® - 4 stroke



Verdichtungen beziehen sich auf Standardmaße „-DA“

Compression ratio refer to standard sizes “-DA”

Model	KLX400R ProSeries 2. Ring	KX450F	KX450F Pro Series
Years	03-	06-08	06-08
Displ. (cc)	398	449	449

Piston Kit Part No.	Piston size (mm)	Over size (mm)	Ring Set Part No.	Piston Kit Part No.	Piston size (mm)	Over size (mm)	Ring Set Part No.	Piston Kit Part No.	Piston size (mm)	Over size (mm)	Ring Set Part No.
8567DA	89,94	Std.	900XS	8648DA	95,95	Std.	960ADS-2	8670DA	95,95	Std.	960ADS-2
8567DB	89,95	+0,01	900XS	8648DB	95,96	+0,01	960ADS-2	8670DB	95,96	+0,01	960ADS-2
8567DC	89,96	+0,02	900XS	8648DC	95,97	+0,02	960ADS-2	8670DC	95,97	+0,02	960ADS-2
8567D550	95,44	+5,50	955XS	8648D200	97,95	+2,00	980ADS-2				

	set includes		
Clip Part No.	CW20	CW19	CW19
Pin Part No.	WP029	WP037	WP037
Rings	included	included	included
Price-Code	7	7	7
Stroke	62.6	62.1	62.1
Wössner/ OEM Comp. ratio	13.5:1 12.2:1	12:1 12:1	13:1 12:1
Dome Volume (CC)	+0.5 cm <sup>3</sup>	+0.2 cm <sup>3</sup>	+5.6 cm <sup>3</sup>
Comp. Height (mm)	25.30	23.60	23.60

	extra parts		
Top End Gasket Kit	D4023-EST	D4015-EST	D4015-EST
Wössner Connecting rods	P4009	P4010 `06-08	P4010 `06-08
Needle bearing	-	-	-
Main bearing	-	-	-

## Kawasaki® - 4 stroke



Verdichtungen beziehen sich auf Standardmaße „-DA“  
 Compression ratio refer to standard sizes “-DA”



Model	KX450F	KX450F Pro Series	KX450F
Years	09-12	09-12	13-14
Displ. (cc)	449	449	449

Piston Kit Part No.	Piston size (mm)	Over size (mm)	Ring Set Part No.	Piston Kit Part No.	Piston size (mm)	Over size (mm)	Ring Set Part No.	Piston Kit Part No.	Piston size (mm)	Over size (mm)	Ring Set Part No.
8738DA	95,96	Std.	960ADS-2	8769DA	95,96	Std.	960ADS-2	8890DA	95,96	Std.	960ADS-2
8738DB	95,97	+0,01	960ADS-2	8769DB	95,97	+0,01	960ADS-2	8890DB	95,97	+0,01	960ADS-2
8738DC	95,98	+0,02	960ADS-2	8769DC	95,98	+0,02	960ADS-2	8890DC	95,98	+0,02	960ADS-2

set includes			
Clip Part No.	CW19	CW19	CW19
Pin Part No.	WP071	WP071	WP071
Rings	included	included	included
Price-Code	7	7	7
Stroke	62.1	62.1	62.1
Wössner/ OEM Comp. ratio	12.5:1 12.5:1	13.5:1 12.5:1	12.5:1 12.5:1
Dome Volume (CC)	+1 cm <sup>3</sup>	+4.2 cm <sup>3</sup>	+1 cm <sup>3</sup>
Comp. Height (mm)	23.7	23.7	23.7

extra parts			
Top End Gasket Kit	D4016-EST	D4016-EST	-
Wössner Connecting rods	P4020 `09-14	P4020 `09-14	P4020 `09-14
Needle bearing	-	-	-
Main bearing	-	-	-



## Kawasaki® - 4 stroke



Verdichtungen beziehen sich auf Standardmaße „-DA“

Compression ratio refer to standard sizes “-DA”

Model	KX450F Pro Series <b>New!</b>	KLR600	KLX650 / KLX650R
Years	13-14	84-85	93-96 / 93-96
Displ. (cc)	449	564	651

Piston Kit Part No.	Piston size (mm)	Over size (mm)	Ring Set Part No.	Piston Kit Part No.	Piston size (mm)	Over size (mm)	Ring Set Part No.	Piston Kit Part No.	Piston size (mm)	Over size (mm)	Ring Set Part No.
8891DA	95,96	Std.	960ADS-2	8509D100	96,94	+1,00	970XSY	8512DA	99,94	Std.	1000XSY
8891DB	95,97	+0,01	960ADS-2	8509D150	97,44	+1,50	975XSY	8512DB	99,95	+0,01	1000XSY
8891DC	95,98	+0,02	960ADS-2	8509D200	97,94	+2,00	980XSY	8512DC	99,96	+0,02	1000XSY
								8512D100	100,94	+1,00	1010XSY
								8512D200	101,94	+2,00	1020XSU

	set includes		
Clip Part No.	CW19	CW23	CW24
Pin Part No.	WP071	WP008	WP057
Rings	included	included	included
Price-Code	7	7	7/1
Stroke	62.1	78	83
Wössner/ OEM Comp. ratio	13.5:1 12.5:1	9.5:1	- 9.5:1
Dome Volume (CC)	+4.2 cm <sup>3</sup>	+15.3 cm <sup>3</sup>	-24.9 cm <sup>3</sup>
Comp. Height (mm)	23.7	31	29.50

	extra parts		
Top End Gasket Kit	-	D4055-EST '84 D4056-EST '85-86	-
Wössner Connecting rods	P4020 '09-14	-	-
Needle bearing	-	-	-
Main bearing	-	-	-

## Kawasaki® - 4 stroke



Verdichtungen beziehen sich auf Standardmaße „-DA“  
 Compression ratio refer to standard sizes “-DA”

Model	KLR650 Tengai
Years	87-07
Displ. (cc)	651

Piston Kit Part No.	Piston size (mm)	Over size (mm)	Ring Set Part No.
8523DA	99,94	Std.	1000XSY
8523DB	99,95	+0,01	1000XSY
8523DC	99,96	+0,02	1000XSY
8523D100	100,94	+1,00	1010XSY
8523D200	101,94	+2,00	1020XSU

set includes	
Clip Part No.	CW24
Pin Part No.	WP057
Rings	included
Price-Code	7/1
Stroke	83
Wössner/ OEM Comp. ratio	11:1 9.5:1
Dome Volume (CC)	+9.8 cm <sup>3</sup>
Comp. Height (mm)	31

extra parts	
Top End Gasket Kit	-
Wössner Connecting rods	-
Needle bearing	-
Main bearing	-



Jay Springsteen und Jimmy Felice waren die Gewinner der Sports Twins Class mit Wössner Kolben in Daytona, 2007

Jay Springsteen and Jimmy Felice winner at the Sports Twins Class with Wössner Pistons at Daytona, 2007

## KTM® - 2 stroke



Model	SX50	SX50	SX60
Years	01-08	09-14	97-99
Displ. (cc)	50	50	60

Piston Kit Part No.	Piston size (mm)	Over size (mm)	Ring Set Part No.	Piston Kit Part No.	Piston size (mm)	Over size (mm)	Ring Set Part No.	Piston Kit Part No.	Piston size (mm)	Over size (mm)	Ring Set Part No.
8225DA	39,46	Std.	RSB3950	8262DA	39,46	Std.	RSB3950	8240DA	43,45	Std.	RSB4350
8225DB	39,47	+0,01	RSB3950	8262DB	39,47	+0,01	RSB3950	8240DB	43,46	+0,01	RSB4350
8225DC	39,48	+0,02	RSB3950	8262DC	39,48	+0,02	RSB3950	8240DC	43,47	+0,02	RSB4350

set includes			
Clip Part No.	CW12	CW12	CW12
Pin Part No.	WP101	WP101	WP091
Rings	included	included	included
Price-Code	1	1	1
Stroke	40	40	40
Comp. Height (mm)	21.6	21.6	21.6

extra parts			
Top End Gasket Kit	-	-	D4019-EST
Wössner Connecting rods	P2053	P2053 '01-14	P2002
Needle bearing	-	-	N1037
Main bearing	2 x MB6203C3	2 x MB6203C3	2 x MB6304C3

## KTM® - 2 stroke



Model	SX65	SX65	SX85
Years	00-08	09-14	03-14
Displ. (cc)	63	63	84

Piston Kit Part No.	Piston size (mm)	Over size (mm)	Ring Set Part No.	Piston Kit Part No.	Piston size (mm)	Over size (mm)	Ring Set Part No.	Piston Kit Part No.	Piston size (mm)	Over size (mm)	Ring Set Part No.
8198DA	44,96	Std.	RSB4500	8241DA	44,96	Std.	RSB4500	8147DA	46,95	Std.	RSB4700
8198DB	44,97	+0,01	RSB4500	8241DB	44,97	+0,01	RSB4500	8147DB	46,96	+0,01	RSB4700
8198DC	44,98	+0,02	RSB4500	8241DC	44,98	+0,02	RSB4500	8147DC	46,97	+0,02	RSB4700
8198DD	44,99	+0,03	RSB4500	8241DD	44,99	+0,03	RSB4500				
8198DE	45,00	+0,04	RSB4500	8241DE	45,00	+0,04	RSB4500				

	set includes		
Clip Part No.	CW12	CW12	CW14
Pin Part No.	WP091	WP091	WP058
Rings	included	included	included
Price-Code	1	1	1
Stroke	40	40.8	48.95
Comp. Height (mm)	21.7	21.60	24

	extra parts		
Top End Gasket Kit	D2019-EST `98-01 D2020-EST `02-08	D2016-EST	D2017-EST `03-12
Wössner Connecting rods	P2054 `00-02 P2002 `03-08	P2055 `09-14	P2006 `03-12 P2065 `13-14
Needle bearing	N1037	N1037	N1006
Main bearing	2 x MB6304C3	2 x MB6304C3	2 x MB6304C3

## KTM® - 2 stroke



<b>Model</b>	<b>SX105 Single Ring</b> Will not fit 85cc over bore	<b>LC2</b>	<b>SX125</b>
<b>Years</b>	04-11	all	84-86
<b>Displ. (cc)</b>	104	124,8	125

Piston Kit Part No.	Piston size (mm)	Over size (mm)	Ring Set Part No.	Piston Kit Part No.	Piston size (mm)	Over size (mm)	Ring Set Part No.	Piston Kit Part No.	Piston size (mm)	Over size (mm)	Ring Set Part No.
8224DA	51,94	Std.	RSB5200	8002DA	55,94	Std.	RDB5600	8030DA	53,94	Std.	RSB5400
8224DB	51,95	+0,01	RSB5200	8002D025	56,19	+0,25	RDB5625	8030DB	53,95	+0,01	RSB5400
8224DC	51,96	+0,02	RSB5200	8002D050	56,44	+0,50	RDB5650	8030DC	53,96	+0,02	RSB5400
				8002D075	56,69	+0,75	RDB5675				
				8002D100	56,94	+1,00	RDB5700				
				8002D125	57,19	+1,25	RDB5725				
				8002D150	57,44	+1,50	RDB5750				
				8002D200	57,94	+2,00	RDB5800				
				8002D250	58,44	+2,50	RDB5850				
				8002D300	58,94	+3,00	RDB5900				
				8002D400	59,94	+4,00	RDB6000				
				8002D450	60,44	+4,50	RDB6050				
				8002D500	60,94	+5,00	RDB6100				

	set includes		
<b>Clip Part No.</b>	CW14	CW16	CW15
<b>Pin Part No.</b>	WP058	WP036	WP032
<b>Rings</b>	included	included	included
<b>Price-Code</b>	2/1	2	2/1
<b>Stroke</b>	49.0	50.7	54.5
<b>Comp. Height (mm)</b>	24	29.9	30

	extra parts		
<b>Top End Gasket Kit</b>	-	-	-
<b>Wössner Connecting rods</b>	P2006 `04-11	-	-
<b>Needle bearing</b>	N1006	-	-
<b>Main bearing</b>	2 x MB6304C3	-	-

## KTM® - 2 stroke



Model	GS125 / MX125	EGS125 / GS125 / SX125 / EXC125	EXC125
Years	87-93	94-97 / 98-00	01-14
Displ. (cc)	125	125	125

Piston Kit Part No.	Piston size (mm)	Over size (mm)	Ring Set Part No.	Piston Kit Part No.	Piston size (mm)	Over size (mm)	Ring Set Part No.	Piston Kit Part No.	Piston size (mm)	Over size (mm)	Ring Set Part No.
8011DA	54,19	Std.	RDB5425	8029DA	54,19	Std.	RSB5425	8174DA	53,95	Std.	RSV5400
8011DB	54,20	+0,01	RDB5425	8029DB	54,20	+0,01	RSB5425	8174DB	53,96	+0,01	RSV5400
8011DC	54,21	+0,02	RDB5425	8029DC	54,21	+0,02	RSB5425	8174DC	53,97	+0,02	RSV5400
8011DD	54,22	+0,03	RDB5425	8029D050	54,69	+0,50	RSB5475	8174DD	53,98	+0,03	RSV5400
8011D050	54,69	+0,50	RDB5475	8029D200	56,19	+2,00	RSB5625	8174D050	54,45	+0,50	RDB5450
								8174D100	54,95	+1,00	RDB5500

set includes			
Clip Part No.	CW15	CW15	CW15
Pin Part No.	WP032	WP032	WP032
Rings	included	included	included
Price-Code	2	2	2
Stroke	54.1	54.1	54.5
Comp. Height (mm)	28	28	29.5

extra parts			
Top End Gasket Kit	-	D2018-EST	D2018-EST `98-01 D2043-EST `02-13
Wössner Connecting rods	P2056	P2056 `89-97 P2011 `98-06	P2011 `98-06 P2012 `07-14
Needle bearing	-	-	N1010
Main bearing	-	-	1 x MBNJ206 Left 1 x MB63052RS Right

## KTM® - 2 stroke



Model	SX125 Single Ring	SX125 Single Ring	SX144 Single Ring
Years	01-06	07-14	07-08
Displ. (cc)	125	125	144

Piston Kit Part No.	Piston size (mm)	Over size (mm)	Ring Set Part No.	Piston Kit Part No.	Piston size (mm)	Over size (mm)	Ring Set Part No.	Piston Kit Part No.	Piston size (mm)	Over size (mm)	Ring Set Part No.
8056DA	53,95	Std.	RSV5400	8220DA	53,95	Std.	RSV5400	8222DA	55,95	Std.	RSB5600
8056DB	53,96	+0,01	RSV5400	8220DB	53,96	+0,01	RSV5400	8222DB	55,96	+0,01	RSB5600
8056DC	53,97	+0,02	RSV5400	8220DC	53,97	+0,02	RSV5400	8222DC	55,97	+0,02	RSB5600
8056D200	55,95	+2,00	RSB5600	8220D200	55,95	+2,00	RSB5600				
				8220D400	57,95	+4,00	RSB5800				

	set includes		
Clip Part No.	CW15	CW15	CW15
Pin Part No.	WP032	WP032	WP032
Rings	included	included	included
Price-Code	2	2	2
Stroke	54.5	54.5	58.5
Comp. Height (mm)	29.5	29.5	29.5

	extra parts		
Top End Gasket Kit	D2043-EST `02-13	D2043-EST `02-13	-
Wössner Connecting rods	P2011 `98-06	P2012 `07-14	P2012
Needle bearing	N1010	N1010	N1010
Main bearing	1 x MBNJ206 Left 1 x MB63052RS Right	1 x MBNJ206 Left 1 x MB63052RS Right	1 x MBNJ206 Left 1 x MB63052RS Right

## KTM® - 2 stroke



**New!**

Model	SX150 Single Ring	175GS/MC	EXC200 / SX200
Years	09-14	77-82	98-14 / 03-05
Displ. (cc)	144	171	200

Piston Kit Part No.	Piston size (mm)	Over size (mm)	Ring Set Part No.	Piston Kit Part No.	Piston size (mm)	Over size (mm)	Ring Set Part No.	Piston Kit Part No.	Piston size (mm)	Over size (mm)	Ring Set Part No.
8222DA	55,95	Std.	RSB5600	8292DA	63,44	Std.	RSB6350	8048DA	63,94	Std.	RDB6400
8222DB	55,96	+0,01	RSB5600	8292D050	63,94	+0,50	RSB6400	8048DB	63,95	+0,01	RDB6400
8222DC	55,97	+0,02	RSB5600	8292D100	64,44	+1,00	RSB6450	8048DC	63,96	+0,02	RDB6400
				8292D150	64,94	+1,50	RSB6500				
				8292D200	65,44	+2,00	RSB6550				

	set includes		
Clip Part No.	CW15	CW15	CW16
Pin Part No.	WP032	WP011	WP027
Rings	included	included	included
Price-Code	2	3	3
Stroke	58.5	54	60
Comp. Height (mm)	29.5	37	28

	extra parts		
Top End Gasket Kit	-	-	D2023-EST `99-03 D2022-EST `02-09
Wössner Connecting rods	P2012 `09-14	-	P2031 `98-14
Needle bearing	N1010	-	N1013
Main bearing	1 x MBNJ206 Left 1 x MB63052RS Right	-	1 x MBNJ206 Left `98-12 1 x MB63052RS Right `98-12



## KTM® - 2 stroke



Model	EXC250	MX250 / MXC250 / GS240 / GS250	GS240 / GS250
Years	77-82	84	85-88
Displ. (cc)	249	249	249

Piston Kit Part No.	Piston size (mm)	Over size (mm)	Ring Set Part No.	Piston Kit Part No.	Piston size (mm)	Over size (mm)	Ring Set Part No.	Piston Kit Part No.	Piston size (mm)	Over size (mm)	Ring Set Part No.
8034D150	72,43	+1,50	RSB7250	8050D100	71,93	+1,00	RSB7200	8025DA	66,44	Std.	RSB6650
8034D200	72,93	+2,00	RSB7300	8050D150	72,43	+1,50	RSB7250	8025D050	66,94	+0,50	RSB6700
				8050D200	72,93	+2,00	RSB7300	8025D100	67,44	+1,00	RSB6750
								8025D150	67,94	+1,50	RSB6800

	set includes		
Clip Part No.	CW18	CW18	CW18
Pin Part No.	WP033	WP033	WP033
Rings	included	included	included
Price-Code	3/1	3/1	3
Stroke	60.4	61.3	71.7
Comp. Height (mm)	38	30	29,7

	extra parts		
Top End Gasket Kit	-	-	-
Wössner Connecting rods	-	-	-
Needle bearing	-	-	-
Main bearing	-	-	-

## KTM® - 2 stroke



Model	GS250 / SX250	SX250	MXC250 / EXC250 / SX250
Years	90-94	95	96-99
Displ. (cc)	249	249	249

Piston Kit Part No.	Piston size (mm)	Over size (mm)	Ring Set Part No.	Piston Kit Part No.	Piston size (mm)	Over size (mm)	Ring Set Part No.	Piston Kit Part No.	Piston size (mm)	Over size (mm)	Ring Set Part No.
8005DA	67,44	Std.	RDB6750	8014DA	67,44	Std.	RDB6750	8016DA	67,44	Std.	RDB6750
8005DB	67,45	+0,01	RDB6750	8014DB	67,45	+0,01	RDB6750	8016DB	67,45	+0,01	RDB6750
8005DC	67,46	+0,02	RDB6750	8014DC	67,46	+0,02	RDB6750	8016DC	67,46	+0,02	RDB6750
8005D050	67,94	+0,50	RDB6800	8014D050	67,94	+0,50	RDB6800	8016D050	67,94	+0,50	RDB6800
8005D100	68,44	+1,00	RDB6850					8016D100	68,44	+1,00	RDB6850

	set includes		
Clip Part No.	CW18	CW18	CW18
Pin Part No.	WP033	WP033	WP033
Rings	included	included	included
Price-Code	3	3/1	3
Stroke	69.5	69.5	69.5
Comp. Height (mm)	29,70	29.70	26.70

	extra parts		
Top End Gasket Kit	D2078-EST	D2078-EST	D2078-EST
Wössner Connecting rods	P2024	P2024	P2024
Needle bearing	N1020	N1020	N1020
Main bearing	-	-	-

## KTM® - 2 stroke



Model	MXC / EXC250	SX250	SX250 / EXC250 Single Ring
Years	00-05	00-02	03-04 / 06-14
Displ. (cc)	249	249	249

Piston Kit Part No.	Piston size (mm)	Over size (mm)	Ring Set Part No.	Piston Kit Part No.	Piston size (mm)	Over size (mm)	Ring Set Part No.	Piston Kit Part No.	Piston size (mm)	Over size (mm)	Ring Set Part No.
8081DA	66,34	Std.	RDB6640	8090DA	66,34	Std.	RSB6640	8082DA	66,34	Std.	RSB6640
8081DB	66,35	+0,01	RDB6640	8090DB	66,35	+0,01	RSB6640	8082DB	66,35	+0,01	RSB6640
8081DC	66,36	+0,02	RDB6640	8090DC	66,36	+0,02	RSB6640	8082DC	66,36	+0,02	RSB6640
				8090D060	66,94	+0,60	RSB6700				

	set includes		
Clip Part No.	CW18	CW18	CW18
Pin Part No.	WP033	WP033	WP033
Rings	included	included	included
Price-Code	3	3/1	3
Stroke	72	72	72
Comp. Height (mm)	38	38	38

	extra parts		
Top End Gasket Kit	-	-	D2024-EST
Wössner Connecting rods	P2058 `00-03 P2023 `04-13	P2058	P2023 `04-14
Needle bearing	N1020	N1020	N1020
Main bearing	2 x MBNJ206C3	-	2 x MBNJ206C3

## KTM® - 2 stroke



Model	SX250 / EXC250 Double Ring	GS300 / MX300 / EXC300	GS300 / SX300
Years	05-14 / 06-13	90-94	95
Displ. (cc)	249	297	297

Piston Kit Part No.	Piston size (mm)	Over size (mm)	Ring Set Part No.	Piston Kit Part No.	Piston size (mm)	Over size (mm)	Ring Set Part No.	Piston Kit Part No.	Piston size (mm)	Over size (mm)	Ring Set Part No.
8169DA	66,34	Std.	RDB6640	8012DA	71,93	Std.	RDB7200	8042DA	71,93	Std.	RDB7200
8169DB	66,35	+0,01	RDB6640	8012DB	71,94	+0,01	RDB7200	8042DB	71,94	+0,01	RDB7200
8169DC	66,36	+0,02	RDB6640	8012DC	71,95	+0,02	RDB7200	8042DC	71,95	+0,02	RDB7200
				8012D050	72,43	+0,50	RDB7250				
				8012D100	72,93	+1,00	RDB7300				

	set includes		
Clip Part No.	CW18	CW18	CW18
Pin Part No.	WP033	WP039	WP033
Rings	included	included	included
Price-Code	3	6	6
Stroke	72	72	72
Comp. Height (mm)	38	29.7	29.7

	extra parts		
Top End Gasket Kit	D2024-EST `04-06 D2025-EST `07-12	D2078-EST	D2078-EST
Wössner Connecting rods	P2023 `04-14	P2024	P2024
Needle bearing	N1020	N1020	N1020
Main bearing	2 x MBNJ206C3	-	-

## KTM® - 2 stroke



Model	EGS300 / EXC300	EXC300 / MXC300 / XC / XC-W	EXC300 / MXC300
Years	96-03	04-07	08-14
Displ. (cc)	297	293	293

Piston Kit Part No.	Piston size (mm)	Over size (mm)	Ring Set Part No.	Piston Kit Part No.	Piston size (mm)	Over size (mm)	Ring Set Part No.	Piston Kit Part No.	Piston size (mm)	Over size (mm)	Ring Set Part No.
8017DA	71,93	Std.	RDB7200	8219DA	71,94	Std.	RDB7200	8250DA	71,94	Std.	RDB7200
8017DB	71,94	+0,01	RDB7200	8219DB	71,95	+0,01	RDB7200	8250DB	71,95	+0,01	RDB7200
8017DC	71,95	+0,02	RDB7200	8219DC	71,96	+0,02	RDB7200	8250DC	71,96	+0,02	RDB7200
8017D050	72,43	+0,50	RDB7250								
8017D100	72,93	+1,00	RDB7300								

	set includes		
Clip Part No.	CW18	CW18	CW18
Pin Part No.	WP033	WP033	WP033
Rings	included	included	included
Price-Code	6	6	6
Stroke	72	72	72
Comp. Height (mm)	26.70	38	38

	extra parts		
Top End Gasket Kit	D2078-EST	-	D2025-EST
Wössner Connecting rods	P2024 `90-03	P2023	P2023 `04-14
Needle bearing	N1020	N1020	N1020
Main bearing	-	-	-

## KTM® - 2 stroke



<b>Model</b>	EGS / EXC / SX360	EGS380 / EXC380 / SX380
<b>Years</b>	96-97	98-02
<b>Displ. (cc)</b>	353	368

Piston Kit Part No.	Piston size (mm)	Over size (mm)	Ring Set Part No.	Piston Kit Part No.	Piston size (mm)	Over size (mm)	Ring Set Part No.
8083DA	77,94	Std.	RSC7800	8223DA	77,94	Std.	RSC7800
8083DB	77,95	+0,01	RSC7800	8223DB	77,95	+0,01	RSC7800
8083DC	77,96	+0,02	RSC7800	8223DC	77,96	+0,02	RSC7800
8083D050	78,44	+0,50	RSC7850	8223D050	78,44	+0,50	RSC7850
8083D100	78,94	+1,00	RSC7900				

set includes		
<b>Clip Part No.</b>	CA18	CA18
<b>Pin Part No.</b>	WP039	WP039
<b>Rings</b>	included	included
<b>Price-Code</b>	6	6
<b>Stroke</b>	74	77
<b>Comp. Height (mm)</b>	27	27

extra parts		
<b>Top End Gasket Kit</b>	D2077-EST	D2077-EST
<b>Wössner Connecting rods</b>	-	-
<b>Needle bearing</b>	N1020	N1020
<b>Main bearing</b>	-	-

## KTM® - 4 stroke



Verdichtungen beziehen sich auf Standardmaße „-DA“  
 Compression ratio refer to standard sizes “-DA”

**New!**

Model	EXC250 Racing	EXC250 Racing	EXC250F
Years	01-06	06-14	2014
Displ. (cc)	249	249	249

Piston Kit Part No.	Piston size (mm)	Over size (mm)	Ring Set Part No.	Piston Kit Part No.	Piston size (mm)	Over size (mm)	Ring Set Part No.	Piston Kit Part No.	Piston size (mm)	Over size (mm)	Ring Set Part No.
8592DA	74,95	Std.	750XDS	8645DA	75,96	Std.	760XAS	8865DA	77,96	Std.	König Ø 78-4T
8592DB	74,96	+0,01	750XDS	8645DB	75,97	+0,01	760XAS	8865DB	77,97	+0,01	König Ø 78-4T
8592DC	74,97	+0,02	750XDS	8645DC	75,98	+0,02	760XAS	8865DC	77,98	+0,02	König Ø 78-4T
				8645D400	79,96	+4,00	800XDS				

	set includes		
Clip Part No.	CW20	CW16	CW16
Pin Part No.	WP029	WP070 = DA-DC / WP059 = D400	WP070
Rings	included	included	included
Price-Code	5/1	5/1	5/2
Stroke	56.5	54.8	52.3
Wössner/ OEM Comp. ratio	- 12:1	12.9:1 12.8:1	13.9:1 13.9:1
Dome Volume (CC)	+4.1 cm <sup>3</sup>	DA - DC = -1.2 cm <sup>3</sup> D400 = -3.7 cm <sup>3</sup>	-2.1 cm <sup>3</sup>
Comp. Height (mm)	25.30	19.50	19.50

	extra parts		
Top End Gasket Kit	-	-	-
Wössner Connecting rods	P4048	P4003	P4059
Needle bearing	-	-	-
Main bearing	2 x MBNJ206	-	-

## KTM® - 4 stroke

Verdichtungen beziehen sich auf Standardmaße „-DA“

Compression ratio refer to standard sizes “-DA”

<b>Model</b>	EXC250F Pro Series <b>New!</b>	SX-F 250
<b>Years</b>	2014	06-12
<b>Displ. (cc)</b>	249	249

Piston Kit Part No.	Piston size (mm)	Over size (mm)	Ring Set Part No.	Piston Kit Part No.	Piston size (mm)	Over size (mm)	Ring Set Part No.
8874DA	77,96	Std.	König Ø 78-4T	8645DA	75,96	Std.	760XAS
8874DB	77,97	+0,01	König Ø 78-4T	8645DB	75,97	+0,01	760XAS
8874DC	77,98	+0,02	König Ø 78-4T	8645DC	75,98	+0,02	760XAS
				8645D400	79,96	+4,00	800XDS

set includes		
<b>Clip Part No.</b>	CW16	CW16
<b>Pin Part No.</b>	WP070	WP070 = DA-DC / WP059 = D400
<b>Rings</b>	included	included
<b>Price-Code</b>	5/2	5/1
<b>Stroke</b>	52.3	54.8
<b>Wössner/ OEM Comp. ratio</b>	14.5:1 13.9:1	12.9:1 12.8:1
<b>Dome Volume (CC)</b>	-1.2 cm <sup>3</sup>	DA - DC = -1.2 cm <sup>3</sup> D400 = -3.7 cm <sup>3</sup>
<b>Comp. Height (mm)</b>	19.50	19.50

extra parts		
<b>Top End Gasket Kit</b>	-	D4018-EST
<b>Wössner Connecting rods</b>	P4059	P4003
<b>Needle bearing</b>	-	-
<b>Main bearing</b>	-	2 x MBNJ206C3



## KTM® - 4 stroke



Verdichtungen beziehen sich auf Standardmaße „-DA“

Compression ratio refer to standard sizes “-DA”

Model	SX-F250 Pro-Series	SX-F250	SX-F250 Pro Series
Years	06-12	13-14	13-14
Displ. (cc)	249	249,91	249,91

Piston Kit Part No.	Piston size (mm)	Over size (mm)	Ring Set Part No.	Piston Kit Part No.	Piston size (mm)	Over size (mm)	Ring Set Part No.	Piston Kit Part No.	Piston size (mm)	Over size (mm)	Ring Set Part No.
8690DA	75,96	Std.	760XAS	8865DA	77,96	Std.	KönigØ78-4T	8874DA	77,96	Std.	KönigØ78-4T
8690DB	75,97	+0,01	760XAS	8865DB	77,97	+0,01	KönigØ78-4T	8874DB	77,97	+0,01	KönigØ78-4T
8690DC	75,98	+0,02	760XAS	8865DC	77,98	+0,02	KönigØ78-4T	8874DC	77,98	+0,02	KönigØ78-4T
8690D400	79,96	+4,00	800XDS								

	set includes		
Clip Part No.	CW16	CW16	CW16
Pin Part No.	WP059	WP070	WP070
Rings	included	included	included
Price-Code	5/1	5/2	5/2
Stroke	54.8	52.3	52.3
Wössner/ OEM Comp. ratio	14.4:1 12.8:1	13.9:1 13.9:1	14.5:1 13.9:1
Dome Volume (CC)	+2.3 cm <sup>3</sup>	-2.1 cm <sup>3</sup>	-1.2 cm <sup>3</sup>
Comp. Height (mm)	19.50	19.5	19.5

	extra parts		
Top End Gasket Kit	D4018-EST	-	-
Wössner Connecting rods	P4003	P4059 `13-14	P4059 `13-14
Needle bearing	-	-	-
Main bearing	2 x MBNJ206C3	-	-

## KTM® - 4 stroke



Verdichtungen beziehen sich auf Standardmaße „-DA“  
 Compression ratio refer to standard sizes “-DA”

**New!**

Model	SX-F350	SX-F350 Pro Series	EXC-F350
Years	10-14	10-14	13
Displ. (cc)	349,7	349,7	349,7

Piston Kit Part No.	Piston size (mm)	Over size (mm)	Ring Set Part No.	Piston Kit Part No.	Piston size (mm)	Over size (mm)	Ring Set Part No.	Piston Kit Part No.	Piston size (mm)	Over size (mm)	Ring Set Part No.
8807DA	87,95	Std.	880XS	8810DA	87,95	Std.	880XS	8885DA	87,95	Std.	880XS
8807DB	87,96	+0,01	880XS	8810DB	87,96	+0,01	880XS	8885DB	87,96	+0,01	880XS
8807DC	87,97	+0,02	880XS	8810DC	87,97	+0,02	880XS	8885DC	87,97	+0,02	880XS
8807D200	89,95	+2,00	900XS	8810D200	89,95	+2,00	900XS				
8807D300	90,95	+3,00	910XS								

	set includes		
Clip Part No.	CW18	CW18	CW18
Pin Part No.	WP053	WP099	WP054
Rings	included	included	included
Price-Code	7	7	7
Stroke	57.5	57.5	57.5
Wössner/ OEM Comp. ratio	13.5:1 13.5:1	14.5:1 13.5:1	- 12.3:1
Dome Volume (CC)	+1.25 cm <sup>3</sup>	+3.3 cm <sup>3</sup> / +2.1 cm <sup>3</sup>	-0.1 cm <sup>3</sup>
Comp. Height (mm)	20.5	20.5	20.5

	extra parts		
Top End Gasket Kit	-	-	-
Wössner Connecting rods	P4040 `10-13	P4040 `10-13	P4061 `13-14
Needle bearing	-	-	-
Main bearing	-	-	-

## KTM® - 4 stroke



Verdichtungen beziehen sich auf Standardmaße „-DA“

Compression ratio refer to standard sizes “-DA”

Model	350LC4	400LC4	400LC4 / ESG-E
Years	92-94	93-96	97
Displ. (cc)	349	400	398

Piston Kit Part No.	Piston size (mm)	Over size (mm)	Ring Set Part No.	Piston Kit Part No.	Piston size (mm)	Over size (mm)	Ring Set Part No.	Piston Kit Part No.	Piston size (mm)	Over size (mm)	Ring Set Part No.
8506DA	88,94	Std.	890XSY	8520DA	94,94	Std.	950XSY	8506DA	88,94	Std.	890XSY
8506DB	88,95	+0,01	890XSY	8520DB	94,95	+0,01	950XSY	8506DB	88,95	+0,01	890XSY
8506DC	88,96	+0,02	890XSY	8520DC	94,96	+0,02	950XSY	8506DC	88,96	+0,02	890XSY

	set includes		
Clip Part No.	CW22	CW22	CW22
Pin Part No.	WP017	WP009	WP017
Rings	included	included	included
Price-Code	7/1	7/1	7/1
Stroke	64	56.5	64
Wössner/ OEM Comp. ratio	- 10.0:1	- 10.8:1	- 10:1
Dome Volume (CC)	+13.6 cm <sup>3</sup>	+6.4 cm <sup>3</sup>	+13.6 cm <sup>3</sup>
Comp. Height (mm)	26.50	26.50	26.50

	extra parts		
Top End Gasket Kit	-	-	-
Wössner Connecting rods	-	-	-
Needle bearing	-	-	-
Main bearing	-	-	-

## KTM® - 4 stroke



Verdichtungen beziehen sich auf Standardmaße „-DA“  
 Compression ratio refer to standard sizes “-DA”

Model	400LC4	400LC4 Pro Series	EXC400
Years	98-01	98-01	09-12
Displ. (cc)	398	398	398

Piston Kit Part No.	Piston size (mm)	Over size (mm)	Ring Set Part No.	Piston Kit Part No.	Piston size (mm)	Over size (mm)	Ring Set Part No.	Piston Kit Part No.	Piston size (mm)	Over size (mm)	Ring Set Part No.
8580DA	88,94	Std.	890XSY	8636DA	88,94	Std.	890XSY	8806DA	94,95	Std.	950ADS-2
8580DB	88,95	+0,01	890XSY	8636DB	88,95	+0,01	890XSY	8806DB	94,96	+0,01	950ADS-2
8580DC	88,96	+0,02	890XSY	8636DC	88,96	+0,02	890XSY	8806DC	94,97	+0,02	950ADS-2
				8636D200	90,94	+2,00	910XSY				

	set includes		
Clip Part No.	CW20	CW20	CW19
Pin Part No.	WP038	WP038	WP071
Rings	included	included	included
Price-Code	7/1	7/1	7/1
Stroke	64	64	55.5
Wössner/ OEM Comp. ratio	- 11:1	12.5:1 11:1	11.1:1 11.1:1
Dome Volume (CC)	+7.0 cm <sup>3</sup>	+12.2 cm <sup>3</sup>	-0.2 cm <sup>3</sup>
Comp. Height (mm)	27.50	27.50	22.8

	extra parts		
Top End Gasket Kit	-	-	-
Wössner Connecting rods	P4014	-	-
Needle bearing	-	-	-
Main bearing	MBNJ207RC3 Left `97-12 MBNJ306C3 Right `98-01	MBNJ207RC3 Left `97-12 MBNJ306C3 Right `98-01	-

## KTM® - 4 stroke



Verdichtungen beziehen sich auf Standardmaße „-DA“  
 Compression ratio refer to standard sizes “-DA”

**New!**

Model	EXC450 Racing	EXC450R	EXC450
Years	03-07	08-11	12-14
Displ. (cc)	449	449	449

Piston Kit Part No.	Piston size (mm)	Over size (mm)	Ring Set Part No.	Piston Kit Part No.	Piston size (mm)	Over size (mm)	Ring Set Part No.	Piston Kit Part No.	Piston size (mm)	Over size (mm)	Ring Set Part No.
8581DA	88,96	Std.	890XSX	8707DA	94,95	Std.	950ADS-2	8898DA	94,95	Std.	950ADS-2
8581DB	88,97	+0,01	890XSX	8707DB	94,96	+0,01	950ADS-2	8898DB	94,96	+0,01	950ADS-2
8581DC	88,98	+0,02	890XSX	8707DC	94,97	+0,02	950ADS-2	8898DC	94,97	+0,02	950ADS-2

set includes			
Clip Part No.	CW20	CW19	CW19
Pin Part No.	WP038	WP037	WP071
Rings	included	included	included
Price-Code	7	7	7
Stroke	72	63.4	63.4
Wössner/ OEM Comp. ratio	11.1:1 11.1:1	- 11.9:1	- 11.8:1
Dome Volume (CC)	-7.1 cm <sup>3</sup>	-1.9 cm <sup>3</sup>	-1.6 cm <sup>3</sup>
Comp. Height (mm)	23.50	22.80	22.80

extra parts			
Top End Gasket Kit	-	D4033-EST	-
Wössner Connecting rods	P4048	P4016	P4057 `12-14
Needle bearing	-	-	-
Main bearing	2 x MBNJ206C3	-	-

## KTM® - 4 stroke



Verdichtungen beziehen sich auf Standardmaße „-DA“

Compression ratio refer to standard sizes “-DA”

Model	SX450 Racing	SX450 Racing Pro Series	SX-F450
Years	03-06	03-06	07-12
Displ. (cc)	449	449	449

Piston Kit Part No.	Piston size (mm)	Over size (mm)	Ring Set Part No.	Piston Kit Part No.	Piston size (mm)	Over size (mm)	Ring Set Part No.	Piston Kit Part No.	Piston size (mm)	Over size (mm)	Ring Set Part No.
8560DA	94,96	Std.	950ADS-2	8571DA	94,96	Std.	950ADS-2	8665DA	96,96	Std.	970ADS-2
8560DB	94,97	+0,01	950ADS-2	8571DB	94,97	+0,01	950ADS-2	8665DB	96,97	+0,01	970ADS-2
8560DC	94,98	+0,02	950ADS-2	8571DC	94,98	+0,02	950ADS-2	8665DC	96,98	+0,02	970ADS-2
8560D200	96,96	+2,00	970ADS-2	8571D200	96,96	+2,00	970ADS-2				

	set includes		
Clip Part No.	CW20	CW20	CW19
Pin Part No.	WP038	WP038	WP037
Rings	included	included	included
Price-Code	7	7	7
Stroke	63.4	63.4	60.8
Wössner/ OEM Comp. ratio	- 12:1	- 12:1	12.5:1 12.5:1
Dome Volume (CC)	+5.8 cm <sup>3</sup>	+11.5 cm <sup>3</sup>	-2.6 cm <sup>3</sup>
Comp. Height (mm)	21.60	21.60	21.30

	extra parts		
Top End Gasket Kit	D4020-EST	D4020-EST	D4019-EST
Wössner Connecting rods	P4015 `03-06	P4015 `03-06	P4017
Needle bearing	-	-	-
Main bearing	-	-	-

## KTM® - 4 stroke



Verdichtungen beziehen sich auf Standardmaße „-DA“

Compression ratio refer to standard sizes “-DA”

Model	SX-F450 Pro Series	SX-F450	SX-F450 Pro Series
Years	07-12	13-14	13-14
Displ. (cc)	449	449,3	449,3

Piston Kit Part No.	Piston size (mm)	Over size (mm)	Ring Set Part No.	Piston Kit Part No.	Piston size (mm)	Over size (mm)	Ring Set Part No.	Piston Kit Part No.	Piston size (mm)	Over size (mm)	Ring Set Part No.
8715DA	96,96	Std.	970ADS-2	8868DA	94,95	Std.	950ADS-2	8873DA	94,95	Std.	950ADS-2
8715DB	96,97	+0,01	970ADS-2	8868DB	94,96	+0,01	950ADS-2	8873DB	94,96	+0,01	950ADS-2
8715DC	96,98	+0,02	970ADS-2	8868DC	94,97	+0,02	950ADS-2	8873DC	94,97	+0,02	950ADS-2

	set includes		
Clip Part No.	CW19	CW19	CW19
Pin Part No.	WP071	WP071	WP071
Rings	included	included	included
Price-Code	7/1	7/1	7/1
Stroke	60.8	63.4	63.4
Wössner/ OEM Comp. ratio	13.5:1 12.5:1	12.6:1 12.6:1	13.6:1 12.6:1
Dome Volume (CC)	+1.1 cm <sup>3</sup>	+1 cm <sup>3</sup>	+4.05 cm <sup>3</sup>
Comp. Height (mm)	21.30	22.8	22.8

	extra parts		
Top End Gasket Kit	D4019-EST	D4061-EST `13	D4061-EST
Wössner Connecting rods	P4017	P4058 `13-14	P4058 `13-14
Needle bearing	-	-	-
Main bearing	-	-	-

## KTM® - 4 stroke



Verdichtungen beziehen sich auf Standardmaße „-DA“

Compression ratio refer to standard sizes “-DA”

Model	SX-F505	SX-F505 Pro Series	EXC500
Years	07-08	07-08	12-14
Displ. (cc)	477	449	510,4

Piston Kit Part No.	Piston size (mm)	Over size (mm)	Ring Set Part No.	Piston Kit Part No.	Piston size (mm)	Over size (mm)	Ring Set Part No.	Piston Kit Part No.	Piston size (mm)	Over size (mm)	Ring Set Part No.
8705DA	99,95	Std.	1000ADS-2	8725DA	99,95	Std.	1000ADS-2	8821DA	94,95	Std.	950ADS-2
8705DB	99,96	+0,01	1000ADS-2	8725DB	99,96	+0,01	1000ADS-2	8821DB	94,96	+0,01	950ADS-2
8705DC	99,97	+0,02	1000ADS-2	8725DC	99,97	+0,02	1000ADS-2	8821DC	94,97	+0,02	950ADS-2

	set includes		
Clip Part No.	CW20	CW20	CW19
Pin Part No.	WP073	WP038	-
Rings	included	included	included
Price-Code	7/1	7/1	7
Stroke	60.8	60.8	72
Wössner/ OEM Comp. ratio	12.5:1 12.5:1	13.5:1 12.5:1	11.8:1 11.8:1
Dome Volume (CC)	-3.0 cm <sup>3</sup>	+0.3 cm <sup>3</sup>	-6.8 cm <sup>3</sup>
Comp. Height (mm)	21.40	21.80	22.8

	extra parts		
Top End Gasket Kit	-	-	-
Wössner Connecting rods	P4055 `08	P4055 `08	P4051 `12-13
Needle bearing	-	-	-
Main bearing	-	-	-



## KTM® - 4 stroke



Verdichtungen beziehen sich auf Standardmaße „-DA“

Compression ratio refer to standard sizes “-DA”

Model	SX-EXC520 / SX-EXC525 Racing	SX-EXC520 / SX-EXC525 Racing Pro Series	EXC530R Pro Series
Years	00-02 / 03-07	00-02 / 03-07	08-11
Displ. (cc)	510	510	510

Piston Kit Part No.	Piston size (mm)	Over size (mm)	Ring Set Part No.	Piston Kit Part No.	Piston size (mm)	Over size (mm)	Ring Set Part No.	Piston Kit Part No.	Piston size (mm)	Over size (mm)	Ring Set Part No.
8547DA	94,95	Std.	950ADS-2	8637DA	94,95	Std.	950ADS-2	8706DA	94,96	Std.	950ADS-2
8547DB	94,96	+0,01	950ADS-2	8637DB	94,96	+0,01	950ADS-2	8706DB	94,97	+0,01	950ADS-2
8547DC	94,97	+0,02	950ADS-2	8637DC	94,97	+0,02	950ADS-2	8706DC	94,98	+0,02	950ADS-2
8547D200	96,95	+2,00	970ADS-2	8637D200	96,95	+2,00	970ADS-2				
				8637D400	98,95	+4,00	990XSY				

	set includes		
Clip Part No.	CW20	CW20	CW19
Pin Part No.	WP073	WP029	WP037
Rings	included	included	included
Price-Code	7/1	7/1	7
Stroke	72	72	72
Wössner/ OEM Comp. ratio	11:1	12.5:1 11:1	12.5:1 11.9:1
Dome Volume (CC)	-2.1 cm <sup>3</sup>	+4.61 cm <sup>3</sup>	-2.8 cm <sup>3</sup>
Comp. Height (mm)	23.50	23.50	24.40

	extra parts		
Top End Gasket Kit	D4021-EST	D4021-EST	D4033-EST
Wössner Connecting rods	P4048	P4048	P4047
Needle bearing	-	-	-
Main bearing	2 x MBNJ206	2 x MBNJ206	-

## KTM® - 4 stroke



Verdichtungen beziehen sich auf Standardmaße „-DA“

Compression ratio refer to standard sizes “-DA”

Model	SXS540 Racing	SMR560 Pro Series	600LC4
Years	06	06-07	88-92
Displ. (cc)	535	600	553

Piston Kit Part No.	Piston size (mm)	Over size (mm)	Ring Set Part No.	Piston Kit Part No.	Piston size (mm)	Over size (mm)	Ring Set Part No.	Piston Kit Part No.	Piston size (mm)	Over size (mm)	Ring Set Part No.
8583DA	99,95	Std.	1000ADS-2	8704DA	99,95	Std.	1000ADS-2	8520DA	94,94	Std.	950XSY
8583DB	99,96	+0,01	1000ADS-2	8704DB	99,96	+0,01	1000ADS-2	8520DB	94,95	+0,01	950XSY
8583DC	99,97	+0,02	1000ADS-2	8704DC	99,97	+0,02	1000ADS-2	8520DC	94,96	+0,02	950XSY

	set includes		
Clip Part No.	CW20	CW20	CW22
Pin Part No.	WP038	WP038	WP009
Rings	included	included	included
Price-Code	7	7	7/1
Stroke	68	72	78
Wössner/ OEM Comp. ratio	- 12:1	12:1 11:1	- 10:1
Dome Volume (CC)	+0.8 cm <sup>3</sup>	+5.16 cm <sup>3</sup>	+6.4 cm <sup>3</sup>
Comp. Height (mm)	24.50	23,40	26.50

	extra parts		
Top End Gasket Kit	D4021-EST	-	-
Wössner Connecting rods	P4015	-	-
Needle bearing	-	-	-
Main bearing	-	2 x MBNJ206	-

## KTM® - 4 stroke



Verdichtungen beziehen sich auf Standardmaße „-DA“

Compression ratio refer to standard sizes “-DA”

Model	600LC4	620 / 625 / 640LC4 / SX / Duke / Supermoto	660SMC
Years	93	94-07	03-09
Displ. (cc)	600	600	660

Piston Kit Part No.	Piston size (mm)	Over size (mm)	Ring Set Part No.	Piston Kit Part No.	Piston size (mm)	Over size (mm)	Ring Set Part No.	Piston Kit Part No.	Piston size (mm)	Over size (mm)	Ring Set Part No.
8521DA	99,94	Std.	1000XSY	8524DA	100,94	Std.	1010XSY	8524D100	101,94	+1,00	1020XSK
8521DB	99,95	+0,01	1000XSY	8524DB	100,95	+0,01	1010XSY				
				8524DC	100,96	+0,02	1010XSY				
				8524D100	101,94	+1,00	1020XSK				

	set includes		
Clip Part No.	CW22	CW22	CW22
Pin Part No.	WP009	WP009	WP009
Rings	included	included	included
Price-Code	7/1	7/1	7/1
Stroke	81	76	76
Wössner/ OEM Comp. ratio	- 9.6:1	- 11.7:1	- 11.7:1
Dome Volume (CC)	+9.7 cm <sup>3</sup>	DA - DC = +7.6 cm <sup>3</sup> D100 = +8.0 cm <sup>3</sup>	+8.0 cm <sup>3</sup>
Comp. Height (mm)	26.50	26.50	26.50

	extra parts		
Top End Gasket Kit	-	D4034-EST	D4034-EST
Wössner Connecting rods	-	P4014 `03-07	P4014 `03-07
Needle bearing	-	-	-
Main bearing	-	-	-

## Maico® - 2 stroke



Model	MC250 GS250	MC250
Years	73-81	86-02
Displ. (cc)	245	247

Piston Kit Part No.	Piston size (mm)	Over size (mm)	Ring Set Part No.	Piston Kit Part No.	Piston size (mm)	Over size (mm)	Ring Set Part No.
8031DA	66,93	Std.	RSB6700	8045DA	66,93	Std.	RSB6700
8031D025	67,18	+0,25	RSB6725	8045D050	67,43	+0,50	RSB6750
8031D050	67,43	+0,50	RSB6750	8045D100	67,93	+1,00	RSB6800
8031D100	67,93	+1,00	RSB6800	8045D150	68,43	+1,50	RSB6850
8031D150	68,43	+1,50	RSB6850	8045D200	68,93	+2,00	RSB6900
8031D200	68,93	+2,00	RSB6900				

set includes		
Clip Part No.	CW18	CW18
Pin Part No.	WP033	WP033
Rings	included	included
Price-Code	3/1	3/1
Stroke	70	70
Comp. Height (mm)	41.70	35.70

extra parts		
Top End Gasket Kit	D2064-EST `78 D2065-EST `81	D2067-EST `83 D2092-EST `84-87
Wössner Connecting rods	-	-
Needle bearing	-	-
Main bearing	-	-

## Maico® - 2 stroke



Model	GS400	MC440 MD440	MC490 GS490
Years	73-81	73-81	80-02
Displ. (cc)	386	438	488

Piston Kit Part No.	Piston size (mm)	Over size (mm)	Ring Set Part No.	Piston Kit Part No.	Piston size (mm)	Over size (mm)	Ring Set Part No.	Piston Kit Part No.	Piston size (mm)	Over size (mm)	Ring Set Part No.
8047DA	76,92	Std.	RSC7700	8099DA	81,92	Std.	RSC8200	8036DA	86,42	Std.	RSC8650
8047D050	77,42	+0,50	RSC7750	8099D050	82,42	+0,50	RSC8250	8036D050	86,92	+0,50	RSC8700
8047D100	77,92	+1,00	RSC7800	8099D100	82,92	+1,00	RSC8300	8036D100	87,42	+1,00	RSC8750
8047D150	78,42	+1,50	RSC7850	8099D150	83,42	+1,50	RSC8350				
8047D200	78,92	+2,00	RSC7900	8099D200	83,92	+2,00	RSC8400				

	set includes		
Clip Part No.	CA18	CA18	CW18
Pin Part No.	WP039	WP039	WP042
Rings	included	included	included
Price-Code	6	6	6/1
Stroke	83	83	83
Comp. Height (mm)	41.70	41.70	41.70

	extra parts		
Top End Gasket Kit	D2061-EST	-	D2062-EST
Wössner Connecting rods	-	-	-
Needle bearing	-	-	-
Main bearing	-	-	-

## Rotax® - 2 stroke



<b>Model</b>	SWM175 <b>New!</b>	SWM250 <b>New!</b>
<b>Years</b>	-	-
<b>Displ. (cc)</b>	175	247,3

Piston Kit Part No.	Piston size (mm)	Over size (mm)	Ring Set Part No.	Piston Kit Part No.	Piston size (mm)	Over size (mm)	Ring Set Part No.
8289DA	61,94	Std.	RDB6200	8290DA	73,93	Std.	RDB7400
8289D050	62,44	+0,50	RDB6250	8290D050	74,43	+0,50	RDB7450
8289D100	62,94	+1,00	RDB6300	8290D100	74,93	+1,00	RDC7500
8289D150	63,44	+1,50	RDB6350				
8289D200	63,94	+2,00	RDB6400				

set includes		
<b>Clip Part No.</b>	CW18	CW18
<b>Pin Part No.</b>	WP040	WP033
<b>Rings</b>	included	included
<b>Price-Code</b>	3	3
<b>Stroke</b>	57.5	57.5
<b>Wössner/ OEM Comp. ratio</b>	-	-
<b>Comp. Height (mm)</b>	30	34

extra parts		
<b>Top End Gasket Kit</b>	-	-
<b>Wössner Connecting rods</b>	-	-
<b>Needle bearing</b>	-	-
<b>Main bearing</b>	-	-

## Sherco® - 2 stroke

<b>Model</b>	250SE / 250SE-R <b>New!</b>	300SE / 300SE-R <b>New!</b>
<b>Years</b>	13-14	13-14
<b>Displ. (cc)</b>	249	300

Piston Kit Part No.	Piston size (mm)	Over size (mm)	Ring Set Part No.	Piston Kit Part No.	Piston size (mm)	Over size (mm)	Ring Set Part No.
8169DA	66,34	Std.	RDB6640	8294DA	71,93	Std.	RSB7200
8169DB	66,35	+0,01	RDB6640	8294DB	71,94	+0,01	RSB7200
8169DC	66,36	+0,02	RDB6640	8294DC	71,95	+0,02	RSB7200

set includes		
<b>Clip Part No.</b>	CW18	CW18
<b>Pin Part No.</b>	WP033	WP033
<b>Rings</b>	included	included
<b>Price-Code</b>	3/1	6/1
<b>Stroke</b>	72	72
<b>Comp. Height (mm)</b>	38	38

extra parts		
<b>Top End Gasket Kit</b>	-	-
<b>Wössner Connecting rods</b>	-	-
<b>Needle bearing</b>	-	-
<b>Main bearing</b>	-	-

## Sherco® - 4 stroke

<b>Model</b>	SE2,5I-F <b>New!</b>	SE3, 0I-F <b>New!</b>
<b>Years</b>	08-12	-
<b>Displ. (cc)</b>	250	247,3

Piston Kit Part No.	Piston size (mm)	Over size (mm)	Ring Set Part No.	Piston Kit Part No.	Piston size (mm)	Over size (mm)	Ring Set Part No.
8905DA	77,94	Std.	780XAS-2	8906DA		Std.	
8905DB	77,95	+0,50	780XAS-2	8906DB		+0,50	
8905DC	77,96	+1,00	780XAS-2	8906DC		+1,00	

set includes	
<b>Clip Part No.</b>	CW16
<b>Pin Part No.</b>	WP070
<b>Rings</b>	included
<b>Price-Code</b>	5/1
<b>Stroke</b>	52.2
<b>Wössner/ OEM Comp. ratio</b>	13.2:1 13.2:1
<b>Dome Volume (CC)</b>	+3.6 cm <sup>3</sup>
<b>Comp. Height (mm)</b>	18.40

extra parts	
<b>Top End Gasket Kit</b>	-
<b>Wössner Connecting rods</b>	-
<b>Needle bearing</b>	-
<b>Main bearing</b>	-



## Suzuki® - 2 stroke



Model	RM65	RM80 / DS80	RM80
Years	00-12	77-81 / thru `00	86-87
Displ. (cc)	65	80	80

Piston Kit Part No.	Piston size (mm)	Over size (mm)	Ring Set Part No.	Piston Kit Part No.	Piston size (mm)	Over size (mm)	Ring Set Part No.	Piston Kit Part No.	Piston size (mm)	Over size (mm)	Ring Set Part No.
8196DA	44,45	Std.	RSB4500	8226DA	48,95	Std.	RSB4900	8227DA	47,45	Std.	RSB4750
8196DB	44,46	+0,01	RSB4500	8226D050	49,45	+0,50	RSB4950	8227D050	47,95	+0,50	RSB4800
8196DC	44,47	+0,02	RSB4500	8226D100	49,95	+1,00	RSB5000	8227D100	48,45	+1,00	RSB4850
8196DD	44,48	+0,03	RSB4500	8226D150	50,45	+1,50	RSB5050	8227D150	48,95	+1,50	RSB4900
				8226D200	50,95	+2,00	RSB5100	8227D200	49,45	+2,00	RSB4950

	set includes		
Clip Part No.	CW12	CW12	CW14
Pin Part No.	WP091	WP091	WP058
Rings	included	included	included
Price-Code	1	1/1	1/1
Stroke	41.6	42	46.8
Comp. Height (mm)	23.60	27.5	27

	extra parts		
Top End Gasket Kit	D2011-EST	-	-
Wössner Connecting rods	P2001 `03-05	-	P2059
Needle bearing	N1036	N1036	N1036
Main bearing	-	-	-

## Suzuki® - 2 stroke



Model	RM80	RM80 International Bore	RM80 US Bore
Years	89-90	91-01	91-01
Displ. (cc)	82	82	82

Piston Kit Part No.	Piston size (mm)	Over size (mm)	Ring Set Part No.	Piston Kit Part No.	Piston size (mm)	Over size (mm)	Ring Set Part No.	Piston Kit Part No.	Piston size (mm)	Over size (mm)	Ring Set Part No.
8191DA	47,45	Std.	RSB4750	8231DA	46,45	Std.	RSB4650	8270DA	47,45	Std.	RSB4750
8191D050	47,95	+0,50	RSB4800	8231DB	46,46	+0,01	RSB4650	8270D050	47,95	+0,50	RSB4800
8191D100	48,45	+1,00	RSB4850					8270D100	48,45	+1,00	RSB4850
8191D150	48,95	+1,50	RSB4900					8270D150	48,95	+1,50	RSB4900
8191D200	49,45	+2,00	RSB4950					8270D200	49,45	+2,00	RSB4950

	set includes		
Clip Part No.	CW14	CW14	CW14
Pin Part No.	WP058	WP058	WP058
Rings	included	included	included
Price-Code	1/1	1/1	1/1
Stroke	46.8	46.8	46.8
Comp. Height (mm)	27	27	27

	extra parts		
Top End Gasket Kit	-	-	-
Wössner Connecting rods	P2059 '86-89	-	-
Needle bearing	N1036	N1036	N1036
Main bearing	1 x MB6204C3 Left 1 MB6304C3 Right	2 x MB6304C3	2 x MB6304C3

## Suzuki® - 2 stroke



Model	RM85	RM100	RM125
Years	02-14	03	77-80
Displ. (cc)	84	99	123

Piston Kit Part No.	Piston size (mm)	Over size (mm)	Ring Set Part No.	Piston Kit Part No.	Piston size (mm)	Over size (mm)	Ring Set Part No.	Piston Kit Part No.	Piston size (mm)	Over size (mm)	Ring Set Part No.
8103DA	47,95	Std.	RSB4800	8254DA	52,45	Std.	RSB5250	8192DA	53,94	Std.	RDB5400
8103DB	47,96	+0,01	RSB4800	8254D050	52,95	+0,50	RSB5300	8192D050	54,44	+0,50	RDB5450
8103DC	47,97	+0,02	RSB4800	8254D100	53,45	+1,00	RSB5350	8192D100	54,94	+1,00	RDB5500
8103D050	48,45	+0,50	RSB4850	8254D150	53,95	+1,50	RSB5400	8192D150	55,44	+1,50	RDB5550
8103D100	48,95	+1,00	RSB4900	8254D200	54,45	+2,00	RSB5450	8192D200	55,94	+2,00	RDB5600
8103D200	49,95	+2,00	RSB5000								
8103D400	51,95	+4,00	RSB5200								
8103D500	52,95	+5,00	RSB5300								

	set includes		
Clip Part No.	CW14	CW14	CW14
Pin Part No.	WP058	WP025	WP025
Rings	included	included	included
Price-Code	1	1	2/1
Stroke	46.8	45.8	54
Comp. Height (mm)	27	26	30.50

	extra parts		
Top End Gasket Kit	D2026-EST	D2080-EST	-
Wössner Connecting rods	P2007 `02-14	P2005	-
Needle bearing	N1006	N1007	N1008
Main bearing	2 x MB6304C3	2 x MB6304C3	-

## Suzuki® - 2 stroke



Model	RM125	RM125	RM125
Years	81-84	85-86	87
Displ. (cc)	123	123	123

Piston Kit Part No.	Piston size (mm)	Over size (mm)	Ring Set Part No.	Piston Kit Part No.	Piston size (mm)	Over size (mm)	Ring Set Part No.	Piston Kit Part No.	Piston size (mm)	Over size (mm)	Ring Set Part No.
8124DA	53,94	Std.	RDB5400	8123DA	53,94	Std.	RDB5400	8122DA	53,94	Std.	RSB5400
8124D050	54,44	+0,50	RDB5450	8123D050	54,44	+0,50	RDB5450	8122D050	54,44	+0,50	RSB5450
8124D075	54,69	+0,75	RDB5475	8123D075	54,69	+0,75	RDB5475	8122D100	54,94	+1,00	RSB5500
8124D100	54,94	+1,00	RDB5500	8123D100	54,94	+1,00	RDB5500	8122D150	55,44	+1,50	RSB5550
8124D150	55,44	+1,50	RDB5550	8123D150	55,44	+1,50	RDB5550	8122D200	55,94	+2,00	RSB5600
8124D200	55,94	+2,00	RDB5600	8123D200	55,94	+2,00	RDB5600				

set includes			
Clip Part No.	CW14	CW14	CW14
Pin Part No.	WP025	WP025	WP025
Rings	included	included	included
Price-Code	2/1	2/1	2/1
Stroke	54	54	54
Comp. Height (mm)	29.50	29.50	29.50

extra parts			
Top End Gasket Kit	-	-	-
Wössner Connecting rods	P2040 `84-86	P2040 `84-86	P2015
Needle bearing	N1008	N1008	N1008
Main bearing	1 x MB6205C3 Left 1 x MB6322C3 Right	1 x MB6205C3 Left 1 x MB6322C3 Right	1 x MB6205C3 Left 1 x MB6322C3 Right

## Suzuki® - 2 stroke



Model	RM125	RM125	RM125
Years	88	89-99	00-03
Displ. (cc)	123	123	125

Piston Kit Part No.	Piston size (mm)	Over size (mm)	Ring Set Part No.	Piston Kit Part No.	Piston size (mm)	Over size (mm)	Ring Set Part No.	Piston Kit Part No.	Piston size (mm)	Over size (mm)	Ring Set Part No.
8138DA	53,94	Std.	RSB5400	8055DA	53,95	Std.	RSB5400	8061DA	53,95	Std.	RSB5400
8138D050	54,44	+0,50	RSB5450	8055DB	53,96	+0,01	RSB5400	8061DB	53,96	+0,01	RSB5400
8138D150	55,44	+1,50	RSB5550	8055DC	53,97	+0,02	RSB5400	8061DC	53,97	+0,02	RSB5400
8138D200	55,94	+2,00	RSB5600	8055D050	54,45	+0,50	RSB5450	8061D050	54,45	+0,50	RSB5450
				8055D100	54,95	+1,00	RSB5500	8061D100	54,95	+1,00	RSB5500
				8055D150	55,45	+1,50	RSB5550	8061D150	55,45	+1,50	RSB5550
				8055D200	55,95	+2,00	RSB5600	8061D200	55,95	+2,00	RSB5600

	set includes		
Clip Part No.	CW15	CW15	CW15
Pin Part No.	WP032	WP032	WP032
Rings	included	included	included
Price-Code	2/1	2	2
Stroke	54	54	54.5
Comp. Height (mm)	29.50	29.50	29.50

	extra parts		
Top End Gasket Kit	-	D2027-EST	D2027-EST
Wössner Connecting rods	P2015	P2015 `88-96 P2014 `97-98 P2013 `99-03	P2013
Needle bearing	N1010	N1010	N1010
Main bearing	1 x MB6205C3 Left 1 x MB6322C3 Right	2 x MB6322C4	2 x MB6322C4

## Suzuki® - 2 stroke



Model	RM125	TS125 / RV125 / TS125ER / TS125X	RG125
Years	04-12	71-81 / 74-78 / 79-81 / 84-89	85-91
Displ. (cc)	125	125	125

Piston Kit Part No.	Piston size (mm)	Over size (mm)	Ring Set Part No.	Piston Kit Part No.	Piston size (mm)	Over size (mm)	Ring Set Part No.	Piston Kit Part No.	Piston size (mm)	Over size (mm)	Ring Set Part No.
8098DA	53,95	Std.	RSB5400	8146DA	55,94	Std.	RDB5600	8028DA	53,94	Std.	RDB5400
8098DB	53,96	+0,01	RSB5400	8146D050	56,44	+0,50	RDB5650	8028D050	54,44	+0,50	RDB5450
8098DC	53,97	+0,02	RSB5400	8146D100	56,94	+1,00	RDB5700	8028D100	54,94	+1,00	RDB5500
8098D200	55,95	+2,00	RSB5600	8146D150	57,44	+1,50	RDB5750	8028D150	55,44	+1,50	RDB5550
8098D400	57,95	+4,00	RSB5800	8146D200	57,94	+2,00	RDB5800	8028D200	55,94	+2,00	RDB5600

	set includes		
Clip Part No.	CW15	CW14	CW14
Pin Part No.	WP032	WP025	WP025
Rings	included	included	included
Price-Code	2	2/1	2/1
Stroke	54.5	50	54
Comp. Height (mm)	29.50	29	28

	extra parts		
Top End Gasket Kit	D2027-EST	D2050-EST	-
Wössner Connecting rods	P2016 `04-07	-	-
Needle bearing	N1010	-	-
Main bearing	2 x MB6322C4	-	-

## Suzuki® - 2 stroke



Model	TSR125	PE175	TS185 / TC185 / DS185
Years	89-95	80-84	74-77 / 71-81 / 78-80
Displ. (cc)	125	172	185

Piston Kit Part No.	Piston size (mm)	Over size (mm)	Ring Set Part No.	Piston Kit Part No.	Piston size (mm)	Over size (mm)	Ring Set Part No.	Piston Kit Part No.	Piston size (mm)	Over size (mm)	Ring Set Part No.
8009DA	55,94	Std.	RDB5600	8193DA	61,94	Std.	RDB6200	8281DA	63,93	Std.	RDB6400
8009D050	56,44	+0,50	RDB5650	8193D050	62,44	+0,50	RDB6250	8281D050	64,43	+0,50	RDB6450
8009D100	56,94	+1,00	RDB5700	8193D100	62,94	+1,00	RDB6300	8281D100	64,93	+1,00	RDB6500
8009D150	57,44	+1,50	RDB5750	8193D150	63,44	+1,50	RDB6350	8281D150	65,43	+1,50	RDB6550
8009D200	57,94	+2,00	RDB5800	8193D200	63,94	+2,00	RDB6400	8281D200	65,93	+2,00	RDB6600

	set includes		
Clip Part No.	CW16	CW16	CW16
Pin Part No.	WP036	WP041	WP027
Rings	included	included	included
Price-Code	2	3/1	3
Stroke	50	57	57
Comp. Height (mm)	28.50	31.8	32

	extra parts		
Top End Gasket Kit	D2051-EST	-	-
Wössner Connecting rods	-	-	-
Needle bearing	N1020	N1016	N1016
Main bearing	-	-	-

## Suzuki® - 2 stroke



Model	TS200R	TS250	RM250 / PE250
Years	all	73-81	77-81
Displ. (cc)	200	249	246

Piston Kit Part No.	Piston size (mm)	Over size (mm)	Ring Set Part No.	Piston Kit Part No.	Piston size (mm)	Over size (mm)	Ring Set Part No.	Piston Kit Part No.	Piston size (mm)	Over size (mm)	Ring Set Part No.
8046D100	66,93	+1,00	RDB6700	8204D100	70,94	+1,00	RDB7100	8194DA	66,94	Std.	RDB6700
				8204D150	71,44	+1,50	RDB7150	8194D050	67,44	+0,50	RDB6750
				8204D200	71,94	+2,00	RDB7200	8194D100	67,94	+1,00	RDB6800
								8194D150	68,44	+1,50	RDB6850
								8194D200	68,94	+2,00	RDB6900

	set includes		
Clip Part No.	CW18	CW18	CW18
Pin Part No.	WP033	WP033	WP033
Rings	included	included	included
Price-Code	3	3/1	3/1
Stroke	56.8	64	70
Comp. Height (mm)	28.5	33	37

	extra parts		
Top End Gasket Kit	-	-	-
Wössner Connecting rods	-	-	-
Needle bearing	-	N1024	N1022
Main bearing	-	-	-



## Suzuki® - 2 stroke



<b>Model</b>	RM250	RM250	RM250
<b>Years</b>	82-85	86	87-88
<b>Displ. (cc)</b>	246	246	246

Piston Kit Part No.	Piston size (mm)	Over size (mm)	Ring Set Part No.	Piston Kit Part No.	Piston size (mm)	Over size (mm)	Ring Set Part No.	Piston Kit Part No.	Piston size (mm)	Over size (mm)	Ring Set Part No.
8159DA	69,94	Std.	RSB7000	8158DA	66,94	Std.	RSB6700	8157DA	66,94	Std.	RSB6700
8159D050	70,44	+0,50	RSB7050	8158D050	67,44	+0,50	RSB6750	8157D050	67,44	+0,50	RSB6750
8159D075	70,69	+0,75	RSB7075	8158D100	67,94	+1,00	RSB6800	8157D100	67,94	+1,00	RSB6800
8159D100	70,94	+1,00	RSB7100	8158D150	68,44	+1,50	RSB6850	8157D150	68,44	+1,50	RSB6850
8159D150	71,44	+1,50	RSB7150					8157D200	68,94	+2,00	RSB6900
8159D200	71,94	+2,00	RSB7200								

set includes			
<b>Clip Part No.</b>	CW18	CW18	CW18
<b>Pin Part No.</b>	WP033	WP033	WP033
<b>Rings</b>	included	included	included
<b>Price-Code</b>	3/1	3/1	3/1
<b>Stroke</b>	64	70	70
<b>Comp. Height (mm)</b>	32.8	37	37

extra parts			
<b>Top End Gasket Kit</b>	-	-	-
<b>Wössner Connecting rods</b>	-	-	-
<b>Needle bearing</b>	N1022	N1022	N1022
<b>Main bearing</b>	1 x MB6206C3 Left 1 x MB6305C3 Right	1 x MB6206C3 Left 1 x MB6305C3 Right	1 x MB6206C3 Left 1 x MB6305C3 Right

## Suzuki® - 2 stroke



Model	RM250 / RMX250	RM250	RM250
Years	89-95 / 89-99	96-97	98
Displ. (cc)	246	249	249

Piston Kit Part No.	Piston size (mm)	Over size (mm)	Ring Set Part No.	Piston Kit Part No.	Piston size (mm)	Over size (mm)	Ring Set Part No.	Piston Kit Part No.	Piston size (mm)	Over size (mm)	Ring Set Part No.
8022DA	66,94	Std.	RDB6700	8058DA	66,34	Std.	RDB6640	8140DA	66,34	Std.	RDB6640
8022DB	66,95	+0,01	RDB6700	8058DB	66,35	+0,01	RDB6640	8140DB	66,35	+0,01	RDB6640
8022DC	66,96	+0,02	RDB6700	8058DC	66,36	+0,02	RDB6640	8140DC	66,36	+0,02	RDB6640
8022D050	67,44	+0,50	RDB6750					8140D210	68,44	+2,10	RDB6850
8022D100	67,94	+1,00	RDB6800								
8022D200	68,94	+2,00	RDB6900								

set includes			
Clip Part No.	CW18	CW18	CW18
Pin Part No.	WP033	WP033	WP033
Rings	included	included	included
Price-Code	3	3/1	3/1
Stroke	70.8	72	72
Comp. Height (mm)	37	38	38

extra parts			
Top End Gasket Kit	D2028-EST / D2029-EST	D2030-EST	D2030-EST
Wössner Connecting rods	P2027	P2026	P2026
Needle bearing	N1022	N1022	N1022
Main bearing	2 x MB6305C3 '89-93 2 x MB6328C3 '94-04	2 x MB6328C3	2 x MB6328C3

## Suzuki® - 2 stroke



Model	RM250	RM250	RM250
Years	99	00-02	03-12
Displ. (cc)	249	249	249

Piston Kit Part No.	Piston size (mm)	Over size (mm)	Ring Set Part No.	Piston Kit Part No.	Piston size (mm)	Over size (mm)	Ring Set Part No.	Piston Kit Part No.	Piston size (mm)	Over size (mm)	Ring Set Part No.
8058DA	66,34	Std.	RDB6640	8059DA	66,34	Std.	RDB6640	8086DA	66,34	Std.	RDB6640
8058DB	66,35	+0,01	RDB6640	8059DB	66,35	+0,01	RDB6640	8086DB	66,35	+0,01	RDB6640
8058DC	66,36	+0,02	RDB6640	8059DC	66,36	+0,02	RDB6640	8086DC	66,36	+0,02	RDB6640
				8059D210	68,44	+2,10	RDB6850	8086D060	66,94	+0,60	RDB6700
								8086D110	67,44	+1,10	RDB6750

set includes			
Clip Part No.	CW18	CW18	CW18
Pin Part No.	WP033	WP033	WP033
Rings	included	included	included
Price-Code	3/1	3/1	3
Stroke	72	72	72
Comp. Height (mm)	38	38	38

extra parts			
Top End Gasket Kit	D2031-EST `99-00	D2031-EST `99-00 D2032-EST `01-02	D2033-EST
Wössner Connecting rods	P2026	P2026	P2025 `03-08
Needle bearing	N1022	N1022	N1022
Main bearing	2 x MB6328C3	2 x MB6328C3	2 x MB6328C3 `94-04

## Suzuki® - 2 stroke



Model	RM250 Single Ring	RGV250 / RGV250 Single Ring	TSX250 / RH240 / TSX240
Years	03-12	92-98	86-87
Displ. (cc)	249	249	250

Piston Kit Part No.	Piston size (mm)	Over size (mm)	Ring Set Part No.	Piston Kit Part No.	Piston size (mm)	Over size (mm)	Ring Set Part No.	Piston Kit Part No.	Piston size (mm)	Over size (mm)	Ring Set Part No.
8087DA	66,34	Std.	RSB6640	8039DA	55,95	Std.	RSB5600	8013DA	69,93	Std.	RDB7000
8087DB	66,35	+0,01	RSB6640	8039DB	55,96	+0,01	RSB5600	8013D050	70,43	+0,50	RDB7050
8087DC	66,36	+0,02	RSB6640	8039DC	55,97	+0,02	RSB5600	8013D100	70,93	+1,00	RDB7100
				8039D050	56,45	+0,50	RSB5650	8013D150	71,43	+1,50	RDB7150
				8039D100	56,94	+1,00	RSB5700	8013D200	71,93	+2,00	RDB7200

	set includes		
Clip Part No.	CW18	CW16	CW18
Pin Part No.	WP033	WP036	WP033
Rings	included	included	included
Price-Code	3/1	2	3/1
Stroke	72	50.6	64
Comp. Height (mm)	38	22.20	31

	extra parts		
Top End Gasket Kit	D2033-EST	-	-
Wössner Connecting rods	P2025	-	-
Needle bearing	N1022	-	-
Main bearing	2 x MB6328C3 `94-04	-	-

## Suzuki® - 2 stroke



Model	RM500
Years	-
Displ. (cc)	500

Piston Kit Part No.	Piston size (mm)	Over size (mm)	Ring Set Part No.
8271DA	88,40	Std.	RSC8850
8271D050	88,90	+0,50	RSC8900
8271D100	89,40	+1,00	RSC8950

set includes	
Clip Part No.	CW18
Pin Part No.	WP042
Rings	included
Price-Code	6/1
Stroke	80
Comp. Height (mm)	41.5

extra parts	
Top End Gasket Kit	-
Wössner Connecting rods	-
Needle bearing	-
Main bearing	-

Sven Breugelsman  
JM Racing KTM  
World Champion MX3 2008



## Suzuki® - 4 stroke



Verdichtungen beziehen sich auf Standardmaße „-DA“

Compression ratio refer to standard sizes “-DA”

Model	DRZ250 Pro Series	RM-Z250	RM-Z250 Pro-Series
Years	01-07	04-06	04-06
Displ. (cc)	249	249	249

Piston Kit Part No.	Piston size (mm)	Over size (mm)	Ring Set Part No.	Piston Kit Part No.	Piston size (mm)	Over size (mm)	Ring Set Part No.	Piston Kit Part No.	Piston size (mm)	Over size (mm)	Ring Set Part No.
8678DA	72,95	Std.	730XDS	8582DA	76,96	Std.	770XAS-2	8661DA	76,96	Std.	770XAS-2
				8582DB	76,97	+0,01	770XAS-2	8661DB	76,97	+0,01	770XAS-2
				8582DC	76,98	+0,02	770XAS-2	8661DC	76,98	+0,02	770XAS-2
				8582D600	82,96	+6,00	830XSY				

	set includes		
Clip Part No.	CW19	CW16	CW16
Pin Part No.	WP028	WP059	WP059
Rings	included	included	included
Price-Code	4/1	DA - DC = 5 D600 = 7	5/1
Stroke	59.6	53.6	53.6
Wössner/ OEM Comp. ratio	11.5:1 10.4:1	- 12.6:1	13.2:1 12.6:1
Dome Volume (CC)	-1.4 cm <sup>3</sup>	-5.85 cm <sup>3</sup>	-4 cm <sup>3</sup>
Comp. Height (mm)	24	19.60	19.60

	extra parts		
Top End Gasket Kit	-	D4013-EST	D4013-EST
Wössner Connecting rods	-	P4002	P4002
Needle bearing	-	-	-
Main bearing	-	2 x MB6206RSI	2 x MB6206RSI

## Suzuki® - 4 stroke

Verdichtungen beziehen sich auf Standardmaße „-DA“  
 Compression ratio refer to standard sizes “-DA”



Model	RM-Z250	RM-Z250 Pro Series	RM-Z250
Years	07-09	07-09	10-14
Displ. (cc)	249	249	249

Piston Kit Part No.	Piston size (mm)	Over size (mm)	Ring Set Part No.	Piston Kit Part No.	Piston size (mm)	Over size (mm)	Ring Set Part No.	Piston Kit Part No.	Piston size (mm)	Over size (mm)	Ring Set Part No.
8666DA	76,96	Std.	770XAS-2	8672DA	76,96	Std.	770XAS-2	8781DA	76,96	Std.	770XAS-2
8666DB	76,97	+0,01	770XAS-2	8672DB	76,97	+0,01	770XAS-2	8781DB	76,97	+0,01	770XAS-2
8666DC	76,98	+0,02	770XAS-2	8672DC	76,98	+0,02	770XAS-2	8781DC	76,98	+0,02	770XAS-2

set includes			
Clip Part No.	CW16	CW16	CW16
Pin Part No.	WP059	WP070	WP070
Rings	included	included	included
Price-Code	5/1	5/1	5/1
Stroke	53.6	53.6	53.6
Wössner/ OEM Comp. ratio	- 13.4:1	13.9:1 13.4:1	13.6:1 13.5:1
Dome Volume (CC)	-3.27 cm <sup>3</sup>	-2.5 cm <sup>3</sup>	-2.6 cm <sup>3</sup>
Comp. Height (mm)	19.60	19.60	19.60

extra parts			
Top End Gasket Kit	D4022-EST	D4022-EST	D4044-EST
Wössner Connecting rods	P4004 `07-14	P4004 `07-14	P4004 `07-14
Needle bearing	-	-	-
Main bearing	2 x MB830046-14	2 x MB830046-14	2 x MB830046-20

## Suzuki® - 4 stroke



Verdichtungen beziehen sich auf Standardmaße „-DA“

Compression ratio refer to standard sizes “-DA”

Model	RM-Z250 Pro Series	DR350R / DR350S / DR350SE	DR-Z400E / DR-Z400S
Years	10-14	90-99	00-14
Displ. (cc)	249	349	398 / 439 / 450

Piston Kit Part No.	Piston size (mm)	Over size (mm)	Ring Set Part No.	Piston Kit Part No.	Piston size (mm)	Over size (mm)	Ring Set Part No.	Piston Kit Part No.	Piston size (mm)	Over size (mm)	Ring Set Part No.
8795DA	76,96	Std.	770XAS-2	8600DA	78,94	Std.	790XDS	8563DA	89,94	Std.	900XSY
8795DB	76,97	+0,01	770XAS-2	8600D100	79,94	+1,00	800XDS	8563DB	89,95	+0,01	900XSY
8795DC	76,98	+0,02	770XAS-2	8600D200	80,94	+2,00	810XSY	8563DC	89,96	+0,02	900XSY
				8600D300	81,94	+3,00	820XSY	8563D400	93,94	+4,00	940XSY
				8600D400	82,94	+4,00	830XSY	8563D550	95,44	+5,50	955XSY

	set includes		
Clip Part No.	CW16	CW20	CW20
Pin Part No.	WP070	WP029	WP038
Rings	included	included	included
Price-Code	5	5	7
Stroke	53.6	71.2	62.6
Wössner/ OEM Comp. ratio	14:1 13.5:1	- 9.5:1	- 12.2:1
Dome Volume (CC)	-2.1 cm <sup>3</sup>	+3.5 cm <sup>3</sup>	-2 cm <sup>3</sup> / -5.25 cm <sup>3</sup>
Comp. Height (mm)	19.60	25	25.3

	extra parts		
Top End Gasket Kit	D4044-EST	-	D4023-EST
Wössner Connecting rods	P4004	-	P4009 `00-13
Needle bearing	-	-	-
Main bearing	2 x MB830046-20	-	2 x MB6306R/3



## Suzuki® - 4 stroke



Verdichtungen beziehen sich auf Standardmaße „-DA“

Compression ratio refer to standard sizes “-DA”

Model	DR-Z400E / DR-Z400S ProSeries	RM-Z450	RM-Z450 Pro Series - 2. Ring
Years	00-14	05-07	05-07
Displ. (cc)	398	449	449

Piston Kit Part No.	Piston size (mm)	Over size (mm)	Ring Set Part No.	Piston Kit Part No.	Piston size (mm)	Over size (mm)	Ring Set Part No.	Piston Kit Part No.	Piston size (mm)	Over size (mm)	Ring Set Part No.
8567DA	89,94	Std.	900XSY	8606DA	95,46	Std.	955XSY	8616DA	95,46	Std.	955XSY
8567DB	89,95	+0,01	900XSY	8606DB	95,47	+0,01	955XSY	8616DB	95,47	+0,01	955XSY
8567DC	89,96	+0,02	900XSY	8606DC	95,48	+0,02	955XSY	8616DC	95,48	+0,02	955XSY
8567D550	95,44	+5,50	955XSY	8606D200	97,46	+2,00	975XSY				
				8606D450	99,96	+4,50	1000XSY				

	set includes		
Clip Part No.	CW20	CW19	CW19
Pin Part No.	WP029	WP037	WP071
Rings	included	included	included
Price-Code	7	7	7
Stroke	62.6	62.6	62.8
Wössner/ OEM Comp. ratio	13.5:1 12.2:1	- 12.0:1	13.5:1 12.0:1
Dome Volume (CC)	+0.5 cm <sup>3</sup>	-3.14 cm <sup>3</sup>	+1.4 cm <sup>3</sup>
Comp. Height (mm)	25.3	22.3	22.3

	extra parts		
Top End Gasket Kit	D4023-EST	D4024-EST '05-06 D4025-EST '07	D4024-EST '05-06 D4025-EST '07
Wössner Connecting rods	P4009	P4012	P4012
Needle bearing	-	-	-
Main bearing	2 x MB6306R/3	2 x MB85C072C	2 x MB85C072C

## Suzuki® - 4 stroke



Verdichtungen beziehen sich auf Standardmaße „-DA“

Compression ratio refer to standard sizes “-DA”

**New!**

Model	RM-Z450	RM-Z450 Pro Series - 2. Ring	RM-Z450
Years	08-12	08-12	13-14
Displ. (cc)	449	449	449

Piston Kit Part No.	Piston size (mm)	Over size (mm)	Ring Set Part No.	Piston Kit Part No.	Piston size (mm)	Over size (mm)	Ring Set Part No.	Piston Kit Part No.	Piston size (mm)	Over size (mm)	Ring Set Part No.
8716DA	95,96	Std.	960ADS-2	8717DA	95,96	Std.	960ADS-2	8886DA	95,96	Std.	960ADS-2
8716DB	95,97	+0,01	960ADS-2	8717DB	95,97	+0,01	960ADS-2	8886DB	95,97	+0,01	960ADS-2
8716DC	95,98	+0,02	960ADS-2	8717DC	95,98	+0,02	960ADS-2	8886DC	95,98	+0,02	960ADS-2

	set includes		
Clip Part No.	CW19	CW19	CW19
Pin Part No.	WP037	WP071	WP071
Rings	included	included	included
Price-Code	7	7	7
Stroke	62.1	62.1	62.1
Wössner/ OEM Comp. ratio	- 12.2:1	13.5:1 12.2:1	12.5:1 12.5:1
Dome Volume (CC)	-0.8 cm <sup>3</sup>	+3.4 cm <sup>3</sup>	-1 cm <sup>3</sup>
Comp. Height (mm)	23.10	23.10	22.90

	extra parts		
Top End Gasket Kit	D4026-EST	D4026-EST	D4026-EST
Wössner Connecting rods	P4013 `08-14	P4013 `08-14	P4062 `13
Needle bearing	-	-	-
Main bearing	1 x MB83C072C Right 1 x MB830053-4 Left	1 x MB83C072C Right 1 x MB830053-4 Left	1 x MB83C072C Right 1 x MB830053-4 Left

## Suzuki® - 4 stroke



Verdichtungen beziehen sich auf Standardmaße „-DA“

Compression ratio refer to standard sizes “-DA”

**New!**

Model	RM-Z450	DR600 / SP600 Djebel + 1.00 Overbore	DR650R / DR650S / DR650SE
Years	13-14	85-89 / 85-89	90-95
Displ. (cc)	449	589	641

Piston Kit Part No.	Piston size (mm)	Over size (mm)	Ring Set Part No.	Piston Kit Part No.	Piston size (mm)	Over size (mm)	Ring Set Part No.	Piston Kit Part No.	Piston size (mm)	Over size (mm)	Ring Set Part No.
8887DA	95,96	Std.	960DS-2	8503DA	94,94	+1,00	950XSY	8503DA	94,94	Std.	950XSY
8887DB	95,97	+0,01	960DS-2	8503D100	95,94	+2,00	960XSY	8503D100	95,94	+1,00	960XSY
8887DC	95,98	+0,02	960DS-2	8503D150	96,44	+2,50	965XSY	8503D150	96,44	+1,50	965XSY
				8503D200	96,94	+3,00	970XSY	8503D200	96,94	+2,00	970XSY

	set includes		
Clip Part No.	CW19	CW23	CW23
Pin Part No.	WP071	WP024	WP024
Rings	included	included	included
Price-Code	7	7	7
Stroke	62.1	85	90.4
Wössner/ OEM Comp. ratio	13.5:1 12.5:1	10:1 8.5:1	10:1 9.7:1
Dome Volume (CC)	-0.4 cm <sup>3</sup>	+6.1 cm <sup>3</sup>	+6.1 cm <sup>3</sup>
Comp. Height (mm)	22.9	28.9	28.9

	extra parts		
Top End Gasket Kit	D4026-EST	-	-
Wössner Connecting rods	P4013 `08-14	-	-
Needle bearing	-	-	-
Main bearing	1 x MB83C072C Right 1 x MB830053-4 Left	-	-

## Suzuki® - 4 stroke



Verdichtungen beziehen sich auf Standardmaße „-DA“

Compression ratio refer to standard sizes “-DA”

Model	DR650SE Pro Series
Years	96-09
Displ. (cc)	644

Piston Kit Part No.	Piston size (mm)	Over size (mm)	Ring Set Part No.
8591DA	99,94	Std.	1000XSY
8591DB	99,95	+0,01	1000XSY
8591DC	99,96	+0,02	1000XSY
8591D100	100,94	+1,00	1010XSY

	set includes
Clip Part No.	CW23
Pin Part No.	WP024
Rings	included
Price-Code	7
Stroke	82
Wössner/ OEM Comp. ratio	- 9.5:1
Dome Volume (CC)	-6.7 cm <sup>3</sup>
Comp. Height (mm)	28.70

	extra parts
Top End Gasket Kit	-
Wössner Connecting rods	-
Needle bearing	-
Main bearing	-

## TM® - 2 stroke



**New!**

Model	85 Cross	125 Cross & Enduro	250 Cross & Enduro Domed 2. Ring
Years	08-14	92-14	99-14
Displ. (cc)	85	123,5	249

Piston Kit Part No.	Piston size (mm)	Over size (mm)	Ring Set Part No.	Piston Kit Part No.	Piston size (mm)	Over size (mm)	Ring Set Part No.	Piston Kit Part No.	Piston size (mm)	Over size (mm)	Ring Set Part No.
8285DA	47,85	Std.	RSB4800	8135DA	53,94	Std.	RSB5400	8136DA	66,33	Std.	RDB6640
8285DB	47,86	+0,01	RSB4800	8135DB	53,95	+0,01	RSB5400	8136DB	66,34	+0,01	RDB6640
8285DC	47,87	+0,02	RSB4800	8135DC	53,96	+0,02	RSB5400	8136DC	66,35	+0,02	RDB6640
				8135DD	53,97	+0,03	RSB5400	8136DD	66,36	+0,03	RDB6640
				8135DE	53,98	+0,04	RSB5400				

	set includes		
Clip Part No.	CW13	CW15	CW18
Pin Part No.	WP088	WP032	WP033
Rings	included	included	included
Price-Code	1	2	3/1
Stroke	47	54.5	72
Comp. Height (mm)	24	29	38

	extra parts		
Top End Gasket Kit	-	-	-
Wössner Connecting rods	-	-	-
Needle bearing	-	-	-
Main bearing	-	-	-

## TM® - 2 stroke



Model	250 Cross & Enduro Domed 1. Ring	300 Cross & Enduro	300 Cross & Enduro with exhaust bar
Years	99-14	97-01	08-09 / 02-11
Displ. (cc)	249	300	300

Piston Kit Part No.	Piston size (mm)	Over size (mm)	Ring Set Part No.	Piston Kit Part No.	Piston size (mm)	Over size (mm)	Ring Set Part No.	Piston Kit Part No.	Piston size (mm)	Over size (mm)	Ring Set Part No.
8137DA	66,33	Std.	RSB6640	8054DA	71,93	Std.	RSB7200	8213DA	71,93	Std.	RSB7200
8137DB	66,34	+0,01	RSB6640	8054DB	71,94	+0,01	RSB7200	8213DB	71,94	+0,01	RSB7200
8137DC	66,35	+0,02	RSB6640	8054DC	71,95	+0,02	RSB7200	8213DC	71,95	+0,02	RSB7200
8137DD	66,36	+0,03	RSB6640								

	set includes		
Clip Part No.	CW18	CW18	CW18
Pin Part No.	WP033	WP033	WP033
Rings	included	included	included
Price-Code	3/1	6/1	6/1
Stroke	72	73.7	73.7
Comp. Height (mm)	38	37	38

	extra parts		
Top End Gasket Kit	-	-	-
Wössner Connecting rods	-	-	-
Needle bearing	-	-	-
Main bearing	-	-	-

## TM® - 4 stroke



Verdichtungen beziehen sich auf Standardmaße „-DA“  
 Compression ratio refer to standard sizes “-DA”

Model	250 F Cross & Enduro	250 F Cross & Enduro Fuel injection
Years	07-10	10
Displ. (cc)	249	250

Piston Kit Part No.	Piston size (mm)	Over size (mm)	Ring Set Part No.	Piston Kit Part No.	Piston size (mm)	Over size (mm)	Ring Set Part No.
8653DA	76,96	Std.	770XAS-2	8826DA	76,96	Std.	770XAS-2
8653DB	76,97	+0,01	770XAS-2	8826DB	76,97	+0,01	770XAS-2
8653DC	76,98	+0,02	770XAS-2	8826DC	76,98	+0,02	770XAS-2

set includes		
Clip Part No.	CW16	CW16
Pin Part No.	WP059	WP059
Rings	included	included
Price-Code	5/1	5/1
Stroke	53.6	53.7
Wössner/ OEM Comp. ratio	- 15:1	- 16.7:1
Dome Volume (CC)	-1.3 cm <sup>3</sup>	-2.1 cm <sup>3</sup>
Comp. Height (mm)	22.40	19.3

extra parts		
Top End Gasket Kit	-	-
Wössner Connecting rods	-	-
Needle bearing	-	-
Main bearing	-	-

## TM® - 4 stroke



Verdichtungen beziehen sich auf Standardmaße „-DA“

Compression ratio refer to standard sizes “-DA”

Model	MX250F / EN250F Fuel injection	450 Cross & Enduro	450 Cross & Enduro
Years	11-12	04	05-08
Displ. (cc)	250	449	449

Piston Kit Part No.	Piston size (mm)	Over size (mm)	Ring Set Part No.	Piston Kit Part No.	Piston size (mm)	Over size (mm)	Ring Set Part No.	Piston Kit Part No.	Piston size (mm)	Over size (mm)	Ring Set Part No.
8839DA	76,96	Std.	770XAS-2	8586DA	94,96	Std.	950XDS	8714DA	94,96	Std.	950ADS-2
8839DB	76,97	+0,01	770XAS-2	8586DB	94,97	+0,01	950XDS	8714DB	94,97	+0,01	950ADS-2
8839DC	76,98	+0,02	770XAS-2					8714DC	94,98	+0,02	950ADS-2

	set includes		
Clip Part No.	CW16	CW19	CW19
Pin Part No.	WP059	WP037	WP037
Rings	included	included	included
Price-Code	5/1	7/1	7/1
Stroke	53.6	63.4	63.4
Wössner/ OEM Comp. ratio	- 17.2:1	-	-
Dome Volume (CC)	-2.1 cm <sup>3</sup>	-7.1 cm <sup>3</sup>	-11.4 cm <sup>3</sup>
Comp. Height (mm)	22.2	25.50	25.50

	extra parts		
Top End Gasket Kit	-	-	-
Wössner Connecting rods	-	-	-
Needle bearing	-	-	-
Main bearing	-	-	-



## TM® - 4 stroke



Verdichtungen beziehen sich auf Standardmaße „-DA“  
 Compression ratio refer to standard sizes “-DA”

<b>Model</b>	MX-F450 / MX-Fi450 / EN-Fi450 Fuel injection from `11	530 Cross & Enduro
<b>Years</b>	09-10 / 11 / 11	03-12
<b>Displ. (cc)</b>	449	527

Piston Kit Part No.	Piston size (mm)	Over size (mm)	Ring Set Part No.	Piston Kit Part No.	Piston size (mm)	Over size (mm)	Ring Set Part No.
8820DA	94,96	Std.	950ADS-2	8654DA	97,95	Std.	980XSY
8820DB	94,97	+0,01	950ADS-2	8654DB	97,96	+0,01	980XSY
8820DC	94,98	+0,02	950ADS-2				

set includes		
<b>Clip Part No.</b>	CW19	CW20
<b>Pin Part No.</b>	WP037	WP038
<b>Rings</b>	included	included
<b>Price-Code</b>	7/1	7/1
<b>Stroke</b>	63.4	70
<b>Wössner/ OEM Comp. ratio</b>	13:1 13:1	- 11.9:1
<b>Dome Volume (CC)</b>	-6.4 cm <sup>3</sup>	-13.7 cm <sup>3</sup>
<b>Comp. Height (mm)</b>	21	26.80

extra parts		
<b>Top End Gasket Kit</b>	-	-
<b>Wössner Connecting rods</b>	-	-
<b>Needle bearing</b>	-	-
<b>Main bearing</b>	-	-

## VOR® - 4 stroke



Verdichtungen beziehen sich auf Standardmaße „-DA“  
 Compression ratio refer to standard sizes “-DA”

Model	450 Cross & Enduro	503 Cross & Enduro	530 Cross & Enduro
Years	04-07	00-02	02-07
Displ. (cc)	444	503	444

Piston Kit Part No.	Piston size (mm)	Over size (mm)	Ring Set Part No.	Piston Kit Part No.	Piston size (mm)	Over size (mm)	Ring Set Part No.	Piston Kit Part No.	Piston size (mm)	Over size (mm)	Ring Set Part No.
8589DB	96,95	+0,01	970XSY	8554DA	94,94	Std.	950XSY	8555DA	96,94	Std.	970XSY
8589DC	96,96	+0,02	970XSY	8554DB	94,95	+0,01	950XSY	8555DB	96,95	+0,01	970XSY
				8554DC	94,96	+0,02	950XSY	8555DC	96,96	+0,02	970XSY

set includes			
Clip Part No.	CW20	CW20	CW20
Pin Part No.	WP038	WP038	WP038
Rings	included	included	included
Price-Code	7/1	7/1	7/1
Stroke	60	71	60.1
Wössner/ OEM Comp. ratio	- 12:1	- 11.8:1	- 12.1:1
Dome Volume (CC)	+9.8 cm <sup>3</sup>	+2.4 cm <sup>3</sup>	+4.2 cm <sup>3</sup>
Comp. Height (mm)	21.80	22	22

extra parts			
Top End Gasket Kit	-	-	-
Wössner Connecting rods	-	-	-
Needle bearing	-	-	-
Main bearing	-	-	-

## Yamaha® - 2 stroke



Model	YSR50	PW50	PW80 / BW80
Years	thru 92	81-14	thru 06 / 86-88 & 90
Displ. (cc)	-	-	-

Piston Kit Part No.	Piston size (mm)	Over size (mm)	Ring Set Part No.	Piston Kit Part No.	Piston size (mm)	Over size (mm)	Ring Set Part No.	Piston Kit Part No.	Piston size (mm)	Over size (mm)	Ring Set Part No.
8268DA	39,95	Std.	RDB4000	8267DA	39,95	Std.	RSB4000	8233DA	46,95	Std.	RSB4700
8268D050	40,45	+0,50	RDB4050	8267D050	40,45	+0,50	RSB4050	8233D050	47,45	+0,50	RSB4750
8268D100	40,95	+1,00	RDB4100	8267D100	40,95	+1,00	RSB4100	8233D100	47,95	+1,00	RSB4800
8268D150	41,45	+1,50	RDB4150	8267D150	41,45	+1,50	RSB4150	8233D150	48,45	+1,50	RSB4850
8268D200	41,95	+2,00	RDB4200	8267D200	41,95	+2,00	RSB4200	8233D200	48,95	+2,00	RSB4900
8268D250	42,45	+2,50	RDB4250								
8268D300	42,95	+3,00	RDB4300								

	set includes		
Clip Part No.	CW12	CW10	CW12
Pin Part No.	WP101	WP105	WP091
Rings	included	included	included
Price-Code	1	1	1/1
Stroke	39	39.2	45.6
Comp. Height (mm)	23.3	24.9	29.50

	extra parts		
Top End Gasket Kit	-	-	-
Wössner Connecting rods	-	-	-
Needle bearing	-	-	N1037
Main bearing	-	2 x MB6203C3	2 x MB6205C3

## Yamaha® - 2 stroke



Model	YZ80	YZ80	YZ80
Years	76-80	81	82-83
Displ. (cc)	79	79	79

Piston Kit Part No.	Piston size (mm)	Over size (mm)	Ring Set Part No.	Piston Kit Part No.	Piston size (mm)	Over size (mm)	Ring Set Part No.	Piston Kit Part No.	Piston size (mm)	Over size (mm)	Ring Set Part No.
8183DA	48,95	Std.	RSB4900	8184DA	48,95	Std.	RSB4900	8185DA	46,95	Std.	RSB4700
8183D050	49,45	+0,50	RSB4950	8184D050	49,45	+0,50	RSB4950	8185D050	47,45	+0,50	RSB4750
8183D100	49,95	+1,00	RSB5000	8184D100	49,95	+1,00	RSB5000	8185D100	47,95	+1,00	RSB4800
8183D150	50,45	+1,50	RSB5050	8184D150	50,45	+1,50	RSB5050	8185D150	48,45	+1,50	RSB4850
8183D200	50,95	+2,00	RSB5100	8184D200	50,95	+2,00	RSB5100	8185D200	48,95	+2,00	RSB4900

	set includes		
Clip Part No.	CW12	CW12	CW12
Pin Part No.	WP091	WP091	WP091
Rings	included	included	included
Price-Code	1/1	1/1	1/1
Stroke	42	42	45.6
Comp. Height (mm)	29.5	24.2	27.2

	extra parts		
Top End Gasket Kit	-	-	-
Wössner Connecting rods	-	-	-
Needle bearing	N1037	N1002	N1002
Main bearing	-	-	2 x MB6204C3

## Yamaha® - 2 stroke



Model	YZ80	YZ80	YZ80
Years	84	85-87	88-92
Displ. (cc)	82	82	82

Piston Kit Part No.	Piston size (mm)	Over size (mm)	Ring Set Part No.	Piston Kit Part No.	Piston size (mm)	Over size (mm)	Ring Set Part No.	Piston Kit Part No.	Piston size (mm)	Over size (mm)	Ring Set Part No.
8214DA	47,95	Std.	RSB4800	8186DA	47,95	Std.	RSB4800	8187DA	47,95	Std.	RSB4800
8214D050	48,45	+0,50	RSB4850	8186D050	48,45	+0,50	RSB4850	8187D050	48,45	+0,50	RSB4850
8214D100	48,95	+1,00	RSB4900	8186D100	48,95	+1,00	RSB4900	8187D100	48,95	+1,00	RSB4900
8214D150	49,45	+1,50	RSB4950	8186D150	49,45	+1,50	RSB4950	8187D150	49,45	+1,50	RSB4950
8214D200	49,95	+2,00	RSB5000	8186D200	49,95	+2,00	RSB5000	8187D200	49,95	+2,00	RSB5000

	set includes		
Clip Part No.	CW12	CW12	CW12
Pin Part No.	WP091	WP091	WP091
Rings	included	included	included
Price-Code	1/1	1	1/1
Stroke	45.6	45.6	45.6
Comp. Height (mm)	27	26.8	27

	extra parts		
Top End Gasket Kit	-	-	-
Wössner Connecting rods	-	-	-
Needle bearing	N1004	N1004	N1004
Main bearing	2 x MB6204C3	2 x MB6204C3	2 x MB6204C3

## Yamaha® - 2 stroke



Model	YZ80 U.S. Bore	YZ80 International Bore	MX80 / TY80 / YZ80 / GT1
Years	93-01	93-01	80-82 / 74-75 / 73-75
Displ. (cc)	82	82	-

Piston Kit Part No.	Piston size (mm)	Over size (mm)	Ring Set Part No.	Piston Kit Part No.	Piston size (mm)	Over size (mm)	Ring Set Part No.	Piston Kit Part No.	Piston size (mm)	Over size (mm)	Ring Set Part No.
8188DA	46,95	Std.	RSB4700	8239DA	45,95	Std.	RSB4600	8269DA	46,95	Std.	RSB4700
8188DB	46,96	+0,01	RSB4700	8239D050	46,45	+0,50	RSB4650	8269D150	48,45	+1,50	RSB4850
8188DC	46,97	+0,02	RSB4700	8239D100	46,95	+1,00	RSB4700	8269D200	48,95	+2,00	RSB4900
8188DD	46,98	+0,03	RSB4700	8239D150	47,45	+1,50	RSB4750				
8188D050	47,45	+0,50	RSB4750								
8188D100	47,95	+1,00	RSB4800								
8188D150	48,45	+1,50	RSB4850								
8188D200	48,95	+2,00	RSB4900								

	set includes		
Clip Part No.	CW14	CW14	CW12
Pin Part No.	WP058	WP058	WP091
Rings	included	included	included
Price-Code	1/1	1	1
Stroke	47.8	47.8	42
Comp. Height (mm)	26	26	29.4

	extra parts		
Top End Gasket Kit	-	-	-
Wössner Connecting rods	P2008	P2008	-
Needle bearing	N1006	N1006	N1037
Main bearing	1 x MB6204C3 `Left 1 x MB6304C3 `Right	1 x MB6204C3 `Left 1 x MB6304C3 `Right	-

## Yamaha® - 2 stroke



Model	YZ85	125DTE / 125DTF / 125DTMX / 125DTLC	DT125R / DT125 E / DT125X (domed)
Years	02-14	75-92	91-06
Displ. (cc)	85	124	124

Piston Kit Part No.	Piston size (mm)	Over size (mm)	Ring Set Part No.	Piston Kit Part No.	Piston size (mm)	Over size (mm)	Ring Set Part No.	Piston Kit Part No.	Piston size (mm)	Over size (mm)	Ring Set Part No.
8104DA	47,45	Std.	RSB4750	8003DA	55,94	Std.	RDB5600	8002DA	55,94	Std.	RDB5600
8104DB	47,46	+0,01	RSB4750	8003D025	56,19	+0,25	RDB5625	8002D025	56,19	+0,25	RDB5625
8104DC	47,47	+0,02	RSB4750	8003D050	56,44	+0,50	RDB5650	8002D050	56,44	+0,50	RDB5650
				8003D075	56,69	+0,75	RDB5675	8002D075	56,69	+0,75	RDB5675
				8003D100	56,94	+1,00	RDB5700	8002D100	56,94	+1,00	RDB5700
				8003D125	57,19	+1,25	RDB5725	8002D125	57,19	+1,25	RDB5725
				8003D150	57,44	+1,50	RDB5750	8002D150	57,44	+1,50	RDB5750
								8002D200	57,94	+2,00	RDB5800
								8002D250	58,44	+2,50	RDB5850
								8002D300	58,94	+3,00	RDB5900
								8002D400	59,94	+4,00	RDB6000
								8002D500	60,94	+5,00	RDB6100

	set includes		
Clip Part No.	CW14	CW16	CW16
Pin Part No.	WP058	WP036	WP036
Rings	included	included	included
Price-Code	1	2	2
Stroke	47.8	50.7	50.7
Comp. Height (mm)	26	29.90	29.90

	extra parts		
Top End Gasket Kit	D2034-EST	-	D2035-EST
Wössner Connecting rods	P2008 `02-14	-	P2050
Needle bearing	N1006	N1016	N1016
Main bearing	1 x MB6204C3 `Left 1 x MB6304C3 `Right	-	-

## Yamaha® - 2 stroke



Model	TZR125R / TDR125 Flat top	YZ125	YZ125
Years	92-98	76-82	83
Displ. (cc)	124	123	123

Piston Kit Part No.	Piston size (mm)	Over size (mm)	Ring Set Part No.	Piston Kit Part No.	Piston size (mm)	Over size (mm)	Ring Set Part No.	Piston Kit Part No.	Piston size (mm)	Over size (mm)	Ring Set Part No.
8006DA	55,94	Std.	RDB5600	8115DA	55,94	Std.	RSB5600	8119DA	55,94	Std.	RSB5600
8006DB	55,95	+0,01	RDB5600	8115D050	56,44	+0,50	RSB5650	8119D050	56,44	+0,50	RSB5650
8006DC	55,96	+0,02	RDB5600	8115D100	56,94	+1,00	RSB5700	8119D100	56,94	+1,00	RSB5700
8006D050	56,44	+0,50	RDB5650	8115D150	57,44	+1,50	RSB5750	8119D150	57,44	+1,50	RSB5750
8006D100	56,94	+1,00	RDB5700	8115D200	57,94	+2,00	RSB5800	8119D200	57,94	+2,00	RSB5800
8006D150	57,44	+1,50	RDB5750								
8006D175	57,69	+1,75	RDB5775								
8006D200	57,94	+2,00	RDB5800								

set includes			
Clip Part No.	CW16	CW16	CW16
Pin Part No.	WP036	WP036	WP036
Rings	included	included	included
Price-Code	2	2/1	2/1
Stroke	50.7	50	50
Comp. Height (mm)	29.90	30	30.80

extra parts			
Top End Gasket Kit	-	-	-
Wössner Connecting rods	P2050	-	-
Needle bearing	N1016	N1013	N1013
Main bearing	-	-	1 x MB6205C3 `Left 1 x MB6304C3 `Right



## Yamaha® - 2 stroke



Model	YZ125	YZ125	YZ125
Years	84	85	86-88
Displ. (cc)	123	123	123

Piston Kit Part No.	Piston size (mm)	Over size (mm)	Ring Set Part No.	Piston Kit Part No.	Piston size (mm)	Over size (mm)	Ring Set Part No.	Piston Kit Part No.	Piston size (mm)	Over size (mm)	Ring Set Part No.
8120DA	55,94	Std.	RSB5600	8119DA	55,94	Std.	RSB5600	8118DA	55,94	Std.	RSB5600
8120D050	56,44	+0,50	RSB5650	8119D050	56,44	+0,50	RSB5650	8118D050	56,44	+0,50	RSB5650
8120D100	56,94	+1,00	RSB5700	8119D100	56,94	+1,00	RSB5700	8118D075	56,69	+0,75	RSB5675
8120D150	57,44	+1,50	RSB5750	8119D150	57,44	+1,50	RSB5750	8118D100	56,94	+1,00	RSB5700
8120D200	57,94	+2,00	RSB5800	8119D200	57,94	+2,00	RSB5800	8118D125	57,19	+1,25	RSB5725
								8118D150	57,44	+1,50	RSB5750
								8118D200	57,94	+2,00	RSB5800

	set includes		
Clip Part No.	CW16	CW16	CW16
Pin Part No.	WP036	WP036	WP036
Rings	included	included	included
Price-Code	2/1	2/1	2/1
Stroke	50	50	50
Comp. Height (mm)	30.80	30.80	30

	extra parts		
Top End Gasket Kit	-	-	-
Wössner Connecting rods	-	-	P2047
Needle bearing	N1013	N1013	N1013
Main bearing	1 x MB6205C3 `Left 1 x MB6304C3 `Right	1 x MB6205C3 `Left 1 x MB6304C3 `Right	2 x MB6322C4

## Yamaha® - 2 stroke



<b>Model</b>	YZ125	YZ125	YZ125
<b>Years</b>	89	90-93	94-96
<b>Displ. (cc)</b>	123	124	124

Piston Kit Part No.	Piston size (mm)	Over size (mm)	Ring Set Part No.	Piston Kit Part No.	Piston size (mm)	Over size (mm)	Ring Set Part No.	Piston Kit Part No.	Piston size (mm)	Over size (mm)	Ring Set Part No.
8131DA	55,94	Std.	RSB5600	8114DA	55,94	Std.	RSB5600	8116DA	53,94	Std.	RSB5400
8131DB	55,95	+0,01	RSB5600	8114DB	55,95	+0,01	RSB5600	8116DB	53,95	+0,01	RSB5400
8131D050	56,44	+0,50	RSB5650	8114DC	55,96	+0,02	RSB5600	8116D050	54,44	+0,50	RSB5450
8131D100	56,94	+1,00	RSB5700	8114D050	56,44	+0,50	RSB5650	8116D100	54,94	+1,00	RSB5500
				8114D100	56,94	+1,00	RSB5700	8116D200	55,94	+2,00	RSB5600
				8114D150	57,44	+1,50	RSB5750				
				8114D200	57,94	+2,00	RSB5800				

set includes			
<b>Clip Part No.</b>	CW16	CW16	CW16
<b>Pin Part No.</b>	WP036	WP036	WP036
<b>Rings</b>	included	included	included
<b>Price-Code</b>	2	2	2
<b>Stroke</b>	50	50.7	54.5
<b>Comp. Height (mm)</b>	28	28	28

extra parts			
<b>Top End Gasket Kit</b>	-	-	D2037-EST
<b>Wössner Connecting rods</b>	P2047	P2047	P2047
<b>Needle bearing</b>	N1013	N1013	N1013
<b>Main bearing</b>	2 x MB6322C4	2 x MB6322C4	2 x MB6322C4

## Yamaha® - 2 stroke



<b>Model</b>	YZ125	YZ125 / WR125	YZ125
<b>Years</b>	97	98-01	02-04
<b>Displ. (cc)</b>	124	125	125

Piston Kit Part No.	Piston size (mm)	Over size (mm)	Ring Set Part No.	Piston Kit Part No.	Piston size (mm)	Over size (mm)	Ring Set Part No.	Piston Kit Part No.	Piston size (mm)	Over size (mm)	Ring Set Part No.
8117DA	53,94	Std.	RSB5400	8091DA	53,95	Std.	RSB5400	8072DA	53,94	Std.	RSB5400
8117DB	53,95	+0,01	RSB5400	8091DB	53,96	+0,01	RSB5400	8072DB	53,95	+0,01	RSB5400
8117DC	53,96	+0,02	RSB5400	8091DC	53,97	+0,02	RSB5400	8072DC	53,96	+0,02	RSB5400
8117D200	55,94	+2,00	RSB5600	8091D050	54,45	+0,50	RSB5450	8072D200	55,94	+2,00	RSB5600
				8091D100	54,95	+1,00	RSB5500				
				8091D200	55,95	+2,00	RSB5600				

set includes			
<b>Clip Part No.</b>	CW15	CW15	CW15
<b>Pin Part No.</b>	WP032	WP032	WP032
<b>Rings</b>	included	included	included
<b>Price-Code</b>	2/1	2	2
<b>Stroke</b>	54.5	54.5	54.5
<b>Comp. Height (mm)</b>	28	28	28

extra parts			
<b>Top End Gasket Kit</b>	D2037-EST	D2037-EST / D2038-EST	D2038-EST
<b>Wössner Connecting rods</b>	P2019	P2019 `97-00 P2017 `01-04	P2017
<b>Needle bearing</b>	N1011	N1011	N1043 replaced by N1047
<b>Main bearing</b>	2 x MB6322C4	2 x MB6322C4	2 x MB6322C4

## Yamaha® - 2 stroke



Model	YZ125	DT200R	WR200
Years	05-14	88-91	92-98
Displ. (cc)	125	195	195

Piston Kit Part No.	Piston size (mm)	Over size (mm)	Ring Set Part No.	Piston Kit Part No.	Piston size (mm)	Over size (mm)	Ring Set Part No.	Piston Kit Part No.	Piston size (mm)	Over size (mm)	Ring Set Part No.
8160DA	53,95	Std.	RSB5400	8070DA	65,94	Std.	RDB6600	8070D080	66,74	Std.	RDB6675
8160DB	53,96	+0,01	RSB5400	8070D040	66,34	+0,40	RDB6640	8070D100	66,94	+0,20	RDB6700
8160DC	53,97	+0,02	RSB5400	8070D050	65,44	+0,50	RDB6650	8070D150	67,44	+0,70	RDB6750
8160D200	55,95	+2,00	RSB5600	8070D080	66,74	+0,80	RDB6675	8070D200	67,94	+1,30	RDB6800
8160D400	57,95	+4,00	RSB5800	8070D100	66,94	+1,00	RDB6700	8070D250	68,44	+1,80	RDB6850
				8070D150	67,44	+1,50	RDB6750	8070D300	68,94	+2,30	RDB6900
				8070D200	67,94	+2,00	RDB6800				
				8070D250	68,44	+2,50	RDB6850				
				8070D300	68,94	+3,00	RDB6900				
				8070D600	71,94	+6,00	RDB7200				
				8070D650	72,44	+6,50	RDB7250				
				8070D700	72,94	+7,00	RDB7300				
				8070D800	73,94	+8,00	RDB7400				

	set includes		
Clip Part No.	CW15	CW16	CW16
Pin Part No.	WP032	WP027	WP027
Rings	included	included	included
Price-Code	2	3	3
Stroke	54.5	57	57
Comp. Height (mm)	28	29.90	29.90

	extra parts		
Top End Gasket Kit	D2039-EST	D2052-EST	D2052-EST
Wössner Connecting rods	P2018 '05-14	-	-
Needle bearing	N1047	N1016	N1016
Main bearing	2 x MB6322C4	-	-

## Yamaha® - 2 stroke



Model	YZ250 / IT250 / TY250 / MC250 / DT250	YZ250 / IT250	YZ250
Years	76-79 / 78-80 / 74-78 / 73-75 / 74-79	80-82 / 81-82	83-87
Displ. (cc)	246	246	246

Piston Kit Part No.	Piston size (mm)	Over size (mm)	Ring Set Part No.	Piston Kit Part No.	Piston size (mm)	Over size (mm)	Ring Set Part No.	Piston Kit Part No.	Piston size (mm)	Over size (mm)	Ring Set Part No.
8179DA	69,94	Std.	RDB7000	8180DA	69,94	Std.	RDB7000	8133DA	67,94	Std.	RDB6800
8179D050	70,44	+0,50	RDB7050	8180D025	70,19	+0,25	RDB7025	8133D025	68,19	+0,25	RDB6825
8179D100	70,94	+1,00	RDB7100	8180D050	70,44	+0,50	RDB7050	8133D050	68,44	+0,50	RDB6850
8179D150	71,44	+1,50	RDB7150	8180D075	70,69	+0,75	RDB7075	8133D075	68,69	+0,75	RDB6875
8179D200	71,94	+2,00	RDB7200	8180D100	70,94	+1,00	RDB7100	8133D100	68,94	+1,00	RDB6900
				8180D150	71,44	+1,50	RDB7150	8133D125	69,19	+1,25	RDB6925
				8180D200	71,94	+2,00	RDB7200	8133D150	69,44	+1,50	RDB6950
								8133D200	69,94	+2,00	RDB7000

	set includes		
Clip Part No.	CW18	CW18	CW18
Pin Part No.	WP033	WP033	WP033
Rings	included	included	included
Price-Code	3/1	3/1	3/1
Stroke	64	64	68
Comp. Height (mm)	33	33	36

	extra parts		
Top End Gasket Kit	-	-	-
Wössner Connecting rods	-	-	P2048 `83-89
Needle bearing	N1021	N1021 `76-82 N1022 `82-98	N1022
Main bearing	-	-	2 x MB6206C3

## Yamaha® - 2 stroke



Model	YZ250 / WR250	YZ250 / WR250	YZ250
Years	88-91	92-98 / 92-99	99-14
Displ. (cc)	246	246	249

Piston Kit Part No.	Piston size (mm)	Over size (mm)	Ring Set Part No.	Piston Kit Part No.	Piston size (mm)	Over size (mm)	Ring Set Part No.	Piston Kit Part No.	Piston size (mm)	Over size (mm)	Ring Set Part No.
8134DA	67,94	Std.	RDB6800	8023DA	67,94	Std.	RDB6800	8216DA	66,35	Std.	RDB6640
8134DB	67,95	+0,01	RDB6800	8023DB	67,95	+0,01	RDB6800	8216DB	66,36	+0,01	RDB6640
8134D025	68,19	+0,25	RDB6825	8023DC	67,96	+0,02	RDB6800	8216DC	66,37	+0,02	RDB6640
8134D050	68,44	+0,50	RDB6850	8023D050	68,44	+0,50	RDB6850				
8134D100	68,94	+1,00	RDB6900	8023D100	68,94	+1,00	RDB6900				
8134D125	69,19	+1,25	RDB6925	8023D200	69,94	+2,00	RDB7000				
8134D150	69,44	+1,50	RDB6950								
8134D200	69,94	+2,00	RDB7000								

set includes			
Clip Part No.	CW18	CW18	CW18
Pin Part No.	WP033	WP033	WP033
Rings	included	included	included
Price-Code	3/1	3	3
Stroke	68	68	68
Comp. Height (mm)	36	36	38

extra parts			
Top End Gasket Kit	D2040-EST	D2040-EST `88-96 (YZ250) D2041-EST `99-10 (YZ250) D2040-EST `88-97 (WR250)	D2041-EST `99-10
Wössner Connecting rods	P2048 `83-89 P2029 `90-98	P2029 `90-98 P2028 `99-14	P2028 `99-14
Needle bearing	N1022	N1022	N1021
Main bearing	2 x MB6328C3	2 x MB6328C3	2 x MB6328C3

## Yamaha® - 2 stroke



<b>Model</b>	YZ250 Single Ring	175CT-2 / 175CT / 175DT / 175MX	DT175
<b>Years</b>	99-14	Thru 77 / Thru 77 / 79-81 / 79-82	82-10
<b>Displ. (cc)</b>	249	172	171

Piston Kit Part No.	Piston size (mm)	Over size (mm)	Ring Set Part No.	Piston Kit Part No.	Piston size (mm)	Over size (mm)	Ring Set Part No.	Piston Kit Part No.	Piston size (mm)	Over size (mm)	Ring Set Part No.
8217DA	66,35	Std.	RSB6640	8182DA	65,94	Std.	RDB6600	8256DA	65,94	Std.	RDB6600
8217DB	66,36	+0,01	RSB6640	8182D050	66,44	+0,50	RDB6650	8256D050	66,44	+0,50	RDB6650
8217DC	66,37	+0,02	RSB6640	8182D100	66,94	+1,00	RDB6700	8256D100	66,94	+1,00	RDB6700
				8182D150	67,44	+1,50	RDB6750	8256D150	67,44	+1,50	RDB6750
				8182D200	67,94	+2,00	RDB6800	8256D200	67,94	+2,00	RDB6800

	set includes		
<b>Clip Part No.</b>	CW18	CW16	CW16
<b>Pin Part No.</b>	WP033	WP027	WP027
<b>Rings</b>	included	included	included
<b>Price-Code</b>	3/1	3/1	3/1
<b>Stroke</b>	68	50	50
<b>Comp. Height (mm)</b>	38	30	35

	extra parts		
<b>Top End Gasket Kit</b>	D2041-EST	-	-
<b>Wössner Connecting rods</b>	P2028 '99-14	-	-
<b>Needle bearing</b>	N1021	-	-
<b>Main bearing</b>	2 x MB6328C3	-	-

## Yamaha® - 2 stroke



Model	YZ175 / IT175	IT200	RD400 / RD350
Years	76-81	84-86	76-82 / 73-90
Displ. (cc)	172	195	347

Piston Kit Part No.	Piston size (mm)	Over size (mm)	Ring Set Part No.	Piston Kit Part No.	Piston size (mm)	Over size (mm)	Ring Set Part No.	Piston Kit Part No.	Piston size (mm)	Over size (mm)	Ring Set Part No.
8177DA	65,94	Std.	RDB6600	8176DA	65,94	Std.	RDB6600	8075DA	63,94	Std.	RDB6400
8177D050	66,44	+0,50	RDB6650	8176D050	66,44	+0,50	RDB6650	8075DB	63,95	+0,01	RDB6400
8177D100	66,94	+1,00	RDB6700	8176D100	66,94	+1,00	RDB6700	8075D025	64,19	+0,25	RDB6425
8177D150	67,44	+1,50	RDB6750	8176D150	67,44	+1,50	RDB6750	8075D050	64,44	+0,50	RDB6450
8177D200	67,94	+2,00	RDB6800	8176D200	67,94	+2,00	RDB6800	8075D075	64,69	+0,75	RDB6475
								8075D100	64,94	+1,00	RDB6500
								8075D125	65,19	+1,25	RDB6525
								8075D150	65,44	+1,50	RDB6550
								8075D200	65,94	+2,00	RDB6600
								8075D250	66,44	+2,50	RDB6650

set includes			
Clip Part No.	CW16	CW16	CW16
Pin Part No.	WP027	WP027	WP027
Rings	included	included	included
Price-Code	3/1	3/1	8
Stroke	50	57	54
Comp. Height (mm)	30	30	36

extra parts			
Top End Gasket Kit	-	-	D2068-EST D2069-EST
Wössner Connecting rods	-	-	P2035 `87-06
Needle bearing	-	N1017	N1017
Main bearing	-	-	-



## Yamaha® - 2 stroke



<b>Model</b>	350 R5	DT400 / MX400
<b>Years</b>	73-75	75-78 / 75-76
<b>Displ. (cc)</b>	347	398

Piston Kit Part No.	Piston size (mm)	Over size (mm)	Ring Set Part No.	Piston Kit Part No.	Piston size (mm)	Over size (mm)	Ring Set Part No.
8221DA	63,93	Std.	RDB6400	8263DA	84,92	Std.	RDC8500
8221D050	64,43	+0,50	RDB6450	8263D050	85,42	+0,50	RDC8550
8221D075	64,68	+0,75	RDB6475	8263D100	85,92	+1,00	RDC8600
8221D100	64,93	+1,00	RDB6500	8263D150	86,42	+1,50	RDC8650
8221D125	65,18	+1,25	RDB6525				
8221D150	65,43	+1,50	RDB6550				
8221D200	65,93	+2,00	RDB6600				

set includes		
<b>Clip Part No.</b>	CW16	CW18
<b>Pin Part No.</b>	WP027	WP042
<b>Rings</b>	included	included
<b>Price-Code</b>	8	6
<b>Stroke</b>	54	70
<b>Comp. Height (mm)</b>	36	40

extra parts		
<b>Top End Gasket Kit</b>	-	-
<b>Wössner Connecting rods</b>	P2035	-
<b>Needle bearing</b>	N1017	N1021
<b>Main bearing</b>	-	-

## Yamaha® - 2 stroke



Model	YZ400 / IT425	YZ465 / IT465	YZ490 / IT490
Years	77-78	81-82 / 80-81	82-83 / 83-84
Displ. (cc)	398	465	465

Piston Kit Part No.	Piston size (mm)	Over size (mm)	Ring Set Part No.	Piston Kit Part No.	Piston size (mm)	Over size (mm)	Ring Set Part No.	Piston Kit Part No.	Piston size (mm)	Over size (mm)	Ring Set Part No.
8264D100	85,92	+1,00	RDC8600	8265DA	84,92	Std.	RDC8500	8266DA	86,92	Std.	RDC8700
8264D150	86,42	+1,50	RDC8650	8265D050	85,42	+0,50	RDC8550	8266D050	87,42	+0,50	RDC8750
8264D200	86,92	+2,00	RDC8700	8265D100	85,92	+1,00	RDC8600	8266D100	87,92	+1,00	RDC8800
				8265D150	86,42	+1,50	RDC8650	8266D150	88,42	+1,50	RDC8850
								8266D200	88,92	+2,00	RDC8900

	set includes		
Clip Part No.	CW18	CW18	CW18
Pin Part No.	WP042	WP042	WP042
Rings	included	included	included
Price-Code	6	6	6
Stroke	70	82	82
Comp. Height (mm)	35	40	40

	extra parts		
Top End Gasket Kit	-	-	-
Wössner Connecting rods	-	-	-
Needle bearing	N1021	N1022	N1022
Main bearing	-	-	-

## Yamaha® - 4 stroke



Verdichtungen beziehen sich auf Standardmaße „-DA“  
 Compression ratio refer to standard sizes “-DA”

Model	XT125	TTR125 / XT125X / XT125XR / YBR125	YZ250F / WR250F Pro Serie 2. Ring
Years	all	01-13	01-04
Displ. (cc)	124	124	249

Piston Kit Part No.	Piston size (mm)	Over size (mm)	Ring Set Part No.	Piston Kit Part No.	Piston size (mm)	Over size (mm)	Ring Set Part No.	Piston Kit Part No.	Piston size (mm)	Over size (mm)	Ring Set Part No.
8553DA	59,95	Std.	600XKS	8649DA	53,94	Std.	540XKS	8572DA	76,96	Std.	770XAS-2
8553D500	64,95	+5,00	650XKS	8649D050	54,44	+0,50	545XKS	8572DB	76,97	+0,01	770XAS-2
				8649D100	54,94	+1,00	550XKS	8572DC	76,98	+0,02	770XAS-2
D200/D300 different dome volume (cc)											
								8572D200	78,96	+2,00	790XMS
								8572D300	79,96	+3,00	800XDS
D600 different dome volume (cc)											
								8572D600	82,96	+6,00	830XSY

	set includes		
Clip Part No.	CW15	CW15	CW16
Pin Part No.	WP011	WP011	WP059
Rings	included	included	included
Price-Code	4/1	4/1	4/1
Stroke	43.9	54	53.6
Wössner/ OEM Comp. ratio	- 10:1	10.3:1 10.3:1	12.8:1 12.5:1
Dome Volume (CC)	+4.8 cm <sup>3</sup>	+4.1 cm <sup>3</sup>	-4.80 cm <sup>3</sup> = DA - DC -5.90 cm <sup>3</sup> = D200 - D300 -8.20 cm <sup>3</sup> = D600
Comp. Height (mm)	24	20.20	20.50

	extra parts		
Top End Gasket Kit	-	-	D4029-EST
Wössner Connecting rods	-	-	P4006 `01-02 P4005 `03-13
Needle bearing	-	-	-
Main bearing	-	-	2 x MB830046-1

## Yamaha® - 4 stroke



Verdichtungen beziehen sich auf Standardmaße „-DA“

Compression ratio refer to standard sizes “-DA”

Model	YZ250F / WR250F 3. Ring	YZ250F / WR250F Pro Series 2. Ring	YZ250F / WR250F 3. Ring
Years	01-04 / 01-04	05-07	05-07
Displ. (cc)	249	249	249

Piston Kit Part No.	Piston size (mm)	Over size (mm)	Ring Set Part No.	Piston Kit Part No.	Piston size (mm)	Over size (mm)	Ring Set Part No.	Piston Kit Part No.	Piston size (mm)	Over size (mm)	Ring Set Part No.
8559DA	76,96	Std.	770XAS-2	8612DA	76,96	Std.	770XAS-2	8614DA	76,96	Std.	770XAS-2
8559DB	76,97	+0,01	770XAS-2	8612DB	76,97	+0,01	770XAS-2	8614DB	76,97	+0,01	770XAS-2
8559DC	76,98	+0,02	770XAS-2	8612DC	76,98	+0,02	770XAS-2	8614DC	76,98	+0,02	770XAS-2
8559D200	78,96	+2,00	790XMS					8614D200	78,96	+2,00	790XMS

	set includes		
Clip Part No.	CW16	CW16	CW16
Pin Part No.	WP059	WP059	WP059
Rings	included	included	included
Price-Code	4/1	5/1	5
Stroke	53.6	53.6	53.6
Wössner/ OEM Comp. ratio	12.5:1 12.5:1	13.5:1 12.5:1	12.5:1 12.5:1
Dome Volume (CC)	-4.7 cm <sup>3</sup>	-2.8 cm <sup>3</sup>	-4.5 cm <sup>3</sup>
Comp. Height (mm)	22.20	22.20	22.20

	extra parts		
Top End Gasket Kit	D4029-EST	D4029-EST	D4029-EST
Wössner Connecting rods	P4006 `01-02 P4005 `03-13	P4005 `03-13	P4005 `03-13
Needle bearing	-	-	-
Main bearing	2 x MB830046-1	2 x MB830046-1	2 x MB830046-1

## Yamaha® - 4 stroke



Verdichtungen beziehen sich auf Standardmaße „-DA“  
 Compression ratio refer to standard sizes “-DA”

**New!**

Model	YZ250F / WR250F 3. Ring	YZ250F / WR250F Pro Series - 2. Ring	YZF250
Years	08-13	08-13	14
Displ. (cc)	249	249	249

Piston Kit Part No.	Piston size (mm)	Over size (mm)	Ring Set Part No.	Piston Kit Part No.	Piston size (mm)	Over size (mm)	Ring Set Part No.	Piston Kit Part No.	Piston size (mm)	Over size (mm)	Ring Set Part No.
8712DA	76,96	Std.	770XAS-2	8713DA	76,96	Std.	770XAS-2	8893DA	76,95	Std.	770XAS-2
8712DB	76,97	+0,01	770XAS-2	8713DB	76,97	+0,01	770XAS-2	8893DB	76,96	+0,01	770XAS-2
8712DC	76,98	+0,02	770XAS-2	8713DC	76,98	+0,02	770XAS-2	8893DC	76,97	+0,02	770XAS-2
				8713D300	79,96	+3,00	800XDS				

	set includes		
Clip Part No.	CW16	CW16	CW16
Pin Part No.	WP059	WP070	WP087
Rings	included	included	included
Price-Code	5/1	5/1	5
Stroke	53.6	53.6	53.6
Wössner/ OEM Comp. ratio	13.5:1 13.5:1	14.1:1 13.5:1	13.7:1 13.5:1
Dome Volume (CC)	-2.9 cm <sup>3</sup>	-4.95 cm <sup>3</sup>	-3.04 cm <sup>3</sup>
Comp. Height (mm)	22.20	22.50	20.20

	extra parts		
Top End Gasket Kit	D4029-EST	D4029-EST	-
Wössner Connecting rods	P4005 `03-13	P4005 `03-13	P4063 `14
Needle bearing	-	-	-
Main bearing	2 x MB830046-1	2 x MB830046-1	-

## Yamaha® - 4 stroke



Verdichtungen beziehen sich auf Standardmaße „-DA“  
 Compression ratio refer to standard sizes “-DA”

**New!**

Model	YZF250 Pro Series	TTR250	WR250X
Years	14	99-09	08-14
Displ. (cc)	249	249	249

Piston Kit Part No.	Piston size (mm)	Over size (mm)	Ring Set Part No.	Piston Kit Part No.	Piston size (mm)	Over size (mm)	Ring Set Part No.	Piston Kit Part No.	Piston size (mm)	Over size (mm)	Ring Set Part No.
8894DA	76,95	Std.	770XAS-2	8646DA	72,95	Std.	730XDS	8729DA	76,96	Std.	770XAS-2
8894DB	76,96	+0,01	770XAS-2	8646D050	73,45	+0,50	735XDS	8729DB	76,97	+0,01	770XAS-2
8894DC	76,97	+0,02	770XAS-2	8646D100	73,95	+1,00	740XDS				
				8646D150	74,45	+1,50	745XDS				
				8646D200	74,95	+2,00	750XDS				

	set includes		
Clip Part No.	CW16	CW18	CW17
Pin Part No.	WP087	WP031	WP083
Rings	included	included	included
Price-Code	5	5/1	5/1
Stroke	53.6	59.6	53.6
Wössner/ OEM Comp. ratio	14.5:1 13.5:1	- 10.2:1	11.8:1 11.8:1
Dome Volume (CC)	-2.4 cm <sup>3</sup>	+1.4 cm <sup>3</sup>	-5.85 cm <sup>3</sup>
Comp. Height (mm)	20.50	23.6	22.9

	extra parts		
Top End Gasket Kit	-	-	-
Wössner Connecting rods	P4063 `14	-	-
Needle bearing	-	-	-
Main bearing	-	-	-

## Yamaha® - 4 stroke



Verdichtungen beziehen sich auf Standardmaße „-DA“

Compression ratio refer to standard sizes “-DA”

Model	WR250X Pro Series	TT350 / XT350	YZ400F / WR400F
Years	08-14	85-88 / 85-00	98-99
Displ. (cc)	249	346	399

Piston Kit Part No.	Piston size (mm)	Over size (mm)	Ring Set Part No.	Piston Kit Part No.	Piston size (mm)	Over size (mm)	Ring Set Part No.	Piston Kit Part No.	Piston size (mm)	Over size (mm)	Ring Set Part No.
8772DA	76,96	Std.	770XAS-2	8502DA	85,93	Std.	860XSY	8603DA	91,95	Std.	920XSY
8772DB	76,97	+0,01	770XAS-2	8502D050	86,43	+0,50	865XSY	8603DB	91,96	+0,01	920XSY
				8502D100	86,93	+1,00	870XSY	8603DC	91,97	+0,02	920XSY
				8502D150	87,43	+1,50	875XSY	8603D100	92,95	+1,00	930XSY
				8502D200	87,93	+2,00	880XSY	8603D200	93,95	+2,00	940XSY
				8502D250	88,43	+2,50	885XSY				

set includes			
Clip Part No.	CW17	CW19	CW18
Pin Part No.	WP083	WP050	WP053
Rings	included	included	included
Price-Code	5/1	5/1	7
Stroke	53.6	59.6	60.1
Wössner/ OEM Comp. ratio	13.5:1 11.8:1	- 9:1	12.5:1 12.5:1
Dome Volume (CC)	-2.9 cm <sup>3</sup>	-1.5 cm <sup>3</sup>	+8.4 cm <sup>3</sup>
Comp. Height (mm)	22.9	25	24.5

extra parts			
Top End Gasket Kit	-	-	-
Wössner Connecting rods	-	-	-
Needle bearing	-	-	-
Main bearing	-	-	2 x MB83C072C

## Yamaha® - 4 stroke



Verdichtungen beziehen sich auf Standardmaße „-DA“

Compression ratio refer to standard sizes “-DA”

Model	YZ400F / WR400F Pro Series	YZ426F / WR426F	YZ426F / WR426F Pro Series
Years	98-99	00-02 / 00-02	00-02
Displ. (cc)	399	426	426

Piston Kit Part No.	Piston size (mm)	Over size (mm)	Ring Set Part No.	Piston Kit Part No.	Piston size (mm)	Over size (mm)	Ring Set Part No.	Piston Kit Part No.	Piston size (mm)	Over size (mm)	Ring Set Part No.
8639DA	91,95	Std.	920XSY	8525DA	94,96	Std.	950XDS	8640DA	94,96	Std.	950ADS-2
8639DB	91,96	+0,01	920XSY	8525DB	94,97	+0,01	950XDS	8640DB	94,97	+0,01	950ADS-2
8639DC	91,97	+0,02	920XSY	8525DC	94,98	+0,02	950XDS	8640DC	94,98	+0,02	950ADS-2
				8525D200	96,96	+2,00	970XDS	8640D200	96,96	+2,00	970ADS-2
				8525D300	97,96	+3,00	980ADS-2				

	set includes		
Clip Part No.	CW18	CW19	CW19
Pin Part No.	WP053	WP037	WP037
Rings	included	included	included
Price-Code	7	7	7
Stroke	60.1	60.1	60.1
Wössner/ OEM Comp. ratio	13.5:1 12.5:1	12.5:1	- 12.5:1
Dome Volume (CC)	-4.6 cm <sup>3</sup>	-7 cm <sup>3</sup>	-5.75 cm <sup>3</sup>
Comp. Height (mm)	24.1	24.1	24.1

	extra parts		
Top End Gasket Kit	-	-	-
Wössner Connecting rods	-	-	-
Needle bearing	-	-	-
Main bearing	2 x MB83C072C	2 x MB83C072C	2 x MB83C072C



## Yamaha® - 4 stroke



Verdichtungen beziehen sich auf Standardmaße „-DA“

Compression ratio refer to standard sizes “-DA”

Model	YZ450F / WR450F	YZ450F / WR450F Pro Series	YZ450F / WR450F
Years	03-04	03-04	05
Displ. (cc)	449	449	449

Piston Kit Part No.	Piston size (mm)	Over size (mm)	Ring Set Part No.	Piston Kit Part No.	Piston size (mm)	Over size (mm)	Ring Set Part No.	Piston Kit Part No.	Piston size (mm)	Over size (mm)	Ring Set Part No.
8562DA	94,96	Std.	950ADS-2	8570DA	94,96	Std.	950ADS-2	8613DA	94,95	Std.	950ADS-2
8562DB	94,97	+0,01	950ADS-2	8570DB	94,97	+0,01	950ADS-2	8613DB	94,96	+0,01	950ADS-2
8562DC	94,98	+0,02	950ADS-2	8570DC	94,98	+0,02	950ADS-2	8613DC	94,97	+0,02	950ADS-2
8562D200	96,96	+2,00	970ADS-2								
8562D300	97,96	+3,00	980ADS-2								

	set includes		
Clip Part No.	CW18	CW18	CW18
Pin Part No.	WP053	WP053	WP053
Rings	included	included	included
Price-Code	7	7	7
Stroke	63.4	63.4	63.4
Wössner/ OEM Comp. ratio	- 12.5:1	- 12.5:1	12.3:1 12.3:1
Dome Volume (CC)	-9.85 cm <sup>3</sup>	-7.8 cm <sup>3</sup>	-10.3 cm <sup>3</sup>
Comp. Height (mm)	23.50	23.50	23.5

	extra parts		
Top End Gasket Kit	D4030-EST `03-05	D4030-EST `03-05	D4030-EST `03-05
Wössner Connecting rods	P4007	P4007	P4007
Needle bearing	-	-	-
Main bearing	2 x MB83C072C	2 x MB83C072C	2 x MB83C072C

## Yamaha® - 4 stroke



Verdichtungen beziehen sich auf Standardmaße „-DA“  
 Compression ratio refer to standard sizes “-DA”

Model	YZ450F / WR450F Pro Series	YZ450F / WR450F	YZ450F / WR450F Pro Series
Years	05	06-09	06-09
Displ. (cc)	449	449	449

Piston Kit Part No.	Piston size (mm)	Over size (mm)	Ring Set Part No.	Piston Kit Part No.	Piston size (mm)	Over size (mm)	Ring Set Part No.	Piston Kit Part No.	Piston size (mm)	Over size (mm)	Ring Set Part No.
8647DA	94,95	Std.	950ADS-2	8630DA	94,96	Std.	950ADS-2	8631DA	94,96	Std.	950ADS-2
8647DB	94,96	+0,01	950ADS-2	8630DB	94,97	+0,01	950ADS-2	8631DB	94,97	+0,01	950ADS-2
8647DC	94,97	+0,02	950ADS-2	8630DC	94,98	+0,02	950ADS-2	8631DC	94,98	+0,02	950ADS-2

	set includes		
Clip Part No.	CW18	CW18	CW18
Pin Part No.	WP053	WP053	WP053
Rings	included	included	included
Price-Code	7	7	7
Stroke	63.4	63.4	63.4
Wössner/ OEM Comp. ratio	13.5:1 12.3:1	12.3:1 12.3:1	13.5:1 12.3:1
Dome Volume (CC)	-6.3 cm <sup>3</sup>	-9.7 cm <sup>3</sup>	-6.1 cm <sup>3</sup>
Comp. Height (mm)	23.5	23.5	23.5

	extra parts		
Top End Gasket Kit	D4030-EST `03-05	D4031-EST	D4031-EST
Wössner Connecting rods	P4007	P4008	P4008
Needle bearing	-	-	-
Main bearing	2 x MB83C072C	2 x MB83C072C	2 x MB83C072C

## Yamaha® - 4 stroke

Verdichtungen beziehen sich auf Standardmaße „-DA“  
 Compression ratio refer to standard sizes “-DA”



Model	YZ450F Fuel injection	YZ450F Pro Series Fuel injection	YZ450F
Years	10-13	10-13	14
Displ. (cc)	449,7	449,7	449,7

Piston Kit Part No.	Piston size (mm)	Over size (mm)	Ring Set Part No.	Piston Kit Part No.	Piston size (mm)	Over size (mm)	Ring Set Part No.	Piston Kit Part No.	Piston size (mm)	Over size (mm)	Ring Set Part No.
8776DA	96,96	Std.	970ADS-2	8783DA	96,96	Std.	970ADS-2	8895DA	96,96	Std.	970ADS-2
8776DB	96,97	+0,01	970ADS-2	8783DB	96,97	+0,01	970ADS-2	8895DB	96,97	+0,01	970ADS-2
8776DC	96,98	+0,02	970ADS-2	8783DC	96,98	+0,02	970ADS-2	8895DC	96,98	+0,02	970ADS-2

set includes			
Clip Part No.	CW18	CW18	CW18
Pin Part No.	WP072	WP072	WP072
Rings	included	included	included
Price-Code	7	7	7
Stroke	60.8	60.8	60.8
Wössner/ OEM Comp. ratio	12.5:1 12.5:1	13.5:1 12.5:1	12.5:1 12.5:1
Dome Volume (CC)	-5.4 cm <sup>3</sup>	-2.1 cm <sup>3</sup>	-4,9 cm <sup>3</sup>
Comp. Height (mm)	24	24	24

extra parts			
Top End Gasket Kit	D4045-EST	D4045-EST	-
Wössner Connecting rods	P4032 `10-14	P4032 `10-14	P4032 `10-14
Needle bearing	-	-	-
Main bearing	2 x MB83C072C	2 x MB83C072C	-

## Yamaha® - 4 stroke



Verdichtungen beziehen sich auf Standardmaße „-DA“

Compression ratio refer to standard sizes “-DA”

**New!**

Model	YZ450F Pro Series	XT500 / TT500 / SR500 European models	XT600 / XT600E / TT600 / TT600R
Years	14	76-89	84-04 / 84-04 / 84-04 / 84-04
Displ. (cc)	449,7	449	595

Piston Kit Part No.	Piston size (mm)	Over size (mm)	Ring Set Part No.	Piston Kit Part No.	Piston size (mm)	Over size (mm)	Ring Set Part No.	Piston Kit Part No.	Piston size (mm)	Over size (mm)	Ring Set Part No.
8896DA	96,96	Std.	970ADS-2	8505DA	86,93	Std.	870XSY	8501DA	94,93	Std.	950XSY
8896DB	96,97	+0,01	970ADS-2	8505D050	87,43	+0,50	875XSY	8501DB	94,94	+0,01	950XSY
8896DC	96,98	+0,02	970ADS-2	8505D100	87,93	+1,00	880XSY	8501DC	94,95	+0,02	950XSY
				8505D150	88,43	+1,50	885XSY	8501D050	95,43	+0,50	955XSY
				8505D200	88,93	+2,00	890XSY	8501D100	95,93	+1,00	960XSY
				8505D300	89,93	+3,00	900XSY	8501D150	96,43	+1,50	965XSY
								8501D200	96,93	+2,00	970XSY
								8501D250	97,43	+2,50	975XSY
								8501D300	97,93	+3,00	980XSY
								8501D500	99,93	+5,00	1000XSY
								8501D600	100,93	+6,00	1010XSY
								8501D700	101,93	+7,00	1020XSU

	set includes		
Clip Part No.	CW18	CW20	CW22
Pin Part No.	WP072	WP052	WP009
Rings	included	included	included
Price-Code	7	7/1	7
Stroke	60.8	84	84
Wössner/ OEM Comp. ratio	13.5:1 12.5:1	9.8:1 9:1	- 8.5:1
Dome Volume (CC)	-2,1 cm <sup>3</sup>	+13.7 cm <sup>3</sup>	-0,5 cm <sup>3</sup>
Comp. Height (mm)	24	29	28

	extra parts		
Top End Gasket Kit	-	D4049-EST '76-83	D4047-EST / D4048-EST
Wössner Connecting rods	P4032 '10-14	-	-
Needle bearing	-	-	-
Main bearing	-	-	-

## Yamaha® - 4 stroke



Verdichtungen beziehen sich auf Standardmaße „-DA“

Compression ratio refer to standard sizes “-DA”

Model	XTZ660 Tenere	XT660R	YFM250 Timberwolf / YFB250 Bear Tracker / Bruin / Big Bear
Years	91-98	04-14	90-00 / 00-04 / 05-06 / 07-09
Displ. (cc)	660	660	229,6

Piston Kit Part No.	Piston size (mm)	Over size (mm)	Ring Set Part No.	Piston Kit Part No.	Piston size (mm)	Over size (mm)	Ring Set Part No.	Piston Kit Part No.	Piston size (mm)	Over size (mm)	Ring Set Part No.
8507DA	99,93	Std.	1000XSY	8617DA	99,95	Std.	1000XSY	8659DA	70,94	Std.	710XDS
8507DB	99,94	+0,01	1000XSY	8617DB	99,96	+0,01	1000XSY	8659D050	71,44	+0,50	715XDS
8507DC	99,95	+0,02	1000XSY	8617DC	99,97	+0,02	1000XSY	8659D100	71,94	+1,00	720XDS
8507D050	100,43	+0,50	1005XSY					8659D150	72,44	+1,50	725XDS
8507D100	100,93	+1,00	1010XSY					8659D200	72,94	+2,00	730XDS
8507D150	101,43	+1,50	1015XSY								
8507D200	101,93	+2,00	1020XSK								

	set includes		
Clip Part No.	CW22	CW23	CW16
Pin Part No.	WP017	WP024	WP041
Rings	included	included	included
Price-Code	7/1	7/1	5/1
Stroke	84	84	58
Wössner/ OEM Comp. ratio	- 9.2:1	10.7:1 10:1	- 9.5:1
Dome Volume (CC)	-0.3 cm <sup>3</sup>	-0.3 cm <sup>3</sup>	-4.7 cm <sup>3</sup>
Comp. Height (mm)	27	27.5	23.8

	extra parts		
Top End Gasket Kit	D4053-EST / D4054-EST	-	-
Wössner Connecting rods	-	-	-
Needle bearing	-	-	-
Main bearing	-	-	-

## GasGas® - 2 stroke



<b>Model</b>	EC300
<b>Years</b>	00-14
<b>Displ. (cc)</b>	297

Piston Kit Part No.	Piston size (mm)	Over size (mm)	Ring Set Part No.
8077DA	71,93	Std.	RDB7200
8077DB	71,94	0,01	RDB7200
8077DC	71,95	0,02	RDB7200

set includes	
<b>Clip Part No.</b>	CW18
<b>Pin Part No.</b>	WP033
<b>Rings</b>	included
<b>Price-Code</b>	6
<b>Stroke</b>	72
<b>Comp. Height (mm)</b>	38

extra parts	
<b>Top End Gasket Kit</b>	D2053-EST
<b>Wössner Connecting rods</b>	P2021
<b>Needle bearing</b>	N1021
<b>Main bearing</b>	-



## GasGas® - 4 stroke



Verdichtungen beziehen sich auf Standardmaße „-DA“  
 Compression ratio refer to standard sizes “-DA”

<b>Model</b>	HP450 / EC450 / FSE450	HP450 / EC450 / FES450	HP450 / EC450 / FES450
<b>Years</b>	03-04	05	06-12
<b>Displ. (cc)</b>	443	443	449

Piston Kit Part No.	Piston size (mm)	Over size (mm)	Ring Set Part No.	Piston Kit Part No.	Piston size (mm)	Over size (mm)	Ring Set Part No.	Piston Kit Part No.	Piston size (mm)	Over size (mm)	Ring Set Part No.
8585DA	94,95	Std.	950XSY	8615DA	94,95	Std.	950ADS-2	8638DA	96,95	Std.	970ADS-2
8585DB	94,96	+0,01	950XSY	8615DB	94,96	+0,01	950ADS-2	8638DB	96,96	+0,01	970ADS-2
8585DC	94,97	+0,02	950XSY	8615DC	94,97	+0,02	950ADS-2	8638DC	96,97	+0,02	970ADS-2

set includes			
<b>Clip Part No.</b>	CW20	CW20	CW20
<b>Pin Part No.</b>	WP038	WP038	WP038
<b>Rings</b>	included	included	included
<b>Price-Code</b>	7/1	7/1	7
<b>Stroke</b>	62.6	62.6	63.4
<b>Wössner/ OEM Comp. ratio</b>	-	-	-
<b>Dome Volume (CC)</b>	-6.4 cm <sup>3</sup>	-6,4 cm <sup>3</sup>	-2,8 cm <sup>3</sup>
<b>Comp. Height (mm)</b>	25.50	25.50	25.50

extra parts			
<b>Top End Gasket Kit</b>	-	-	-
<b>Wössner Connecting rods</b>	-	-	-
<b>Needle bearing</b>	-	-	-
<b>Main bearing</b>	-	-	-

## Honda® - 2 stroke



Model	ATC250R	ATC250R / TRX250R	ATC250R / TRX250R
Years	81-84	85-86	87-90
Displ. (cc)	248	246	246

Piston Kit Part No.	Piston size (mm)	Over size (mm)	Ring Set Part No.	Piston Kit Part No.	Piston size (mm)	Over size (mm)	Ring Set Part No.	Piston Kit Part No.	Piston size (mm)	Over size (mm)	Ring Set Part No.
8154DA	69,94	Std.	RDB7000	8156DA	65,94	Std.	RDB6600	8189DA	65,94	Std.	RDB6600
8154D050	70,44	+0,50	RDB7050	8156D025	66,19	+0,25	RDB6625	8189D050	66,44	+0,50	RDB6650
8154D100	70,94	+1,00	RDB7100	8156D050	66,44	+0,50	RDB6650	8189D100	66,94	+1,00	RDB6700
8154D150	71,44	+1,50	RDB7150	8156D075	66,69	+0,75	RDB6675	8189D150	67,44	+1,50	RDB6750
8154D200	71,94	+2,00	RDB7200	8156D100	66,94	+1,00	RDB6700	8189D200	67,94	+2,00	RDB6800
				8156D125	67,19	+1,25	RDB6725				
				8156D150	67,44	+1,50	RDB6750				
				8156D200	67,94	+2,00	RDB6800				
				8156D250	68,44	+2,50	RDB6850				
				8156D300	68,94	+3,00	RDB6900				
				8156D350	69,44	+3,50	RDB6950				

	set includes		
Clip Part No.	CW18	CW18	CW18
Pin Part No.	WP033	WP033	WP033
Rings	included	included	included
Price-Code	3/1	3/1	3/1
Stroke	64.4	72	72
Comp. Height (mm)	32.50	38	33

	extra parts		
Top End Gasket Kit	-	-	-
Wössner Connecting rods	-	P2021	P2042 `87-89
Needle bearing	N1021	N1021	N1021
Main bearing	-	-	2 x MB6328C3



## Honda® - 4 stroke



Verdichtungen beziehen sich auf Standardmaße „-DA“

Compression ratio refer to standard sizes “-DA”

Model	TRX250 / TE / TM / X Recon	TRX300X / TRX300EX 4 Valve	ATC350X / TRX350
Years	02-12	09-12 / 93-08	85-89
Displ. (cc)	229	282	350

Piston Kit Part No.	Piston size (mm)	Over size (mm)	Ring Set Part No.	Piston Kit Part No.	Piston size (mm)	Over size (mm)	Ring Set Part No.	Piston Kit Part No.	Piston size (mm)	Over size (mm)	Ring Set Part No.
8870DA	68,45	Std.	685XKS	8675DA	73,94	Std.	740XDS	8598DA	80,94	Std.	810XSY
8870D050	68,95	+0,50	690XKS	8675D050	74,44	+0,50	745XDS	8598D050	81,44	+0,50	815XSY
8870D100	69,45	+1,00	695XKS	8675D100	74,94	+1,00	750XDS	8598D100	81,94	+1,00	820XSY
				8675D150	75,44	+1,50	755XDS				
				8675D200	75,94	+2,00	760XDS				

	set includes		
Clip Part No.	CW15	CW17	CW21
Pin Part No.	WP102	WP090	WP034
Rings	included	included	included
Price-Code	5	7/1	7/1
Stroke	62.2	65.5	68
Wössner/ OEM Comp. ratio	10:1 10:1	12:1 12:1	10.25 10.25
Dome Volume (CC)	+4.1 cm <sup>3</sup>	+6.3 cm <sup>3</sup>	+0.6 cm <sup>3</sup>
Comp. Height (mm)	21.7	23	26.70

	extra parts		
Top End Gasket Kit	-	-	-
Wössner Connecting rods	-	-	-
Needle bearing	-	-	-
Main bearing	-	-	-

## Honda® - 4 stroke



Verdichtungen beziehen sich auf Standardmaße „-DA“  
 Compression ratio refer to standard sizes “-DA”

Model	TRX350 / ES-E Rancher 4x4 / 4x2	TRX400EX / TRX400X	TRX400EX / TRX400X
Years	00-06	99-08 / 09-12	99-08 / 09-12
Displ. (cc)	329	397	397

Piston Kit Part No.	Piston size (mm)	Over size (mm)	Ring Set Part No.	Piston Kit Part No.	Piston size (mm)	Over size (mm)	Ring Set Part No.	Piston Kit Part No.	Piston size (mm)	Over size (mm)	Ring Set Part No.
8871DA	78,45	Std.	785XDS	8702DA	84,94	Std.	850XSY	8604DA	84,94	Std.	850XSY
8871D050	78,95	+0,50	790XDS	8702D050	85,44	+0,50	855XSY	8604D050	85,44	+0,50	855XSY
8871D075	79,20	+0,75	792XDS	8702D100	85,94	+1,00	860XSY	8604D100	85,94	+1,00	860XSY
8871D100	79,45	+1,00	795XDS	8702D150	86,44	+1,50	865XSY	8604D150	86,44	+1,50	865XSY
				8702D200	86,94	+2,00	870XSY	8604D200	86,94	+2,00	870XSY
				8702D300	87,94	+3,00	880XSY	8604D300	87,94	+3,00	880XSY
				8702D400	88,94	+4,00	890XSY	8604D400	88,94	+4,00	890XSY

	set includes		
Clip Part No.	CW17	CW20	CW20
Pin Part No.	WP090	WP052	WP052
Rings	included	included	included
Price-Code	7/1	7/1	7/1
Stroke	68	70	70
Wössner/ OEM Comp. ratio	8.8:1 8.8:1	12.5:1 10:1	11:1 10:1
Dome Volume (CC)	+1.5 cm <sup>3</sup>	+8.4 cm <sup>3</sup>	+3.2 cm <sup>3</sup>
Comp. Height (mm)	24.3	26.20	26.20

	extra parts		
Top End Gasket Kit	-	-	-
Wössner Connecting rods	-	P4021	P4021
Needle bearing	-	-	-
Main bearing	-	-	-

## Honda® - 4 stroke



Verdichtungen beziehen sich auf Standardmaße „-DA“

Compression ratio refer to standard sizes “-DA”

Model	TRX400 4x4	TRX420FE	TRX450R
Years	95-03	07-11	04-05
Displ. (cc)	394	420,2	450

Piston Kit Part No.	Piston size (mm)	Over size (mm)	Ring Set Part No.	Piston Kit Part No.	Piston size (mm)	Over size (mm)	Ring Set Part No.	Piston Kit Part No.	Piston size (mm)	Over size (mm)	Ring Set Part No.
8599D050	86,43	+0,50	865XSY	8869DA	86,45	Std.	865XSY	8609DA	93,95	Std.	940XSY
8599D100	86,93	+1,00	870XSY	8869D050	86,95	+0,50	870XSY	8609DB	93,96	+0,01	940XSY
				8869D100	87,45	+1,00	875XSY	8609DC	93,97	+0,02	940XSY
				8869D150	87,95	+1,50	880XSY				
				8869D200	88,95	+2,00	885XSY				

	set includes		
Clip Part No.	CW19	CW19	CW21
Pin Part No.	WP050	WP026	WP051
Rings	included	included	included
Price-Code	7/1	7	7/1
Stroke	68	71.5	64.8
Wössner/ OEM Comp. ratio	-	9.9:1 9.8:1	10.5:1 10.5:1
Dome Volume (CC)	+0 cm <sup>3</sup>	-0.2 cm <sup>3</sup>	-0.7 cm <sup>3</sup>
Comp. Height (mm)	25	24	26

	extra parts		
Top End Gasket Kit	-	D4009-EST	D4009-EST
Wössner Connecting rods	-	P4022	P4022
Needle bearing	-	-	-
Main bearing	-	-	-

## Honda® - 4 stroke



Verdichtungen beziehen sich auf Standardmaße „-DA“  
 Compression ratio refer to standard sizes “-DA”

Model	TRX450R	TRX450R Pro Series 2. Ring	TRX450R Big Bore
Years	04-05	04-05	04-05
Displ. (cc)	450	450	469

Piston Kit Part No.	Piston size (mm)	Over size (mm)	Ring Set Part No.	Piston Kit Part No.	Piston size (mm)	Over size (mm)	Ring Set Part No.	Piston Kit Part No.	Piston size (mm)	Over size (mm)	Ring Set Part No.
8719DA	93,95	Std.	940XS	8720DA	93,95	Std.	940XS	8610DA	96,94	Std.	970XS
8719DB	93,96	+0,01	940XS	8720DB	93,96	+0,01	940XS				
8719DC	93,97	+0,02	940XS	8720DC	93,97	+0,02	940XS				

set includes			
Clip Part No.	CW21	CW21	CW21
Pin Part No.	WP051	WP051	WP051
Rings	included	included	included
Price-Code	7/1	7/1	7/1
Stroke	64.8	64.8	64.8
Wössner/ OEM Comp. ratio	11.5:1 10.5:1	13.1:1 10.5:1	10.5:1 10.5:1
Dome Volume (CC)	+3.6 cm <sup>3</sup>	+9.2 cm <sup>3</sup>	-3.3 cm <sup>3</sup>
Comp. Height (mm)	26	26	26

extra parts			
Top End Gasket Kit	D4009-EST	D4009-EST	D4010-EST
Wössner Connecting rods	P4022	P4022	P4022
Needle bearing	-	-	-
Main bearing	-	-	-

## Honda® - 4 stroke



Verdichtungen beziehen sich auf Standardmaße „-DA“  
 Compression ratio refer to standard sizes “-DA”

Model	TRX450R
Years	06-09
Displ. (cc)	450

Piston Kit Part No.	Piston size (mm)	Over size (mm)	Ring Set Part No.
8660DA	95,95	Std.	960XSY
8660DB	95,96	+0,01	960XSY
8660DC	95,97	+0,02	960XSY
8660D200	97,95	+2,00	980XSY

Clip Part No.	CW19
Pin Part No.	WP037
Rings	included
Price-Code	7/1
Stroke	62
Wössner/ OEM Comp. ratio	12:1 12:1
Dome Volume (CC)	-0.2 cm <sup>3</sup>
Comp. Height (mm)	23.8

Top End Gasket Kit	D4011-EST
Wössner Connecting rods	P4023 `06-14
Needle bearing	-
Main bearing	-



## Husaberg® - 4 stroke



Verdichtungen beziehen sich auf Standardmaße „-DA“

Compression ratio refer to standard sizes “-DA”

Model	EF400 / EFE400	EF501/ EFE501	EF600 / EFE600
Years	99-00 / 99-00	99-00 / 99-00	99-00 / 99-00
Displ. (cc)	397	500	600

Piston Kit Part No.	Piston size (mm)	Over size (mm)	Ring Set Part No.	Piston Kit Part No.	Piston size (mm)	Over size (mm)	Ring Set Part No.	Piston Kit Part No.	Piston size (mm)	Over size (mm)	Ring Set Part No.
8519DA	91,95	Std.	920XSY	8537DA	94,95	Std.	950XSY	8537DA	94,95	Std.	950XSY
8519DB	91,96	+0,01	920XSY	8537DB	94,96	+0,01	950XSY	8537DB	94,96	+0,01	950XSY
8519DC	91,97	+0,02	920XSY	8537DC	94,97	+0,02	950XSY	8537DC	94,97	+0,02	950XSY

set includes			
Clip Part No.	CW18	CW20	CW20
Pin Part No.	WP031	WP073	WP073
Rings	included	included	included
Price-Code	7/1	7/1	7/1
Stroke	60.1	70.1	70.1
Wössner/ OEM Comp. ratio	-	-	-
Dome Volume (CC)	-3.3 cm <sup>3</sup>	-2.1 cm <sup>3</sup>	-2.1 cm <sup>3</sup>
Comp. Height (mm)	22.6	23	23

extra parts			
Top End Gasket Kit	-	-	-
Wössner Connecting rods	-	-	-
Needle bearing	-	-	-
Main bearing	-	-	-

## Kawasaki® - 2 stroke



<b>Model</b>	KFX80
<b>Years</b>	03-06
<b>Displ. (cc)</b>	82

Piston Kit Part No.	Piston size (mm)	Over size (mm)	Ring Set Part No.
8282DA	49,94	Std.	RSB5000
8282D050	50,44	+0,50	RSB5050
8282D100	50,94	+1,00	RSB5100
8282D150	51,44	+1,50	RSB5150
8282D200	51,94	+2,00	RSB5200

set includes	
<b>Clip Part No.</b>	CW12
<b>Pin Part No.</b>	WP091
<b>Rings</b>	included
<b>Price-Code</b>	1
<b>Stroke</b>	42
<b>Comp. Height (mm)</b>	27

extra parts	
<b>Top End Gasket Kit</b>	-
<b>Wössner Connecting rods</b>	-
<b>Needle bearing</b>	N1036
<b>Main bearing</b>	2 x MB6204C3

Ryan Koontz, # 440 an Suzuki RMZ 250/450  
AMA National SX/MX Series 2006/07



## Kawasaki® - 4 stroke



Verdichtungen beziehen sich auf Standardmaße „-DA“  
 Compression ratio refer to standard sizes “-DA”

Model	KSF250 Mojave	KLF300 Bayou	KFX400
Years	thru 05	86-05	03-06
Displ. (cc)	249	290	398

Piston Kit Part No.	Piston size (mm)	Over size (mm)	Ring Set Part No.	Piston Kit Part No.	Piston size (mm)	Over size (mm)	Ring Set Part No.	Piston Kit Part No.	Piston size (mm)	Over size (mm)	Ring Set Part No.
8596DA	73,94	Std.	740XDS	8597DA	75,94	Std.	760XDS	8565DA	89,94	Std.	900XSY
8596D050	74,44	+0,50	745XDS	8597D050	76,44	+0,50	765XDS	8565DB	89,95	+0,01	900XSY
8596D100	74,94	+1,00	750XDS	8597D100	76,94	+1,00	770XDS	8565DC	89,96	+0,02	900XSY
								8565D400	93,94	+4,00	940XSY

	set includes		
Clip Part No.	CW18	CW18	CW20
Pin Part No.	WP031	WP031	WP029
Rings	included	included	included
Price-Code	5/1	5/1	7/1
Stroke	58	64	62.6
Wössner/ OEM Comp. ratio	- 11:1	- 8.6:1	- 11.3:1
Dome Volume (CC)	-0.4 cm <sup>3</sup>	-0.4 cm <sup>3</sup>	DA - DC = -2 cm <sup>3</sup> D400 = -5.25 cm <sup>3</sup>
Comp. Height (mm)	26.50	26.50	25.30

	extra parts		
Top End Gasket Kit	-	-	D4023-EST
Wössner Connecting rods	-	-	P4009
Needle bearing	-	-	-
Main bearing	-	-	-



## Kawasaki® - 4 stroke



Verdichtungen beziehen sich auf Standardmaße „-DA“

Compression ratio refer to standard sizes “-DA”

Model	KFX400 Pro Series 2. Ring	KFX450R	KFX450R Pro Series 2. Ring
Years	03-06	08-14	08-14
Displ. (cc)	398	449	449

Piston Kit Part No.	Piston size (mm)	Over size (mm)	Ring Set Part No.	Piston Kit Part No.	Piston size (mm)	Over size (mm)	Ring Set Part No.	Piston Kit Part No.	Piston size (mm)	Over size (mm)	Ring Set Part No.
8567DA	89,94	Std.	900XSY	8773DA	95,96	Std.	960ADS-2	8709DA	95,96	Std.	960ADS-2
8567DB	89,95	+0,01	900XSY	8773DB	95,97	+0,01	960ADS-2	8709DB	95,97	+0,01	960ADS-2
8567DC	89,96	+0,02	900XSY					8709DC	95,98	+0,02	960ADS-2
8567D550	95,44	+5,50	955XSY								

	set includes		
Clip Part No.	CW20	CW21	CW21
Pin Part No.	WP029	WP051	WP051
Rings	included	included	included
Price-Code	7	7	7
Stroke	62.6	62.1	62.1
Wössner/ OEM Comp. ratio	13.5:1 11.3:1	- 12.5:1	14.0:1 12.5:1
Dome Volume (CC)	+0.5 cm <sup>3</sup>	-2.14 cm <sup>3</sup>	+2.1 cm <sup>3</sup>
Comp. Height (mm)	25.30	26.1	26.40

	extra parts		
Top End Gasket Kit	D4023-EST	D4017-EST	D4017-EST
Wössner Connecting rods	P4009	P4019 `08-14	P4019 `08-14
Needle bearing	-	-	-
Main bearing	-	-	-

## Kawasaki® - 4 stroke



Verdichtungen beziehen sich auf Standardmaße „-DA“  
 Compression ratio refer to standard sizes “-DA”

<b>Model</b>	Brute Force 650 / Prairie 650 Twin Cylinder	KFX700 / Prairie 700 Pro Series
<b>Years</b>	05-10 / 02-03	04-10 / 04-06
<b>Displ. (cc)</b>	633	697

Piston Kit Part No.	Piston size (mm)	Over size (mm)	Ring Set Part No.	Piston Kit Part No.	Piston size (mm)	Over size (mm)	Ring Set Part No.
K8863DA-2	79,94	Std.	800XDS	8679DA	81,93	Std.	820XSY
K8863D050-2	80,44	+0,50	805XDS	8679D050	82,43	+0,50	825XSY
K8863D100-2	80,94	+1,00	810XSY	8679D100	82,93	+1,00	830XSY
K8863D150-2	81,44	+1,50	815XSY	8679D200	83,93	+2,00	840XSY
K8863D200-2	81,94	+2,00	820XSY	8679D300	84,93	+3,00	850XSY

set includes		
<b>Clip Part No.</b>	CW20	CW20
<b>Pin Part No.</b>	WP052	WP038
<b>Rings</b>	included	included
<b>Price-Code</b>	9	7
<b>Stroke</b>	63	66
<b>Wössner/ OEM Comp. ratio</b>	11:1 9.9:1	11.3:1 -11.7:1 9.9:1
<b>Dome Volume (CC)</b>	-0.4 cm <sup>3</sup>	+3.2 cm <sup>3</sup>
<b>Comp. Height (mm)</b>	26	26.30

extra parts		
<b>Top End Gasket Kit</b>	-	-
<b>Wössner Connecting rods</b>	-	-
<b>Needle bearing</b>	-	-
<b>Main bearing</b>	-	-

## Polaris® - 2 stroke



Model	Trail Boss / Scrambler / Trail Blazer250	ATV300	Trail Boss350
Years	85-05	94-00	all
Displ. (cc)	-	-	-

Piston Kit Part No.	Piston size (mm)	Over size (mm)	Ring Set Part No.	Piston Kit Part No.	Piston size (mm)	Over size (mm)	Ring Set Part No.	Piston Kit Part No.	Piston size (mm)	Over size (mm)	Ring Set Part No.
8094DA	71,93	Std.	RDB7200	8095DA	74,43	Std.	RDB7450	8096DA	79,93	Std.	RDC8000
8094DB	71,94	+0,01	RDB7200	8095DB	74,44	+0,01	RDB7450	8096DB	79,94	+0,01	RDC8000
8094D050	72,43	+0,50	RDB7250	8095D050	74,93	+0,50	RDC7500	8096D050	80,43	+0,50	RDC8050
8094D100	72,93	+1,00	RDB7300	8095D100	75,43	+1,00	RDC7550	8096D100	80,93	+1,00	RDC8100
8094D150	73,43	+1,50	RDB7350	8095D150	75,93	+1,50	RDC7600	8096D150	81,43	+1,50	RDC8150
8094D200	73,93	+2,00	RDB7400	8095D200	76,43	+2,00	RDC7650	8096D200	81,93	+2,00	RDC8200

set includes			
Clip Part No.	CW18	CW18	CW18
Pin Part No.	WP033	WP033	WP039
Rings	included	included	included
Price-Code	3/1	6	6
Stroke	60	65	70
Comp. Height (mm)	38	33	38

extra parts			
Top End Gasket Kit	-	-	-
Wössner Connecting rods	-	-	-
Needle bearing	N1022	N1022	N1024
Main bearing	-	-	-

## Polaris® - 2 stroke



Model	ATV400
Years	thru 03
Displ. (cc)	-

Piston Kit Part No.	Piston size (mm)	Over size (mm)	Ring Set Part No.
8097DA	82,93	Std.	RDC8300
8097D050	83,43	+0,50	RDC8350
8097D100	83,93	+1,00	RDC8400
8097D150	84,43	+1,50	RDC8450
8097D200	84,93	+2,00	RDC8500

set includes	
Clip Part No.	CW18
Pin Part No.	WP039
Rings	included
Price-Code	6
Stroke	70
Comp. Height (mm)	38

extra parts	
Top End Gasket Kit	-
Wössner Connecting rods	-
Needle bearing	N1024
Main bearing	-



## Polaris® - 4 stroke



Verdichtungen beziehen sich auf Standardmaße „-DA“  
 Compression ratio refer to standard sizes “-DA”

Model	Outlaw 450 MXR	500 Xplorer / ATP 500 H.O / Sportsman	Predator Pro Series
Years	08-11	96-05	03-07
Displ. (cc)	449	-	-

Piston Kit Part No.	Piston size (mm)	Over size (mm)	Ring Set Part No.	Piston Kit Part No.	Piston size (mm)	Over size (mm)	Ring Set Part No.	Piston Kit Part No.	Piston size (mm)	Over size (mm)	Ring Set Part No.
8581DA	88,96	Std.	890XSY	8691DA	91,95	Std.	920XSY	8692DA	99,14	Std.	992XSY
8581DB	88,97	+0,01	890XSY	8691D050	92,45	+0,50	925XSY				
8581DC	88,98	+0,02	890XSY	8691D100	92,95	+1,00	930XSY				

	set includes		
Clip Part No.	CW20	CW23	CW23
Pin Part No.	WP038	WP024	WP008
Rings	included	included	included
Price-Code	7	7	7
Stroke	72	75	64.6
Wössner/ OEM Comp. ratio	11:1 11:1	10.2:1 10.2:1	12.5:1 10.8:1
Dome Volume (CC)	+7.1 cm <sup>3</sup>	-9.2 cm <sup>3</sup>	+5.2 cm <sup>3</sup>
Comp. Height (mm)	23.50	33.30	28.80

	extra parts		
Top End Gasket Kit	-	-	-
Wössner Connecting rods	P4015	-	-
Needle bearing	-	-	-
Main bearing	-	-	-

## Polaris® - 4 stroke



Verdichtungen beziehen sich auf Standardmaße „-DA“  
 Compression ratio refer to standard sizes “-DA”

<b>Model</b>	Outlaw 500-HC
<b>Years</b>	06-09
<b>Displ. (cc)</b>	499

Piston Kit Part No.	Piston size (mm)	Over size (mm)	Ring Set Part No.
8692DA	99,14	Std.	992XSY

set includes	
<b>Clip Part No.</b>	CW23
<b>Pin Part No.</b>	WP008
<b>Rings</b>	included
<b>Price-Code</b>	7
<b>Stroke</b>	64.6
<b>Wössner/ OEM Comp. ratio</b>	12.5:1 11:1
<b>Dome Volume (CC)</b>	+5.2 cm <sup>3</sup>
<b>Comp. Height (mm)</b>	28.80

extra parts	
<b>Top End Gasket Kit</b>	-
<b>Wössner Connecting rods</b>	-
<b>Needle bearing</b>	-
<b>Main bearing</b>	-



## Suzuki® - 2 stroke



Model	LT80	LT250RF / LT250RG Must use stock thrust washers	LT250 Must use stock thrust washers
Years	all	85-86	87
Displ. (cc)	82	249	-

Piston Kit Part No.	Piston size (mm)	Over size (mm)	Ring Set Part No.	Piston Kit Part No.	Piston size (mm)	Over size (mm)	Ring Set Part No.	Piston Kit Part No.	Piston size (mm)	Over size (mm)	Ring Set Part No.
8282DA	49,94	Std.	RSB5000	8257DA	69,94	Std.	RDB7000	8258DA	66,94	Std.	RDB6700
8282D050	50,44	+0,50	RSB5050	8257D050	70,44	+0,50	RDB7050	8258D050	67,44	+0,50	RDB6750
8282D100	50,94	+1,00	RSB5100	8257D100	70,94	+1,00	RDB7100	8258D100	67,94	+1,00	RDB6800
8282D150	51,44	+1,50	RSB5150	8257D150	71,44	+1,50	RDB7150	8258D150	68,44	+1,50	RDB6850
8282D200	51,94	+2,00	RSB5200	8257D200	71,94	+2,00	RDB7200	8258D200	68,94	+2,00	RDB6900

	set includes		
Clip Part No.	CW12	CW18	CW18
Pin Part No.	WP091	WP033	WP033
Rings	included	included	included
Price-Code	1	3/1	3
Stroke	42	64.8	70
Comp. Height (mm)	27	33	37.2

	extra parts		
Top End Gasket Kit	-	-	-
Wössner Connecting rods	-	-	-
Needle bearing	N1036	N1024	N1024
Main bearing	-	-	-

## Suzuki® - 2 stroke



<b>Model</b>	<b>LT250</b> Must use stock thrust washers	<b>LT500R</b>
<b>Years</b>	88-92	87-90
<b>Displ. (cc)</b>	-	-

Piston Kit Part No.	Piston size (mm)	Over size (mm)	Ring Set Part No.	Piston Kit Part No.	Piston size (mm)	Over size (mm)	Ring Set Part No.
8259DA	66,94	Std.	RDB6700	8260DA	85,91	Std.	RDC8600
8259D050	67,44	+0,50	RDB6750	8260D050	86,41	+0,50	RDC8650
8259D100	67,94	+1,00	RDB6800	8260D100	86,91	+1,00	RDC8700
8259D150	68,44	+1,50	RDB6850	8260D150	87,41	+1,50	RDC8750
8259D200	68,94	+2,00	RDB6900	8260D200	87,91	+2,00	RDC8800
				8260D250	88,41	+2,50	RDC8850
				8260D300	88,91	+3,00	RDC8900
				8260D350	89,41	+3,50	RDC8950

set includes		
<b>Clip Part No.</b>	CW18	CW18
<b>Pin Part No.</b>	WP033	WP042
<b>Rings</b>	included	included
<b>Price-Code</b>	3	6
<b>Stroke</b>	70	86
<b>Comp. Height (mm)</b>	37.2	45

extra parts		
<b>Top End Gasket Kit</b>	-	-
<b>Wössner Connecting rods</b>	-	-
<b>Needle bearing</b>	N1024	N1024
<b>Main bearing</b>	1 x MB6232C3 Left 1 x MB6206C3 Right	-



## Suzuki® - 4 stroke



Verdichtungen beziehen sich auf Standardmaße „-DA“  
 Compression ratio refer to standard sizes “-DA”

Model	LT-Z400	LT-Z400 Pro Series 2. Ring	LTR450
Years	02-12	02-12	02-11
Displ. (cc)	398 / 439 / 450	398	450

Piston Kit Part No.	Piston size (mm)	Over size (mm)	Ring Set Part No.	Piston Kit Part No.	Piston size (mm)	Over size (mm)	Ring Set Part No.	Piston Kit Part No.	Piston size (mm)	Over size (mm)	Ring Set Part No.
8563DA	89,94	Std.	900XSY	8567DA	89,94	Std.	900XSY	8667DA	95,45	Std.	955XSY
8563DB	89,95	+0,01	900XSY	8567DB	89,95	+0,01	900XSY	8667DB	95,46	+0,01	955XSY
8563DC	89,96	+0,02	900XSY	8567DC	89,96	+0,02	900XSY	8667DC	95,47	+0,02	955XSY
8563D400	93,94	+4,00	940XSY	8567D550	95,44	+5,50	955XSY	8667D250	97,95	+2,50	980XSY
8563D550	95,44	+5,50	955XSY					8667D450	99,95	+4,50	1000XSY

	set includes		
Clip Part No.	CW20	CW20	CW19
Pin Part No.	WP038	WP029	WP037
Rings	included	included	included
Price-Code	7	7	7
Stroke	62.6	62.6	62.8
Wössner/ OEM Comp. ratio	- 12.2:1	- 12.2:1	11.7:1 11.7:1
Dome Volume (CC)	DA - DC = -2 cm <sup>3</sup> D450 - D500 = -5.25 cm <sup>3</sup>	+0.5 cm <sup>3</sup>	-3.0 cm <sup>3</sup>
Comp. Height (mm)	25.3	25.3	24.50

	extra parts		
Top End Gasket Kit	D4023-EST	D4023-EST	D4027-EST
Wössner Connecting rods	P4009	P4009	P4011 `06-09
Needle bearing	-	-	-
Main bearing	-	-	-

## Suzuki® - 4 stroke

Verdichtungen beziehen sich auf Standardmaße „-DA“  
 Compression ratio refer to standard sizes “-DA”



Model	LTR450 Pro Series
Years	02-11
Displ. (cc)	450

Piston Kit Part No.	Piston size (mm)	Over size (mm)	Ring Set Part No.
8699DA	95,45	Std.	955XSY
8699DB	95,46	+0,01	955XSY
8699DC	95,47	+0,02	955XSY
8699D450	99,95	+4,50	1000XSY

	set includes
Clip Part No.	CW19
Pin Part No.	WP037
Rings	included
Price-Code	7
Stroke	62.8
Wössner/ OEM Comp. ratio	13.3:1 11.7:1
Dome Volume (CC)	DA - DC = +2.3 cm <sup>3</sup> D450 = -1.2 cm <sup>3</sup>
Comp. Height (mm)	24.5

	extra parts
Top End Gasket Kit	D4027-EST
Wössner Connecting rods	P4011 '06-09
Needle bearing	-
Main bearing	-



## Yamaha® - 2 stroke



Model	YFS200 Blaster	YFS200 Blaster	YFZ350 Banshee
Years	88-06	88-06	Thru 06
Displ. (cc)	199	199	347

Piston Kit Part No.	Piston size (mm)	Over size (mm)	Ring Set Part No.	Piston Kit Part No.	Piston size (mm)	Over size (mm)	Ring Set Part No.	Piston Kit Part No.	Piston size (mm)	Over size (mm)	Ring Set Part No.
8101DA	65,94	Std.	RDB6600	8101D250	68,44	+2,5	RDB6850	8075DA	63,94	Std.	RDB6400
8101D025	66,19	+0,25	RDB6625	8101D300	68,94	+3,0	RDB6900	8075DB	63,95	+0,01	RDB6400
8101D050	66,44	+0,50	RDB6650	8101D400	69,94	+4,0	RDB7000	8075D025	64,19	+0,25	RDB6425
8101D075	66,69	+0,75	RDB6675	8101D600	71,94	+6,0	RDB7200	8075D050	64,44	+0,50	RDB6450
8101D100	66,94	+1,00	RDB6700					8075D075	64,69	+0,75	RDB6475
8101D150	67,44	+1,50	RDB6750					8075D100	64,94	+1,00	RDB6500
8101D200	67,94	+2,00	RDB6800					8075D125	65,19	+1,25	RDB6525
								8075D150	65,44	+1,50	RDB6550

set includes			
Clip Part No.	CW16	CW16	CW16
Pin Part No.	WP027	WP027	WP027
Rings	included	included	included
Price-Code	8	8	8
Stroke	57	57	54
Comp. Height (mm)	29.90	29.90	36

extra parts			
Top End Gasket Kit	D2055-EST D2070-EST	D2055-EST D2070-EST	D2068-EST D2069-EST
Wössner Connecting rods	P2030	P2030	P2035 `87-06
Needle bearing	N1017	N1017	N1017
Main bearing	MB83A915 `Left MB6308RI `Right	MB83A915 `Left MB6308RI `Right	3x MB83464A (Left 1x & Inner 2x) MB83406 `Right

## Yamaha® - 2 stroke



<b>Model</b>	YFZ350 Banshee	TriZ250
<b>Years</b>	Thru 06	85-89
<b>Displ. (cc)</b>	347	246

Piston Kit Part No.	Piston size (mm)	Over size (mm)	Ring Set Part No.	Piston Kit Part No.	Piston size (mm)	Over size (mm)	Ring Set Part No.
8075D200	65,94	+2,00	RDB6600	8175DA	67,94	Std.	RDB6800
8075D250	66,44	+2,50	RDB6650	8175D050	68,44	+0,50	RDB6850
8075D275	66,69	+2,75	RDB6675	8175D100	68,94	+1,00	RDB6900
8075D300	66,94	+3,00	RDB6700	8175D150	69,44	+1,50	RDB6950
8075D400	67,94	+4,00	RDB6800	8175D200	69,94	+2,00	RDB7000
8075D450	68,44	+4,50	RDB6850				

set includes		
<b>Clip Part No.</b>	CW16	CW18
<b>Pin Part No.</b>	WP027	WP033
<b>Rings</b>	included	included
<b>Price-Code</b>	8	3/1
<b>Stroke</b>	54	68
<b>Comp. Height (mm)</b>	36	35.8

extra parts		
<b>Top End Gasket Kit</b>	D2069-EST	-
<b>Wössner Connecting rods</b>	P2035 `87-06	-
<b>Needle bearing</b>	N1017	N1022
<b>Main bearing</b>	MB83464A 3x (Left 1x & Inner 2x) MB83406 `Right	-

## Yamaha® - 2 stroke



<b>Model</b>	YFZ350 Banshee / Long Rod Kit (+5mm) Must use Long Rod crank	YFZ350 Banshee / Long Rod Stroker Kit Must use Long Rod crank Stroke: 58mm
<b>Years</b>	Thru 06	Thru 06
<b>Displ. (cc)</b>	347	373

Piston Kit Part No.	Piston size (mm)	Over size (mm)	Ring Set Part No.	Piston Kit Part No.	Piston size (mm)	Over size (mm)	Ring Set Part No.
K8251DA-2	63,94	Std.	RDB6400	K8252DA-2	63,94	Std.	RDB6400
K8251D050-2	64,44	+0,50	RDB6450	K8252D050-2	64,44	+0,50	RDB6450
K8251D100-2	64,94	+1,00	RDB6500	K8252D100-2	64,94	+1,00	RDB6500
K8251D150-2	65,44	+1,50	RDB6550	K8252D150-2	65,44	+1,50	RDB6550
K8251D200-2	65,94	+2,00	RDB6600	K8252D200-2	65,94	+2,00	RDB6600

set includes		
<b>Clip Part No.</b>	CW16	CW16
<b>Pin Part No.</b>	WP027	WP027
<b>Rings</b>	included	included
<b>Price-Code</b>	8K	8K
<b>Stroke</b>	54	58
<b>Comp. Height (mm)</b>	31	31

extra parts		
<b>Top End Gasket Kit</b>	D2069-EST	D2069-EST
<b>Wössner Connecting rods</b>	P2049 `87-06	P2049 `87-06
<b>Needle bearing</b>	N1017	N1017
<b>Main bearing</b>	-	-

## Yamaha® - 4 stroke



Verdichtungen beziehen sich auf Standardmaße „-DA“  
 Compression ratio refer to standard sizes “-DA”

Model	YFM 250R Raptor / YBR250	YFM350 Warrior / Big Bear
Years	08-12	86-05
Displ. (cc)		349

Piston Kit Part No.	Piston size (mm)	Over size (mm)	Ring Set Part No.	Piston Kit Part No.	Piston size (mm)	Over size (mm)	Ring Set Part No.
8724DA	73,95	Std.	740XDS	8605DA	82,94	Std.	830XSY
8724DB	73,96	+0,01	740XDS	8605DB	82,95	+0,01	830XSY
8724D200	75,95	+2,00	760XDS	8605D050	83,44	+0,50	835XSY
				8605D100	83,94	+1,00	840XSY

set includes		
Clip Part No.	CW17	CW19
Pin Part No.	WP083	WP026
Rings	included	included
Price-Code	5/1	5/1
Stroke	58	64.5
Wössner/ OEM Comp. ratio	12:1 9.5:1	- 9.2:1
Dome Volume (CC)	DA - DB = +2.37 cm <sup>3</sup> D200 = +1.1 cm <sup>3</sup>	+2.3 cm <sup>3</sup>
Comp. Height (mm)	23.5	28.30

extra parts		
Top End Gasket Kit	D4040-EST	-
Wössner Connecting rods	-	P4036 '87-04
Needle bearing	-	-
Main bearing	-	-

## Yamaha® - 4 stroke

Verdichtungen beziehen sich auf Standardmaße „-DA“  
 Compression ratio refer to standard sizes “-DA”



Model	YFZ450	YFZ450 Pro Series	YFZ450 / YFZ450R
Years	04-05	04-05	06-12 / 09-14
Displ. (cc)	449	449	449

Piston Kit Part No.	Piston size (mm)	Over size (mm)	Ring Set Part No.	Piston Kit Part No.	Piston size (mm)	Over size (mm)	Ring Set Part No.	Piston Kit Part No.	Piston size (mm)	Over size (mm)	Ring Set Part No.
8601DA	94,95	Std.	950XSY	8655DA	94,95	Std.	950ADS-2	8784DA	94,95	Std.	950XDS
8601DB	94,96	+0,01	950XSY	8655DB	94,96	+0,01	950ADS-2	8784DB	94,96	+0,01	950XDS
8601DC	94,97	+0,02	950XSY					8784DC	94,97	+0,02	950XDS
8601D300	97,95	+3,00	980XSY								

	set includes		
Clip Part No.	CW20	CW20	CW20
Pin Part No.	WP038	WP038	WP029
Rings	included	included	included
Price-Code	7	7	7
Stroke	62	62	63.4
Wössner/ OEM Comp. ratio	- 11.9:1	12.6:1 11.9:1	11.6:1 11.4:1
Dome Volume (CC)	-7.36 cm <sup>3</sup>	-2.8 cm <sup>3</sup>	-8.5 cm <sup>3</sup>
Comp. Height (mm)	25	25	25.1

	extra parts		
Top End Gasket Kit	D4030-EST	D4030-EST	D4030-EST `04-09 D4031-EST `10-13
Wössner Connecting rods	P4029	P4029	P4030 `06-14
Needle bearing	-	-	-
Main bearing	2 x MB83C072C	2 x MB83C072C	2 x MB83C072C

## Yamaha® - 4 stroke



Verdichtungen beziehen sich auf Standardmaße „-DA“  
 Compression ratio refer to standard sizes “-DA”

Model	YFZ450 / YFZ450R Pro-Series	YFM600 Grizzly	YFM660R Raptor / YFM660F Grizzly
Years	06-12 / 09-14	98-01	01-09
Displ. (cc)	449	595	660

Piston Kit Part No.	Piston size (mm)	Over size (mm)	Ring Set Part No.	Piston Kit Part No.	Piston size (mm)	Over size (mm)	Ring Set Part No.	Piston Kit Part No.	Piston size (mm)	Over size (mm)	Ring Set Part No.
8657DA	94,95	Std.	950ADS-2	8501DA	94,93	Std.	950XSY	8507DA	99,93	Std.	1000XSY
8657DB	94,96	+0,01	950ADS-2	8501DB	94,94	+0,01	950XSY	8507DB	99,94	+0,01	1000XSY
8657DC	94,97	+0,02	950ADS-2	8501DC	94,95	+0,02	950XSY	8507DC	99,95	+0,02	1000XSY
				8501D050	95,43	+0,50	955XSY	8507D050	100,43	+0,50	1005XSY
				8501D100	95,93	+1,00	960XSY	8507D100	100,93	+1,00	1010XSY
				8501D150	96,43	+1,50	965XSY	8507D150	101,43	+1,50	1015XSY
				8501D200	96,93	+2,00	970XSY	8507D200	101,93	+2,00	1020XSK
				8501D250	97,43	+2,50	975XSY				
				8501D300	97,93	+3,00	980XSY				
				8501D500	99,93	+5,00	1000XSY				
				8501D600	100,93	+6,00	1010XSY				
				8501D700	101,93	+7,00	1020XSU				

	set includes		
Clip Part No.	CW20	CW22	CW22
Pin Part No.	WP038	WP009	WP017
Rings	included	included	included
Price-Code	7	7	7/1
Stroke	63.4	84	84
Wössner/ OEM Comp. ratio	13.5:1 11.4:1	- 8.5:1	- 9.1:1
Dome Volume (CC)	-1.6 cm <sup>3</sup>	-0.5 cm <sup>3</sup>	-0.3 cm <sup>3</sup>
Comp. Height (mm)	25.10	28	27

	extra parts		
Top End Gasket Kit	D4030-EST `04-09 D4031-EST `10-13	-	D4042-EST
Wössner Connecting rods	P4030 `06-14	-	P4037 `01 P4038 `02-05
Needle bearing	-	-	-
Main bearing	2 x MB83C072C	-	-



## Yamaha® - 4 stroke



Verdichtungen beziehen sich auf Standardmaße „-DA“  
 Compression ratio refer to standard sizes “-DA”

Model	YFM660R Raptor / YFM660F Grizzly Pro Series	YFM700 Raptor Pro Series
Years	01-09	06-14
Displ. (cc)	660	686

Piston Kit Part No.	Piston size (mm)	Over size (mm)	Ring Set Part No.	Piston Kit Part No.	Piston size (mm)	Over size (mm)	Ring Set Part No.
8577DA	99,93	Std.	1000XSY	8673DA	101,94	Std.	1020XSK
8577DB	99,94	+0,01	1000XSY	8673D100	102,94	+1,0	1030XSU
8577DC	99,95	+0,02	1000XSY	8673D200	103,94	+2,0	1040XSU
8577D200	101,93	+2,00	1020XSU				

	set includes	
Clip Part No.	CW22	CW23
Pin Part No.	WP009	WP024
Rings	included	included
Price-Code	7	7
Stroke	84	84
Wössner/ OEM Comp. ratio	- 9.2:1	11:1 9.2:1
Dome Volume (CC)	+18.2 cm <sup>3</sup>	+7.1 cm <sup>3</sup>
Comp. Height (mm)	27	27.50

	extra parts	
Top End Gasket Kit	D4042-EST	-
Wössner Connecting rods	P4037 `01 P4038 `02-05	P4031
Needle bearing	-	-
Main bearing	-	-

## Aprilia® - 2 stroke



<b>Model</b>	Futura / AF1/ RX / Red Rose / Rally/ Syntesi / Pegaso / Tuareg / Europe / Replica / RS125/	RS125 Single Ring
<b>Years</b>	85-12	-
<b>Displ. (cc)</b>	125	-

Piston Kit Part No.	Piston size (mm)	Over size (mm)	Ring Set Part No.	Piston Kit Part No.	Piston size (mm)	Over size (mm)	Ring Set Part No.
8027DA	53,95	Std.	RDB5400	8253DA	53,95	Std.	RSB5400
8027DB	53,96	+0,01	RDB5400	8253DB	53,96	+0,01	RSB5400
8027DC	53,97	+0,02	RDB5400	8253DC	53,97	+0,02	RSB5400
8027DD	53,98	+0,03	RDB5400				
8027DE	53,99	+0,04	RDB5400				
8027D025	54,20	+0,25	RDB5425				
8027D050	54,45	+0,50	RDB5450				
8027D075	54,70	+0,75	RDB5475				
8027D100	54,95	+1,00	RDB5500				

set includes		
<b>Clip Part No.</b>	CW15	CW15
<b>Pin Part No.</b>	WP032	WP032
<b>Rings</b>	included	included
<b>Price-Code</b>	2	2
<b>Stroke</b>	54.5	54.5
<b>Comp. Height (mm)</b>	29	29

extra parts		
<b>Top End Gasket Kit</b>	D2091-EST `95-09	D2091-EST `95-09
<b>Wössner Connecting rods</b>	P2051	P2051
<b>Needle bearing</b>	N1010	N1010
<b>Main bearing</b>	-	-

## Aprilia® - 2 stroke



<b>Model</b>	GP 125	RS250 / Bicilindrico Twin Single Ring
<b>Years</b>	-	all
<b>Displ. (cc)</b>	125	249

Piston Kit Part No.	Piston size (mm)	Over size (mm)	Ring Set Part No.	Piston Kit Part No.	Piston size (mm)	Over size (mm)	Ring Set Part No.
8243DA	53,965	Std.	RSA5400	8039DA	55,95	Std.	RSB5600
8243D005	53,970	+0,005	RSA5400	8039DB	55,96	+0,01	RSB5600
8243D015	53,980	+0,015	RSA5400	8039DC	55,97	+0,02	RSB5600
				8039D050	56,45	+0,50	RSB5650
				8039D100	56,95	+1,00	RSB5700

set includes	
<b>Clip Part No.</b>	CW15 CW16
<b>Pin Part No.</b>	WP032 WP036
<b>Rings</b>	included included
<b>Price-Code</b>	21 2
<b>Stroke</b>	54.5 50.6
<b>Comp. Height (mm)</b>	24 22.20

extra parts	
<b>Top End Gasket Kit</b>	-
<b>Wössner Connecting rods</b>	-
<b>Needle bearing</b>	N1010
<b>Main bearing</b>	-

## BMW® - 4 stroke



Verdichtungen beziehen sich auf Standardmaße „-DA“

Compression ratio refer to standard sizes “-DA”

Model	1100RS / 1100GS / 1100S / 1150RS / 1150GS / 1150S	1100RS / 1100GS / 1100S / 1150RS / 1150GS / 1150S	1100RS / 1100GS / 1100RT / 1100R / 1150 RS / 1150GS / 1150RT / 1150R Longer con rod *
Years	all	all	all
Displ. (cc)	1085	1129	1170

Piston Kit Part No.	Piston size (mm)	Over size (mm)	Ring Set Part No.	Piston Kit Part No.	Piston size (mm)	Over size (mm)	Ring Set Part No.	Piston Kit Part No.	Piston size (mm)	Over size (mm)	Ring Set Part No.
K8543DA-2	98,96	Std.	990XSY	K8543D200-2	100,96	+2,00	1010XSY	K8711D200-2	100,96	Std.	1010XSY

	set includes		
Clip Part No.	C22x1,6	C22x1,6	C22x1,6
Pin Part No.	WP009	WP009	WP009
Rings	included	included	included
Price-Code	9	9	9
Stroke	70.5	70.5	70.5
Wössner/ OEM Comp. ratio	- 10.7:1	- 10.7:1	12.5:1 10.7:1
Dome Volume (CC)	+2.3 cm <sup>3</sup>	+2.3 cm <sup>3</sup>	+4.4 cm <sup>3</sup>
Comp. Height (mm)	32.10	32.10	29

	extra parts		
Top End Gasket Kit	-	-	-
Wössner Connecting rods	-	-	PM001-2
Needle bearing	-	-	-
Main bearing	-	-	-

## BMW® - 4 stroke



Verdichtungen beziehen sich auf Standardmaße „-DA“

Compression ratio refer to standard sizes “-DA”

Model	1200ST / 1200C Cruiser Welle	R1200GS / R1200S / R1200ST / R1200RT / R1200R	R1200GS / R1200S / R1200ST / R1200RT / R1200R - Pro-Series
Years	all	06-09	06-09
Displ. (cc)	1170	1170	1170

Piston Kit Part No.	Piston size (mm)	Over size (mm)	Ring Set Part No.	Piston Kit Part No.	Piston size (mm)	Over size (mm)	Ring Set Part No.	Piston Kit Part No.	Piston size (mm)	Over size (mm)	Ring Set Part No.
K8544DA-2	100,96	Std.	1010XSY-3	K8658DA-2	100,96	Std.	1010XSY	K8695DA-2	100,96	Std.	1010XSY

set includes			
Clip Part No.	C22x1,6	C22x1,6	C22x1,6
Pin Part No.	WP009	WP009	WP009
Rings	included	included	included
Price-Code	9	9	9
Stroke	73	73	73
Wössner/ OEM Comp. ratio	- 10:1	- 12:1	12.7:1 12:1
Dome Volume (CC)	+2.4 cm <sup>3</sup>	-3.4 cm <sup>3</sup>	+ 4.4 cm <sup>3</sup>
Comp. Height (mm)	30.70	30.9	30.9

extra parts			
Top End Gasket Kit	-	-	-
Wössner Connecting rods	-	-	-
Needle bearing	-	-	-
Main bearing	-	-	-

## BMW® - 4 stroke



Verdichtungen beziehen sich auf Standardmaße „-DA“  
 Compression ratio refer to standard sizes “-DA”

Model	R1200GS / R1200S / R1200ST / R1200RT / R1200R Pro Series - Longer con rod *	R1200GS / R1200RT / R1200R (DOHC) Radial Head	R1200GS / R1200RT / R1200R (DOHC) Longer con rod * Radial Head
Years	06-09	10-12	10-12
Displ. (cc)	1170	1170	1170

Piston Kit Part No.	Piston size (mm)	Over size (mm)	Ring Set Part No.	Piston Kit Part No.	Piston size (mm)	Over size (mm)	Ring Set Part No.	Piston Kit Part No.	Piston size (mm)	Over size (mm)	Ring Set Part No.
K8710DA-2	100,96	Std.	1010XSY	K8788DA-2	100,96	Std.	1010XSY	K8789DA-2	100,96	Std.	1010XSY
K8710D200-2	102,96	+2,0	1030XSU					K8789D350-2	104,46	+3,5	1045XSU
								K8789D400-2	104,96	+4,0	1050XSU

	set includes		
Clip Part No.	C22x1,6	OEM	C22x1,6
Pin Part No.	WP009	WP069	WP009
Rings	included	included	included
Price-Code	9	9	9
Stroke	73	73	73
Wössner/ OEM Comp. ratio	12.7:1 12:1	12.5:1 12:1	12.5:1 12:1
Dome Volume (CC)	+4.4 cm <sup>3</sup>	-2.4 cm <sup>3</sup>	-2.4 cm <sup>3</sup> / -8.9 cm <sup>3</sup>
Comp. Height (mm)	27.9	31	28

	extra parts		
Top End Gasket Kit	-	-	-
Wössner Connecting rods	KPM001	-	KPM001
Needle bearing	-	-	-
Main bearing	-	-	-

## Cagiva® - 2 stroke



Model	Mito / Raptor / Supercity / Planet / W8 / domed Head 200A,C,D,E,G	Mito/ Raptor / Supercity / Planet / W8 / Flat top Head 200H,M
Years	00-12	< 00
Displ. (cc)	124	124

Piston Kit Part No.	Piston size (mm)	Over size (mm)	Ring Set Part No.	Piston Kit Part No.	Piston size (mm)	Over size (mm)	Ring Set Part No.
8018DA	55,95	Std.	RDB5600	8053DA	55,95	Std.	RDB5600
8018DB	55,96	+0,01	RDB5600	8053DB	55,96	+0,01	RDB5600
8018DC	55,97	+0,02	RDB5600	8053DC	55,97	+0,02	RDB5600
8018D050	56,45	+0,50	RDB5650	8053D050	56,45	+0,50	RDB5650
8018D100	56,95	+1,00	RDB5700	8053D100	56,95	+1,00	RDB5700

set includes		
Clip Part No.	CW16	CW16
Pin Part No.	WP036	WP036
Rings	included	included
Price-Code	2	2
Stroke	50.6	50.6
Comp. Height (mm)	25	25

extra parts		
Top End Gasket Kit	-	-
Wössner Connecting rods	-	-
Needle bearing	N1014	N1014
Main bearing	-	-

## Ducati® - 4 stroke



Model	848 Racing	900SS / 900Monster	996SPS / 996RS / 996Monster S4R
Years	07-08	all	all
Displ. (cc)	848	904	996

Piston Kit Part No.	Piston size (mm)	Over size (mm)	Ring Set Part No.	Piston Kit Part No.	Piston size (mm)	Over size (mm)	Ring Set Part No.	Piston Kit Part No.	Piston size (mm)	Over size (mm)	Ring Set Part No.
K8765DA-2	93,94	Std.	940XSY	K8545DA-2	91,94	Std.	920XSY	K8757DA-2	97,94	Std.	980XSY
				K8545D200-2	93,94	+2,0	940XSY				
				K8545D300-2	94,94	+3,0	950XSY				
				K8545D400-2	95,94	+4,0	960XSY				

	set includes		
Clip Part No.	CW20	CW19	CW20
Pin Part No.	WP038	WP018	WP029
Rings	included	included	included
Price-Code	24	24	24
Stroke	61.2	68	66
Wössner/ OEM Comp. ratio	- 12:1	13.5:1 9.2:1	- 11.5:1
Dome Volume (CC)	-3.2 cm <sup>3</sup>	+13.3 cm <sup>3</sup>	-1.3 cm <sup>3</sup>
Comp. Height (mm)	28	28.60	27.4

	extra parts		
Top End Gasket Kit	-	-	-
Wössner Connecting rods	-	-	-
Needle bearing	-	-	-
Main bearing	-	-	-



## Ducati® - 4 stroke



Verdichtungen beziehen sich auf Standardmaße „-DA“  
 Compression ratio refer to standard sizes “-DA”

Model	998 Testa Stretta Racing / 999S	999R Racing	999R Racing
Years	all	03-04	05-06
Displ. (cc)	998	999	999

Piston Kit Part No.	Piston size (mm)	Over size (mm)	Ring Set Part No.	Piston Kit Part No.	Piston size (mm)	Over size (mm)	Ring Set Part No.	Piston Kit Part No.	Piston size (mm)	Over size (mm)	Ring Set Part No.
K8758DA-2	99,94	Std.	1000XSY	K8759DA-2	103,94	Std.	1040XSU	K8760DA-2	103,94	Std.	1040XSU

set includes			
Clip Part No.	CW20	-	-
Pin Part No.	WP038	-	-
Rings	included	included	included
Price-Code	24	24	24
Stroke	63.5	58.8	-
Wössner/ OEM Comp. ratio	- 11.4:1	- 12.5:1	- 12.5:1
Dome Volume (CC)	-5.3 cm <sup>3</sup>	-	-
Comp. Height (mm)	26.8	-	-

extra parts			
Top End Gasket Kit	-	-	-
Wössner Connecting rods	-	-	-
Needle bearing	-	-	-
Main bearing	-	-	-



## Ducati® - 4 stroke



Verdichtungen beziehen sich auf Standardmaße „-DA“

Compression ratio refer to standard sizes “-DA”

Model	999RS / 1098RS	1098R / 1098SP	1198S
Years	all	all	-
Displ. (cc)	1099	1099	1198

Piston Kit Part No.	Piston size (mm)	Over size (mm)	Ring Set Part No.	Piston Kit Part No.	Piston size (mm)	Over size (mm)	Ring Set Part No.	Piston Kit Part No.	Piston size (mm)	Over size (mm)	Ring Set Part No.
K8764DA-2	103,93	Std.	1040XSU	K8763DA-2	105,93	Std.	1060XSU	K8833D200-2	105,93	Std.	1060XSU

set includes			
Clip Part No.	CW20	CW20	CW20
Pin Part No.	WP038	WP038	WP038
Rings	included	included	included
Price-Code	24	24	24
Stroke	58.5	67.9	67.9
Wössner/ OEM Comp. ratio	- 12.5:1	12.8:1 12.8:1	- 12.8:1
Dome Volume (CC)	-0.2 cm <sup>3</sup>	-9.2 cm <sup>3</sup>	-2.6 cm <sup>3</sup>
Comp. Height (mm)	26.8	26	26.5

extra parts			
Top End Gasket Kit	-	-	-
Wössner Connecting rods	-	-	-
Needle bearing	-	-	-
Main bearing	-	-	-

## Honda® - 2 stroke



Model	RS125 GP	RS125 GP	RS125 GP Domed
Years	92-94	95-97	03-07
Displ. (cc)	124	124	124

Piston Kit Part No.	Piston size (mm)	Over size (mm)	Ring Set Part No.	Piston Kit Part No.	Piston size (mm)	Over size (mm)	Ring Set Part No.	Piston Kit Part No.	Piston size (mm)	Over size (mm)	Ring Set Part No.
8162DA	53,93	Std.	RSA5400	8242DA	53,93	Std.	RSA5400	8244DA	53,94	Std.	RSA5400
8162DB	53,94	+0,01	RSA5400	8242DB	53,94	+0,01	RSA5400	8244DB	53,95	+0,01	RSA5400
8162DC	53,95	+0,02	RSA5400					8244DC	53,96	+0,02	RSA5400
8162DD	53,96	+0,03	RSA5400								

	set includes		
Clip Part No.	CW14	CW15	CW15
Pin Part No.	WP025	WP032	WP067
Rings	included	included	included
Price-Code	21	21	21
Stroke	54.5	54.5	54.5
Comp. Height (mm)	30	29	29

	extra parts		
Top End Gasket Kit	-	-	-
Wössner Connecting rods	-	-	-
Needle bearing	N1010	-	-
Main bearing	-	-	-

## Honda® - 2 stroke



Model	RS125 GP Flat
Years	03-07
Displ. (cc)	124

Piston Kit Part No.	Piston size (mm)	Over size (mm)	Ring Set Part No.
8245DA	53,94	Std.	RSA5400
8245DB	53,95	+0,01	RSA5400

set includes	
Clip Part No.	CW15
Pin Part No.	WP067
Rings	included
Price-Code	21
Stroke	54.5
Comp. Height (mm)	29

extra parts	
Top End Gasket Kit	-
Wössner Connecting rods	-
Needle bearing	-
Main bearing	-



Herman Jolink  
Ducati 1198 RS (1266) Drag Bike

## Honda® - 4 stroke



Verdichtungen beziehen sich auf Standardmaße „-DA“

Compression ratio refer to standard sizes “-DA”

Model	CB750 F / CB750 K 2 Valve	CB750 4 Valve	RVT1000R / VTR1000 SP1 RC51 / VTR1000 SP2
Years	69-78	79-82	00-06
Displ. (cc)	836	823	999

Piston Kit Part No.	Piston size (mm)	Over size (mm)	Ring Set Part No.	Piston Kit Part No.	Piston size (mm)	Over size (mm)	Ring Set Part No.	Piston Kit Part No.	Piston size (mm)	Over size (mm)	Ring Set Part No.
K8799D400-4	64,94	+4,0	650XKS	K8834D300-4	64,94	+3,00	-	K8803DA-2	99,95	Std.	-

set includes			
Clip Part No.	CW15	-	-
Pin Part No.	WP102	-	-
Rings	included	included	included
Price-Code	10	-	9
Stroke	63	62	63,6
Wössner/ OEM Comp. ratio	10.25:1 9.2:1	10.25:1 9.2:1	- 10.8:1
Dome Volume (CC)	+5.3 cm <sup>3</sup>	-	-
Comp. Height (mm)	23.5	-	-

extra parts			
Top End Gasket Kit	C8001	-	-
Wössner Connecting rods	-	-	-
Needle bearing	-	-	-
Main bearing	-	-	-

## Honda® - 4 stroke



Verdichtungen beziehen sich auf Standardmaße „-DA“

Compression ratio refer to standard sizes “-DA”

Model	CBR954RR	CBR1000RR
Years	02-04	04-07
Displ. (cc)	954	998

Piston Kit Part No.	Piston size (mm)	Over size (mm)	Ring Set Part No.	Piston Kit Part No.	Piston size (mm)	Over size (mm)	Ring Set Part No.
K8804DA-4	74,94	Std.	-	K8742DA-4	74,95	Std.	750XKS
				K8742D200-4	76,95	+2,0	RIK77.00D3

set includes		
Clip Part No.	-	CW17
Pin Part No.	-	WP083
Rings	included	included
Price-Code	10	10/1
Stroke	54	56.5
Wössner/ OEM Comp. ratio	- 11.5:1	13.5:1 12.2:1
Dome Volume (CC)	-	+0 cm <sup>3</sup>
Comp. Height (mm)	-	23.5

extra parts		
Top End Gasket Kit	C8406	C8787
Wössner Connecting rods	-	-
Needle bearing	-	-
Main bearing	-	-

## Honda® - 4 stroke



Verdichtungen beziehen sich auf Standardmaße „-DA“  
 Compression ratio refer to standard sizes “-DA”

**New!**

Model	CBR1000RR Racing	CB1100F / CB1100R	Moto3
Years	08-11	82-84 / 82-84	-
Displ. (cc)	1025	1123	-

Piston Kit Part No.	Piston size (mm)	Over size (mm)	Ring Set Part No.	Piston Kit Part No.	Piston size (mm)	Over size (mm)	Ring Set Part No.	Piston Kit Part No.	Piston size (mm)	Over size (mm)	Ring Set Part No.
K8743DA-4	75,96	Std.	760XAS	K8561D200-4	71,94	+2,00	720XDS	8883DA	77,96	Std.	OEM
K8743D200-4	77,96	+2,00	780XAS					8883DB	77,97	+0,01	OEM

set includes			
Clip Part No.	CW17	CW17	CW16
Pin Part No.	WP083	WP083	WP112
Rings	included	included	included
Price-Code	10/1	10/1	27
Stroke	56.5	69	52.2
Wössner/ OEM Comp. ratio	13.5:1 12.3:1	- 9.7:1	-
Dome Volume (CC)	-3.3 cm <sup>3</sup>	+3.7 cm <sup>3</sup>	-2.8 cm <sup>3</sup>
Comp. Height (mm)	23.50	25.40	19.50

extra parts			
Top End Gasket Kit	-	C8006	-
Wössner Connecting rods	-	-	-
Needle bearing	-	-	-
Main bearing	-	-	-

## Kawasaki® - 2 stroke



Model	350 S2 / Mach II	400 S3	500 S / 500 H1 / 500 KH Triple Cylinder
Years	71	-	69-76
Displ. (cc)	346	400	-

Piston Kit Part No.	Piston size (mm)	Over size (mm)	Ring Set Part No.	Piston Kit Part No.	Piston size (mm)	Over size (mm)	Ring Set Part No.	Piston Kit Part No.	Piston size (mm)	Over size (mm)	Ring Set Part No.
K8255DA-3	52,94	Std.	RDB5300	K8275DA-3	56,94	Std.	RDB5700	K8247DA-3	59,93	Std.	RDB6000
K8255D050-3	53,44	+0,5	RDB5350	K8275D050-3	57,44	+0,5	RDB5750	K8247D050-3	60,43	+0,5	RDB6050
K8255D100-3	53,94	+1,0	RDB5400	K8275D100-3	57,94	+1,0	RDB5800	K8247D100-3	60,93	+1,0	RDB6100
K8255D150-3	54,44	+1,5	RDB5450	K8275D150-3	58,44	+1,5	RDB5850	K8247D150-3	61,43	+1,5	RDB6150
				K8275D200-3	58,94	+2,0	RDB5900	K8247D200-3	61,93	+2,0	RDB6200

	set includes		
Clip Part No.	CW15	CW15	CW16
Pin Part No.	WP032	WP032	WP041
Rings	included	included	included
Price-Code	29	-	29
Stroke	52.3	52.3	58.8
Comp. Height (mm)	28.5	28.5	31.9

	extra parts		
Top End Gasket Kit	-	-	-
Wössner Connecting rods	-	-	-
Needle bearing	-	-	N1014
Main bearing	-	-	-



## Kawasaki® - 2 stroke



<b>Model</b>	750 Mach IV / 750 H2 Triple Cylinder
<b>Years</b>	72-75
<b>Displ. (cc)</b>	-

Piston Kit Part No.	Piston size (mm)	Over size (mm)	Ring Set Part No.
K8248DA-3	70,93	Std.	RDB7100
K8248D050-3	71,43	+0,5	RDB7150
K8248D100-3	71,93	+1,0	RDB7200
K8248D150-3	72,43	+1,5	RDB7250
K8248D200-3	72,93	+2,0	RDB7300
K8248D250-3	73,43	+2,5	RDB7350

set includes	
<b>Clip Part No.</b>	CW16
<b>Pin Part No.</b>	WP027
<b>Rings</b>	included
<b>Price-Code</b>	30
<b>Stroke</b>	63
<b>Comp. Height (mm)</b>	32

extra parts	
<b>Top End Gasket Kit</b>	-
<b>Wössner Connecting rods</b>	-
<b>Needle bearing</b>	N1017
<b>Main bearing</b>	-



## Kawasaki® - 4 stroke



Verdichtungen beziehen sich auf Standardmaße „-DA“  
 Compression ratio refer to standard sizes “-DA”

\* OEM rings must be used

Model	EX650 Ninja 3. Ring	EX650 Ninja 2. Ring	ZX10R Racing
Years	06-12	06-13	04-07
Displ. (cc)	649	649	998 / 1051

Piston Kit Part No.	Piston size (mm)	Over size (mm)	Ring Set Part No.	Piston Kit Part No.	Piston size (mm)	Over size (mm)	Ring Set Part No.	Piston Kit Part No.	Piston size (mm)	Over size (mm)	Ring Set Part No.
K8696DA-2	82,95	Std.	OEM *	K8697DA-2	82,95	Std.	830XSY	K8746DA-4	75,94	Std.	760XWY
								K8746D200-4	77,94	+2,0	780XWY
								K8746D300-4	78,94	+3,0	RIK79.00D3

	set includes		
Clip Part No.	CW19	CW19	CW17
Pin Part No.	WP028	WP028	WP083
Rings	not included / OEM	included	included
Price-Code	9/1	9/1	10/1
Stroke	60	60	55
Wössner/ OEM Comp. ratio	12.6:1 11.3:1	12.6:1 11.3:1	13.4:1 12.7:1
Dome Volume (CC)	-3.7 cm <sup>3</sup>	-4.4 cm <sup>3</sup>	-1.8 cm <sup>3</sup>
Comp. Height (mm)	23.6	23.6	22.7

	extra parts		
Top End Gasket Kit	-	-	C8576
Wössner Connecting rods	-	-	-
Needle bearing	-	-	-
Main bearing	-	-	-

## Kawasaki® - 4 stroke



Verdichtungen beziehen sich auf Standardmaße „-DA“

Compression ratio refer to standard sizes “-DA”

Model	ZX10R Turbo	ZX10R	ZX10R Turbo
Years	04-07	08-10	08-10
Displ. (cc)	998 / 1051	998 / 1051	998 / 1051

Piston Kit Part No.	Piston size (mm)	Over size (mm)	Ring Set Part No.	Piston Kit Part No.	Piston size (mm)	Over size (mm)	Ring Set Part No.	Piston Kit Part No.	Piston size (mm)	Over size (mm)	Ring Set Part No.
K8767DA-4	75,94	Std.	760XAS	K8746DA-4	75,94	Std.	760XWY	K8767DA-4	75,94	Std.	760XAS
K8767D200-4	77,94	+2,0	780XAS	K8746D200-4	77,94	+2,0	780XWY	K8767D200-4	77,94	+2,0	780XAS
K8767D400-4	79,94	+4,0	800XAS	K8746D300-4	78,94	+3,0	790XKS	K8767D400-4	79,94	+4,0	800XAS

set includes			
Clip Part No.	CW17	CW17	CW17
Pin Part No.	WP090	WP083	WP090
Rings	included	included	included
Price-Code	10/1	10/1	10/1
Stroke	55	55	55
Wössner/ OEM Comp. ratio	10:1 12.7:1	13.7:1 12.9:1	10.3:1 12.9:1
Dome Volume (CC)	-9.3 cm <sup>3</sup>	-1.8 cm <sup>3</sup>	-9.3 cm <sup>3</sup>
Comp. Height (mm)	22.7	22.7	22.7

extra parts			
Top End Gasket Kit	-	C8576	-
Wössner Connecting rods	-	-	-
Needle bearing	-	-	-
Main bearing	-	-	-

## Kawasaki® - 4 stroke



Verdichtungen beziehen sich auf Standardmaße „-DA“

Compression ratio refer to standard sizes “-DA”

<b>Model</b>	ZX10R	KZ1000J / KZ1000R	KZ1000 / KZ1000ST / Z1R / Z2R
<b>Years</b>	11-14	81-83	thru 80 / thru 80 / 77-80 / 77-80
<b>Displ. (cc)</b>	998	1075 / 1105	1045 / 1075

Piston Kit Part No.	Piston size (mm)	Over size (mm)	Ring Set Part No.	Piston Kit Part No.	Piston size (mm)	Over size (mm)	Ring Set Part No.	Piston Kit Part No.	Piston size (mm)	Over size (mm)	Ring Set Part No.
K8832DA-4	75,94	Std.	760XAS	K8796D250-4	71,94	+2,5	720XDS	K8797D100-4	70,94	+1,0	710XDS
K8832D200-4	77,94	+2,0	780XAS	K8796D350-4	72,94	+3,5	730XDS	K8797D200-4	71,94	+2,0	720XDS
K8832D300-4	78,94	+3,0	790XAS								

	set includes		
<b>Clip Part No.</b>	CW17	CW17	CW17
<b>Pin Part No.</b>	WP083	WP083	WP083
<b>Rings</b>	included	included	included
<b>Price-Code</b>	10	10	10
<b>Stroke</b>	55	66	66
<b>Wössner/ OEM Comp. ratio</b>	13.5:1 13:1	10.25:1 / 10.5:1 9.2:1	10:1 8.7:1
<b>Dome Volume (CC)</b>	DA = -3 cm <sup>3</sup> D200 / D300 = -3.8 cm <sup>3</sup>	18.75 cm <sup>3</sup>	+10 cm <sup>3</sup>
<b>Comp. Height (mm)</b>	22.7	25.3	24.7

	extra parts		
<b>Top End Gasket Kit</b>	-	C8325	C8018
<b>Wössner Connecting rods</b>	-	-	-
<b>Needle bearing</b>	-	-	-
<b>Main bearing</b>	-	-	-

## Kawasaki® - 4 stroke



Verdichtungen beziehen sich auf Standardmaße „-DA“

Compression ratio refer to standard sizes “-DA”

Model	GPZ1100 17mm Pin	KZ1100 / GPZ1100 / GPZX1100 / ZX1100 18mm Pin	ZX11 C1 / ZX11 D1 / ZZR1100 / ZRX1100 / GPZ1100
Years	81-82	83-84	90-94 / 93-01 / 90-01 / 97-01 / 95-97
Displ. (cc)	1135 / 1166	1170 / 1262	1109

Piston Kit Part No.	Piston size (mm)	Over size (mm)	Ring Set Part No.	Piston Kit Part No.	Piston size (mm)	Over size (mm)	Ring Set Part No.	Piston Kit Part No.	Piston size (mm)	Over size (mm)	Ring Set Part No.
K8819D150-4	73,94	+1,5	740XDS	K8798D250-4	74,94	+2,5	750XDS	K8800D200-4	77,94	+2,0	780XDS
K8819D250-4	74,94	+2,5	750XDS	K8798D550-4	77,94	+5,5	780XDS				

	set includes		
Clip Part No.	CW17	CW18	CW18
Pin Part No.	WP083	WP031	WP099
Rings	included	included	included
Price-Code	10	10	10
Stroke	66	66.2	58
Wössner/ OEM Comp. ratio	10.25:1 / 10.5:1 8.9:1	10.25:1 / 11:1 9.5:1	11.8:1 10.1:1
Dome Volume (CC)	+16.5 cm <sup>3</sup>	+16.2 cm <sup>3</sup>	-3.9 cm <sup>3</sup>
Comp. Height (mm)	25.3	25.6	24.4

	extra parts		
Top End Gasket Kit	C8020	-	-
Wössner Connecting rods	-	-	-
Needle bearing	-	-	-
Main bearing	-	-	-

## Kawasaki® - 4 stroke



Verdichtungen beziehen sich auf Standardmaße „-DA“  
 Compression ratio refer to standard sizes “-DA”

Model	ZX11	ZX12 Turbo	ZX14 Pro Series
Years	90-01	00-05	06-09
Displ. (cc)	1080 / 1109	1198 / 1257	1352

Piston Kit Part No.	Piston size (mm)	Over size (mm)	Ring Set Part No.	Piston Kit Part No.	Piston size (mm)	Over size (mm)	Ring Set Part No.	Piston Kit Part No.	Piston size (mm)	Over size (mm)	Ring Set Part No.
K8801D100-4	76,95	+1,0	770XDS	K8779DA-4	82,93	Std.	830XTY	K8785DA-4	83,93	Std.	840XDS
K8801D200-4	77,95	+2,0	780XDS	K8779D200-4	84,93	+2,0	850XTY	K8785D200-4	85,93	+2,0	860XDS
								K8785D300-4	86,93	+3,0	870XDS

	set includes		
Clip Part No.	-	CW21	CW20
Pin Part No.	-	WP092	WP038
Rings	included	included	included
Price-Code	10	10	10/1
Stroke	58	55.4	61
Wössner/ OEM Comp. ratio	- 11:1	9.8:1 12.2:1	13.5:1 12:1
Dome Volume (CC)	-	-9.8 cm <sup>3</sup>	DA - D200 = -2.4 cm <sup>3</sup> D300 = -3.7 cm <sup>3</sup>
Comp. Height (mm)	24.4	25.0	24.5

	extra parts		
Top End Gasket Kit	C8273	-	-
Wössner Connecting rods	-	-	KPM007
Needle bearing	-	-	-
Main bearing	-	-	-

## Kawasaki® - 4 stroke



Verdichtungen beziehen sich auf Standardmaße „-DA“  
 Compression ratio refer to standard sizes “-DA”

Model	ZX14 Turbo
Years	06-09
Displ. (cc)	1352

Piston Kit Part No.	Piston size (mm)	Over size (mm)	Ring Set Part No.
K8780DA-4	83,93	Std.	840XDS
K8780D200-4	85,93	+2,00	860XDS
K8780D300-4	86,93	+3,00	870XDS

set includes	
Clip Part No.	CW20
Pin Part No.	WP065
Rings	included
Price-Code	10/1
Stroke	61
Wössner/ OEM Comp. ratio	9:1 12:1
Dome Volume (CC)	DA - D200 = -18 cm <sup>3</sup> D300 = -21 cm <sup>3</sup>
Comp. Height (mm)	24.5

extra parts	
Top End Gasket Kit	KPM007
Wössner Connecting rods	-
Needle bearing	-
Main bearing	-



Bernd Hiemer  
 Team Bauerschmidt KTM

## Sachs® - 2 stroke



<b>Model</b>	Sachs 125/6 <b>New!</b>	Sachs 125/7 <b>New!</b>
<b>Years</b>	-	-
<b>Displ. (cc)</b>	122,5	122,5

Piston Kit Part No.	Piston size (mm)	Over size (mm)	Ring Set Part No.	Piston Kit Part No.	Piston size (mm)	Over size (mm)	Ring Set Part No.
8286D050	54,44	+0,50	RDB5450	8287D050	54,19	+0,50	RSB5425
8286D100	54,94	+1,00	RDB5500	8287D100	54,69	+1,00	RSB5475
8286D150	55,44	+1,50	RDB5550	8287D150	55,19	+1,50	RSB5525
8286D200	55,94	+2,00	RDB5600	8287D200	55,69	+2,00	RSB5575

set includes		
<b>Clip Part No.</b>	CW15	CW16
<b>Pin Part No.</b>	WP032	WP036
<b>Rings</b>	included	included
<b>Price-Code</b>	2	2
<b>Stroke</b>	54	54
<b>Wössner/ OEM Comp. ratio</b>	-	-
<b>Comp. Height (mm)</b>	38	38

extra parts		
<b>Top End Gasket Kit</b>	-	-
<b>Wössner Connecting rods</b>	-	-
<b>Needle bearing</b>	-	-
<b>Main bearing</b>	-	-



## Suzuki® - 2 stroke



<b>Model</b>	T500 / GT500 Twin Cylinder	GT-750
<b>Years</b>	-	-
<b>Displ. (cc)</b>	492	750

Piston Kit Part No.	Piston size (mm)	Over size (mm)	Ring Set Part No.	Piston Kit Part No.	Piston size (mm)	Over size (mm)	Ring Set Part No.
K8276DA-2	69,91	Std.	RDB7000	K8276DA-3	69,91	Std.	RDB7000
K8276D050-2	70,41	+0,5	RDB7050	K8276D050-3	70,41	+0,5	RDB7050
K8276D100-2	70,91	+1,0	RDB7100	K8276D100-3	70,91	+1,0	RDB7100
K8276D150-2	71,41	+1,5	RDB7150	K8276D150-3	71,41	+1,5	RDB7150
K8276D200-2	71,91	+2,0	RDB7200	K8276D200-3	71,91	+2,0	RDB7200

set includes		
<b>Clip Part No.</b>	CW18	CW18
<b>Pin Part No.</b>	WP033	WP033
<b>Rings</b>	included	included
<b>Price-Code</b>	3/2K	3/3K
<b>Stroke</b>	64	64
<b>Comp. Height (mm)</b>	31.8	31.8

extra parts		
<b>Top End Gasket Kit</b>	-	-
<b>Wössner Connecting rods</b>	-	-
<b>Needle bearing</b>	-	-
<b>Main bearing</b>	-	-

## Suzuki® - 4 stroke



Verdichtungen beziehen sich auf Standardmaße „-DA“  
 Compression ratio refer to standard sizes “-DA”

Model	GSXR750	GSXR750 / GSXR750F Katana	GSXR750 Oil / Air cooled models
Years	85-87	88-89 / 89-97	90-91
Displ. (cc)	771	771	771

Piston Kit Part No.	Piston size (mm)	Over size (mm)	Ring Set Part No.	Piston Kit Part No.	Piston size (mm)	Over size (mm)	Ring Set Part No.	Piston Kit Part No.	Piston size (mm)	Over size (mm)	Ring Set Part No.
K8836D100-4	70,94	+1,0	710XDS	K8817D100-4	73,94	+1,0	740XAS	K8837D100-4	70,94	+1,0	710XDS

set includes			
Clip Part No.	-	CW19	-
Pin Part No.	-	WP028	-
Rings	included	included	included
Price-Code	10	10	10
Stroke	48.7	44.7	48.7
Wössner/ OEM Comp. ratio	- 11:1	11.7:1 10.9:1	- 10.9:1
Dome Volume (CC)	-	+5.7 cm <sup>3</sup>	-
Comp. Height (mm)	-	23.8	-

extra parts			
Top End Gasket Kit	-	C8415	-
Wössner Connecting rods	-	-	-
Needle bearing	-	-	-
Main bearing	-	-	-

## Suzuki® - 4 stroke



Verdichtungen beziehen sich auf Standardmaße „-DA“  
 Compression ratio refer to standard sizes “-DA”

Model	GSX1100E	GSXR1100 / GSF1200 Bandit / GSXR1100F Katana	GSXR1000
Years	80-83	89-92 / 89-92 / 89-92	01-04
Displ. (cc)	1134	1165 / 1194 / 1224 / 1254 / 1315	988

Piston Kit Part No.	Piston size (mm)	Over size (mm)	Ring Set Part No.	Piston Kit Part No.	Piston size (mm)	Over size (mm)	Ring Set Part No.	Piston Kit Part No.	Piston size (mm)	Over size (mm)	Ring Set Part No.
K8838D200-4	73,94	+2,0	740XDS	K8530D200-4	79,94	+2,0	800XDS	K8754DA-4	72,96	Std.	730XDS
				K8530D300-4	80,94	+3,0	810XSY				
				K8530D400-4	81,94	+4,0	820XSY				
				K8530D500-4	82,94	+5,0	830XSY				
				K8530D700-4	84,94	+7,0	850XSY				

	set includes		
Clip Part No.	CW18	CW20	CW16
Pin Part No.	WP054	WP029	WP059
Rings	included	included	included
Price-Code	10	10	10
Stroke	66	58	59
Wössner/ OEM Comp. ratio	9.5:1 9.5:1	- 9.5:1	14:1 12:1
Dome Volume (CC)	-1.0 cm <sup>3</sup>	+3.8 cm <sup>3</sup>	-4.4 cm <sup>3</sup>
Comp. Height (mm)	27.2	25.30	22.55

	extra parts		
Top End Gasket Kit	-	C8279	-
Wössner Connecting rods	-	-	KPM005
Needle bearing	-	-	-
Main bearing	-	-	-

## Suzuki® - 4 stroke



Verdichtungen beziehen sich auf Standardmaße „-DA“  
 Compression ratio refer to standard sizes “-DA”

\* OEM rings must be used

Model	GSXR1000 Turbo	GSXR1000	GSXR1000 Turbo
Years	01-04	05-08	05-08
Displ. (cc)	988 / 1042	998,6 / 1024 / 1070	998,6 / 1042 / 1070

Piston Kit Part No.	Piston size (mm)	Over size (mm)	Ring Set Part No.	Piston Kit Part No.	Piston size (mm)	Over size (mm)	Ring Set Part No.	Piston Kit Part No.	Piston size (mm)	Over size (mm)	Ring Set Part No.
K8755DA-4	72,96	Std.	730XAS	K8700DA-4	73,36	Std.	OEM*	K8747DA-4	73,36	Std.	OEM*
K8755D200-4	74,96	+2,0	750XKS	K8700D160-4	74,96	+1,6	750XDS	K8747D160-4	74,96	+1,6	750XKS
				K8700D260-4	75,96	+2,6	760XDS	K8747D260-4	75,96	+2,6	760XAS

	set includes		
Clip Part No.	CW16	CW15	CW15
Pin Part No.	WP059	WP011	WP011
Rings	included	included	included
Price-Code	10	10	10
Stroke	59	59	59
Wössner/ OEM Comp. ratio	10:1 12:1	14:1 / 14.6:1 / 14.9:1 12.5:1	10:1 12.5:1
Dome Volume (CC)	-12.1 cm <sup>3</sup>	-4.4 cm <sup>3</sup>	-12.5 cm <sup>3</sup>
Comp. Height (mm)	22.55	22.50	22.5

	extra parts		
Top End Gasket Kit	-	-	-
Wössner Connecting rods	KPM005	KPM006	KPM006
Needle bearing	-	-	-
Main bearing	-	-	-

## Suzuki® - 4 stroke



Verdichtungen beziehen sich auf Standardmaße „-DA“

Compression ratio refer to standard sizes “-DA”

\* OEM rings must be used

Model	GSXR1000	GSXR1000 Turbo	Hayabusa HC / 3. Ring
Years	09-15	09-14	99-07
Displ. (cc)	999 / 1052	999	1299 / 1395 / 1429

Piston Kit Part No.	Piston size (mm)	Over size (mm)	Ring Set Part No.	Piston Kit Part No.	Piston size (mm)	Over size (mm)	Ring Set Part No.	Piston Kit Part No.	Piston size (mm)	Over size (mm)	Ring Set Part No.
K8790DA-4	74,46	Std.	OEM*	K8794DA-4	74,46	Std.	-	K8730DA-4	80,95	Std.	810XDS
K8790D200-4	76,46	+2,0	OEM*					K8730D300-4	83,95	+3,0	840XDS
								K8730D400-4	84,95	+4,0	850XDS

	set includes		
Clip Part No.	CW15	CW15	CW20
Pin Part No.	WP011	-	WP029
Rings	included	included	included
Price-Code	10	10	10
Stroke	57.3	57.3	63
Wössner/ OEM Comp. ratio	14:1 12.8:1	10:1 12.8:1	13.5:1 11:1
Dome Volume (CC)	-4.4 cm <sup>3</sup>	-4.6 cm <sup>3</sup>	-3.3 cm <sup>3</sup>
Comp. Height (mm)	22.35	22.35	25.1

	extra parts		
Top End Gasket Kit	-	-	G0001
Wössner Connecting rods	-	-	KPM002
Needle bearing	-	-	-
Main bearing	-	-	-

## Suzuki® - 4 stroke



Verdichtungen beziehen sich auf Standardmaße „-DA“  
 Compression ratio refer to standard sizes “-DA”

Model	Hayabusa Turbo	Hayabusa HC / 3. Ring	Hayabusa Turbo
Years	99-07	08-14	08-14
Displ. (cc)	1299 / 1362	1340 / 1406 / 1440 / 1474	1340 / 1406

Piston Kit Part No.	Piston size (mm)	Over size (mm)	Ring Set Part No.	Piston Kit Part No.	Piston size (mm)	Over size (mm)	Ring Set Part No.	Piston Kit Part No.	Piston size (mm)	Over size (mm)	Ring Set Part No.
K8734DA-4	80,93	Std.	810XDS	K8733DA-4	80,95	Std.	810XDS	K8736DA-4	80,92	Std.	810XDS
K8734D200-4	82,93	+2,0	830XDS	K8733D200-4	82,95	+2,0	830XDS	K8736D200-4	82,92	+2,0	830XDS
				K8733D300-4	83,95	+3,0	840XDS				
				K8733D400-4	84,95	+4,0	850XDS				

	set includes		
Clip Part No.	CW20	CW18	CW18
Pin Part No.	WP065	WP054	WP064
Rings	included	included	included
Price-Code	10	10	10
Stroke	63	65	65
Wössner/ OEM Comp. ratio	9:1 11:1	13.5:1 12.5:1	9:1 12.5:1
Dome Volume (CC)	-17.5 cm <sup>3</sup>	-4.2 cm <sup>3</sup> / -5.1 cm <sup>3</sup> / -5.7 cm <sup>3</sup>	-19.3 cm <sup>3</sup>
Comp. Height (mm)	26.8	24	24

	extra parts		
Top End Gasket Kit	G0001	G0001	G0001
Wössner Connecting rods	KPM002	KPM003	KPM003
Needle bearing	-	-	-
Main bearing	-	-	-

## Yamaha® - 4 stroke



Verdichtungen beziehen sich auf Standardmaße „-DA“

Compression ratio refer to standard sizes “-DA”

Model	XS650	R1 / FZR / RX1	R1 - YZF1000
Years	74-81	99-03 / 01-05	04-06
Displ. (cc)	679 / 688	998 / 1024 / 1051	998 / 1023

Piston Kit Part No.	Piston size (mm)	Over size (mm)	Ring Set Part No.	Piston Kit Part No.	Piston size (mm)	Over size (mm)	Ring Set Part No.	Piston Kit Part No.	Piston size (mm)	Over size (mm)	Ring Set Part No.
K8818D150-2	76,44	+1,5	765XDS	K8840DA-4	73,95	Std.	740XDS	K8752DA-4	76,96	Std.	770XAS-2
K8818D200-2	76,94	+2,0	770XDS	K8840D100-4	74,95	+1,0	750XDS	K8752D100-4	77,96	+1,0	780XAS-2
				K8840D200-4	75,95	+2,0	760XDS				

	set includes		
Clip Part No.	CW20	CW17	CW17
Pin Part No.	WP068	WP083	WP083
Rings	included	included	included
Price-Code	9	9	9
Stroke	74	58	53.6
Wössner/ OEM Comp. ratio	- 8.4:1	10.2:1 11.8:1	13.5:1 12.5:1
Dome Volume (CC)	+23.4 cm <sup>3</sup>	-2.6 cm <sup>3</sup>	-4.7 cm <sup>3</sup>
Comp. Height (mm)	29	22.8	22.8

	extra parts		
Top End Gasket Kit	-	-	-
Wössner Connecting rods	-	-	-
Needle bearing	-	-	-
Main bearing	-	-	-

## Yamaha® - 4 stroke



Verdichtungen beziehen sich auf Standardmaße „-DA“

Compression ratio refer to standard sizes “-DA”

Model	R1 - YZF1000	YZF1000 R1	FZR1000R EXUP
Years	07-08	09-14	89-96
Displ. (cc)	998	998	1042

Piston Kit Part No.	Piston size (mm)	Over size (mm)	Ring Set Part No.	Piston Kit Part No.	Piston size (mm)	Over size (mm)	Ring Set Part No.	Piston Kit Part No.	Piston size (mm)	Over size (mm)	Ring Set Part No.
K8753DA-4	76,96	Std.	RIK77.00D3	K8812DA-4	77,96	Std.	780XAS	K8529D150-4	76,93	+1,5	RIK77.00D3

set includes			
Clip Part No.	CW17	CW17	CW19
Pin Part No.	WP083	WP083	WP028
Rings	included	included	included
Price-Code	9	10	10
Stroke	53.6	52.2	56
Wössner/ OEM Comp. ratio	13.5:1 12.7	12.7:1 12.7:1	12:1 11.2:1
Dome Volume (CC)	-3.3 cm <sup>3</sup>	-3.3 cm <sup>3</sup>	+2.0 cm <sup>3</sup>
Comp. Height (mm)	22.8	22.8	23

extra parts			
Top End Gasket Kit	-	-	C8283
Wössner Connecting rods	-	-	-
Needle bearing	-	-	-
Main bearing	-	-	-



## Yamaha® - 4 stroke



Verdichtungen beziehen sich auf Standardmaße „-DA“  
 Compression ratio refer to standard sizes “-DA”

<b>Model</b>	YZF R6	YZF R6
<b>Years</b>	01-05	06-11
<b>Displ. (cc)</b>	600 / 617 / 636	599 / 617 / 635

Piston Kit Part No.	Piston size (mm)	Over size (mm)	Ring Set Part No.	Piston Kit Part No.	Piston size (mm)	Over size (mm)	Ring Set Part No.
K8831DA-4	65,44	Std.	655XKS	K8830DA-4	66,94	Std.	670XKS
K8831D100-4	66,44	+1,00	665XKS	K8830D100-4	67,94	+1,00	680XKS
K8831D200-4	67,44	+2,00	675XKS	K8830D200-4	68,94	+2,00	690XKS

set includes		
<b>Clip Part No.</b>	CW16	CW15
<b>Pin Part No.</b>	WP036	WP011
<b>Rings</b>	included	included
<b>Price-Code</b>	10	10
<b>Stroke</b>	44.5	42.5
<b>Wössner/ OEM Comp. ratio</b>	12.4:1 12.4:1	- 13:1
<b>Dome Volume (CC)</b>	-0.1 cm <sup>3</sup>	-2 cm <sup>3</sup>
<b>Comp. Height (mm)</b>	21.2	21.2

extra parts		
<b>Top End Gasket Kit</b>	-	-
<b>Wössner Connecting rods</b>	-	-
<b>Needle bearing</b>	-	-
<b>Main bearing</b>	-	-

## GM® - 4 stroke



Verdichtungen beziehen sich auf Standardmaße „-DA“  
 Compression ratio refer to standard sizes “-DA”

<b>Model</b>	-
<b>Years</b>	all
<b>Displ. (cc)</b>	499

Piston Kit Part No.	Piston size (mm)	Over size (mm)	Ring Set Part No.
8811DA	89,93	Std.	900ADS-2
8811DC	89,95	+0,02	900ADS-2
8811DE	89,97	+0,04	900ADS-2
<b>Kurzhub / Short stroke:</b>			
8811D200A	91,93	+2,00	920ADS-2
8811D200C	91,95	+2,02	920ADS-2
8811D200E	91,97	+2,04	920ADS-2

	set includes
<b>Clip Part No.</b>	CW21
<b>Pin Part No.</b>	WP074
<b>Rings</b>	included
<b>Price-Code</b>	25
<b>Stroke</b>	78.5
<b>Wössner/ OEM Comp. ratio</b>	-
<b>Dome Volume (CC)</b>	+5.6 cm <sup>3</sup>
<b>Comp. Height (mm)</b>	22

	extra parts
<b>Top End Gasket Kit</b>	-
<b>Wössner Connecting rods</b>	-
<b>Needle bearing</b>	-
<b>Main bearing</b>	-

Sie finden in unserem Sortiment neuentwickelte Kolben speziell für Bahnmotoren. Die Leidenschaft für den Bahnsport führte Eckart Wössner, der lange in diesem Sport aktiv war, dazu Kolben speziell für diese Motoren zu entwickeln. Jeder am Bahnsport Interessierte weiß, dass diese Kolben die am stärksten belasteten Kolben im Rennsport sind. Um dieser hohen Belastung von bis zu 14000 Umdrehung am Start standhalten zu können, wurden spezielle Rohteile mit einer besonderen Wärmebehandlung entwickelt und produziert. Diese Neuentwicklung soll Fahrer und Sport weiter voranbringen. Die neuentwickelten Wössner Kolben werden unter anderem in den Speedwaymotoren von Joonas Kylmäkorpi und Richard Speiser verbaut – mit hervorragenden Ergebnissen. Auch Marcel Gerhard und Joachim Kugelmann setzten auf die neuen Wössner Kolben in ihren extrem getunten Motoren. Die neuen Schmiedekolben liefern die nötige Power.

*You can find the newly developed pistons especially for speedway engines as part of our range of products. The passion for speedway races has lead Eckart Wössner, who himself was engaged in this sport for a long time, to develop pistons especially for these engines. Everyone interested in speedway knows that these pistons are the most loaded pistons in racing. To be able to withstand this high pressure of up to 14000 rotations at the start, a special forging with a specific heat treatment have been developed and produced. This new development should bring the riders and the sport a step further. The newly developed Wössner pistons are getting installed among others in the speedway engines of Joonas Kylmäkorpi and Richard Speiser – with excellent results. Marcel Gerhard and Joachim Kugelmann count on the new Wössner pistons for there extremely good tuned engines too. The new forged pistons provide the necessary power.*

Joonas Kylmäkorpi – Langbahnmeister 2010/11/12/13  
 Long Track Champion 2010/11/12/13

Photo: Wolfgang Radzuzweit



## Pleuel • Conrods - 2 stroke

Alle Sets beinhalten Bolzen, Nadellager, Hauptlager und Unterlagsscheiben  
All sets includ crankshaft pin, needle bearing, main bearing and washer



	PART No	Fits Modell	Year	Price code
APRILIA	P2051	RS, AF1 125	88-89	P3
GAS GAS	P2021	MC250	97-14	P4
	P2021	EC250	97-14	P4
HONDA	P2003	CR80	86-02	P2
	P2003	CR85	03-07	P2
	P2040	CR125	83-84	P3
	P2041	CR125	85-87	P3
	P2009	CR125	88-07	P3
	P2021	CR250	78-01	P4
	P2020	CR250	02-07	P4
	P2021	ATC250	85-86	P4
	P2042	ATC250	87-89	P4
	P2021	TRX250	86	P4
	P2042	TRX250	87-89	P4
	P2044	CR500	87-01	P4
HUSABERG	P2012	TE125	12-13	P3
	P2023	TE250	11-13	P4
	P2023	TE300	11-14	P4
HVA	P2060	CR/WR/WRE/ SM/SMS 125	97-13	P3
	P2060	CR150	11	P3
	P2057	CR/WR250	99-13	P4
	P2023	TC300	14	P4
KAWASAKI	P2001	KX60	83-03	P1
	P2001	KX65	00-14	P1
	P2036	KX80	82-97	P2
	P2005	KX80	98-00	P2
	P2036	KDX80	82-88	P2
	P2005	KX85	01-14	P2
	P2036	KX100	95-97	P2
	P2005	KX100	98-13	P2
	P2037	KX125	78-87	P3

	PART No	Fits Modell	Year	Price code
KAWASAKI	P2033	KX125	88-91	P3
	P2037	KX125	92-93	P3
	P2034	KX125	98-02	P3
	P2010	KX125	03-08	P3
	P2037	KDX200	86-87	P3
	P2033	KDX200	89-06	P4
	P2033	KDX220	97-05	P4
	P2022	KX250	78-08	P4
	P2022	KDX250	91-94	P4
	P2039	KX500	85-04	P4
KTM	P2053	SX50	01-14	P1
	P2054	SX60	97-02	P1
	P2054	SX65	00-02	P1
	P2002	SX65	03-08	P1
	P2055	SX65	09-14	P1
	P2055	XC65	09	P1
	P2006	SX85	03-12	P2
	P2065	SX85	13-14	P2
	P2006	SX105	04-11	P2
	P2056	SX125	89-97	P3
	P2011	SX125	98-06	P3
	P2012	SX125	07-14	P3
	P2012	SXS125	08	P3
	P2056	EXC125	89-97	P3
	P2011	EXC125	98-06	P3
	P2012	EXC125	07-14	P3
	P2012	SX144	07-08	P3
	P2012	SX150	09-14	P3
P2031	XC200	98-10	P4	
P2031	XC-W200	98-13	P4	
P2031	EXC200	98-14	P4	

## Pleuel • Conrods - 2 stroke

Alle Sets beinhalten Bolzen, Nadellager, Hauptlager und Unterlagsscheiben  
All sets includ crankshaft pin, needle bearing, main bearing and washer



	PART No	Fits Modell	Year	Price code
KTM	P2031	SX200	03-05	P4
	P2058	SX250	00-02	P4
	P2024	EXC250	90-99	P4
	P2058	EXC250	00-03	P4
	P2023	EXC250	04-14	P4
	P2023	SX250	04-14	P4
	P2024	EXC300	90-03	P4
	P2024	GS300	91-94	P4
	P2024	MX300	91-94	P4
	P2024	GS300	95	P4
	P2024	MX300	95	P4
	P2023	EXC300	04-14	P4
	P2023	MXC300	04-08	P4
	SUZUKI	P2001	RM60	03
P2001		RM65	03-05	P1
P2059		RM80	86-89	P2
P2007		RM85	02-14	P2
P2005		RM100	03	P2
P2040		RM125	84-86	P3
P2015		RM125	87-96	P3
P2014		RM125	97-98	P3

	PART No	Fits Modell	Year	Price code
SUZUKI	P2013	RM125	99-03	P3
	P2016	RM125	04-07	P3
	P2027	RM250	89-95	P4
	P2026	RM250	96-02	P4
	P2025	RM250	03-08	P4
	P2027	RMX 250	89-00	P4
	YAMAHA	P2008	YZ80	93-01
P2008		YZ85	02-14	P2
P2047		YZ125	86-96	P3
P2019		YZ125	97-00	P3
P2017		YZ125	01-04	P3
P2018		YZ125	05-14	P3
P2050		DT125R / TZR125	all	P3
P2030		YFS200 Blaster	88-06	P4
P2048		YZ250	83-89	P4
P2029		YZ250	90-98	P4
P2028	YZ250	99-14	P4	
P2035	RD, YFZ350 Banshee	87-06	P4	
P2049	YZF350 Banshee stroker rod	87-06	P4	

## Pleuel • Conrods - 4 stroke

Alle Sets beinhalten Bolzen, Nadellager, Hauptlager und Unterlagsscheiben  
*All sets includ crankshaft pin, needle bearing, main bearing and washer*

\*inkl. Lagerschalen

*\*incl. bearing shells*

	PART No	Fits Modell	Year	Price code
GAS GAS	P4005	EC250F	10-14	P5
HONDA	P4024	CRF150	07-14	P3
	P4053	CRF230	03-14	P5
	P4001	CRF250R	04-14	P5
	P4001	CRF250X	04-14	P5
	P4025	XR250	86-04	P5
	P4021	TRX400EX	99-08	P6
	P4021	TRX400X	09-13	P6
	P4033	XR400R	96-04	P6
	P4022	TRX420FE	07-11	P6
	P4023	TRX450R	06-14	P6
	P4023	TRX450ER (ATV)	06-13	P6
	P4023	CRF450X	05-13	P6
	P4026	CRF450R	02-08	P6
	P4027	CRF450R	09-14	P6
	P4028	XK600	83-87	P7
	P4028	XR600	85-01	P7
	P4028	XL600R	83-87	P7
P4056	XR650R	00-07	P7	
HVA	P4049	TC250	06-09	P5
	P4050	TC250	10-13	P5
	P4049	TC/TE 310	09-10	P5
	P4054	TC510	06-09	P7
	P4054	TE / TXC / SMR 510	08-10	P7
	P4042	TC/TE570	99-10	P7
	P4041	TE610	91-98	P7
	P4042	TE610	99-10	P7
KAWASAKI	P4002	KX250F	04-09	P5
	P4039	KX250F 2x0,5mm Washers	10-14	P5

	PART No	Fits Modell	Year	Price code
KAWASAKI	P4009	KLX400R	03-04	P6
	P4009	KFX400	03-06	P6
	P4010	KX450F	07-08	P6
	P4019	KFX450R	08-14	P6
	P4020	KX450F	09-14	P6
KTM	P4003	SX250F	05-12	P5
	P4059*	SX250F	13-14	P6.1
	P4048	EXC250 Racing	01-06	P5
	P4003	EXC250 Racing	06-12	P5
	P4040	SX-F350	10-12	P5
	P4061*	SX-F350	13-14	P6.1
	P4014	LC4	03-07	P7
	P4048	SX400	00-02	P5
	P4048	EXC400	04-06	P5
	P4015	SX450	03-06	P6
	P4015	SX-F450	05-06	P6
	P4015	SMR	04-07	P6
	P4048	EXC450 Racing	03-07	P5
	P4016	EXC450R	08-11	P6
	P4057*	EXC450	12-14	P6.1
	P4017	SX-F450	07-12	P6
	P4058*	SX-F450	13-14	P6.1
	P4051	EXC500	12-13	P7
	P4055	SX-F505	08	P7
	P4055	505XCF / SX ATV	09	P7
	P4048	EXC520	00-02	P5
	P4048	SX520	00-02	P5
	P4048	EXC525 Racing	03-07	P5
P4048	SX525 Racing	03-07	P5	
P4047	EXC530R	08-11	P6	

## Pleuel • Conrods - 4 stroke

Alle Sets beinhalten Bolzen, Nadellager, Hauptlager und Unterlagsscheiben  
All sets include crankshaft pin, needle bearing, main bearing and washer



	PART No	Fits Modell	Year	Price code
KTM	P4014	620/625/640LC4 SX/Duke/ Supermoto	03-07	P7
	P4014	660SMC	03-07	P7
SUZUKI	P4034	LT230	87-94	P5
	P4002	RMZ250	04-06	P5
	P4004	RMZ250	07-14	P5
	P4009	DR-Z400E/S	00-08	P6
	P4009	LTZ400	03-09	P6
	P4011	LTR450	06-09	P6
	P4012	RMZ450	05-07	P6
	P4013	RMZ450	08-14	P6
	P4045	King Quad 700		P7
	YAMAHA	P4006	YZF250	01-02
P4005		YZF250	03-13	P5
P4063		YZF250	14	TBA
P4005		WR250F	03-13	P5

	PART No	Fits Modell	Year	Price code
YAMAHA	P4036	YFM350 Warrior	87-04	P5
	P4036	YFM350 Raptor	04-13	P5
	P4007	YZF450	03-05	P6
	P4008	YZF450	06-09	P6
	P4007	WRF450	03-06	P6
	P4029	YFZ450	04-05	P6
	P4030	YFZ450	06-14	P6
	P4032	YZF450	10-14	P6
	P4037	YFM660 Raptor	01	P7
	P4038	YFM660 Raptor	02-05	P7
	P4038	YFM660 Grizzly	02-08	P7
	P4038	YFM660 Rhino	04-07	P7
	P4031	YFM700 Raptor	06-09	P7
	Bombardier	P5201	Mach Z1000	05-07
Arctic Cat	P5202	F-1000 F7-F8-M8	-	-
	P5203	Thundercat 1000 F7-F8-M8	-	-



## Nadellager • Needle Bearings



	PART No	Fits Modell	Year	Dimension	Price code
APRILLIA	N1010	RS125	all	15x19x19.5	N1
	N1012	RS250	all	16x20x17.3	N1
CAGIVA	N1014	Mito125	all	16x20x22.5	N1
	N1014	125 W8	all	16x20x22.5	N1
GASGAS	N1011	EC125	00-11	15x20x17.8	N1
	N1020	EC200	all	18x22x19.8	N1
	N1021	EC250	97-11	18x22x21.8	N1
	N1021	EC300	00-11	18x22x21.8	N1
HONDA	N1004	TC80	70 - 78	12x17x14.2	N1
	N1004	CR80	80-85	12x17x14.2	N1
	N1006	CR80	86-02	14x18x16.5	N1
	N1006	CR80R	86-02	14x18x16.5	N1
	N1004	MTX80	alle	12x17x14.2	N1
	N1006	CR85R	03-06	14x18x16.5	N1
	N1006	CR85	03-07	14x18x16,5	N1
	N1008	MT125	73-78	14x18x19.8	N1
	N1047	RS125	95-04	15x19x17.3	N1
	N1008	CR125	73-84	14x18x19.8	N1
	N1007	CR125	85-86	14x18x17.2	N1
	N1008	CR125M	73-78	14x18x19.8	N1
	N1008	CR125R	79-84	14x18x19.8	N1
	N1008	CR125	87	14x18x19.8	N1
	N1008	CR125R	87	14x18x19.8	N1
	N1047	CR125	88-07	15x19x17.3	N1
	N1047	CR125R	88-07	15x19x17.3	N1
	N1047	CR150	11	15x19x17.3	N1
	N1021	CR250	73-07	18x22x21.8	N1
	N1020	CR250R	78-07	18x22x19.8	N1
	N1020	CR250M	73-77	18x22x19.8	N1
	N1030	CR480R	82-83	20x25x27.8	N1
	N1030	CR500R	84-01	20x25x27.8	N1
N1021	ARC250	81-86	18x22x21.8	N1	

## Nadellager • Needle Bearings



	PART No	Fits Modell	Year	Dimension	Price code
HONDA	N1020	ATC250R	81-84	18x22x19.8	N1
	N1020	ATC250R	85-86	18x22x19.8	N1
	N1020	TRX250R Four Trax	86-89	18x22x19.8	N1
	N1021	TRX250R	87-89	18x22x21.8	N1
	N1030	CR500	84-01	20x25x27.8	N1
	N1013	NSR 125	all	16x20x19.5	N1
HUSABERG	N1010	TE125	12	15x19x19.5	N1
	N1020	TE250	11-12	18x22x19.8	N1
	N1020	TE300	11-12	18x22x19.8	N1
HUSQVARNA	N1014	CR/WR125	92-96	16x20x22.5	N1
	N1047	CR/WR/WER/SM/SMS125	97-12	15x19x17.3	N1
	N1021	CR/WR250	74-12	18x22x21.8	N1
	N1021	CR/WR300	08-12	18x22x21.8	N1
	N1049	CR/WR360	all	18x22x23,5	N1
KAWASAKI	N1036	KDX50	03-06	12x16x15.8	N1
	N1036	KFX50	03-08	12x16x15.8	N1
	N1036	KX60	83-03	12x16x15.8	N1
	N1036	KX65	00-13	12x16x15.8	N1
	N1007	KX80	79-00	14x18x17.2	N1
	N1036	KFX80	03-06	12x16x15.8	N1
	N1007	KX85	01-13	14x18x17.2	N1
	N1007	KX100	95-13	14x18x17.2	N1
	N1003	KX125	78-81	16x20x19.8	N1
	N1016	KX125	82-93	16x21x19.5	N1
	N1016	KX125	81-93	16x21x19.5	N1
	N1047	KX125	94-97	15x19x17.3	N1
	N1010	KX125	94-08	15x19x19.5	N1
	N1003	KDX125	80	16x20x19.8	N1
	N1016	KMX125	all	16x21x19.5	N1
	N1003	KX 175	80-81	16x20x19.8	N1
	N1016	KDX200	86-09	16x21x19.5	N1



## Nadellager • Needle Bearings



	PART No	Fits Modell	Year	Dimension	Price code
KAWASAKI	N1016	KDX220	97-04	16x21x19.5	N1
	N1049	KX250	78-07	18x22x23.5	N1
	N1049	KDX250	80-84	18x22x23.5	N1
	N1052	KX500	88-04	19x24x24.8	N1
	N1014	500H1 Mach III		16x20x22.5	N1
	N1017	750MachIV 750 H2	73-75	16x21x22.5	N1
KTM	N1001	SX50	01-08	12x15x14.5	N1
	N1001	SX50	09-13	12x15x14.5	N1
	N1037	SX60	97-99	12x15x16.3	N1
	N1037	SX65	99-13	12x15x16.3	N1
	N1037	Mini Adventurer	02-06	12x15x16.3	N1
	N1006	SX85	03-13	14x18x16.5	N1
	N1006	SX105	10-13	14x18x16.5	N1
	N1010	SX125	87-93	15x19x19.5	N1
	N1010	SX125	98-13	15x19x19.5	N1
	N1010	SX144	07-08	15x19x19.5	N1
	N1010	SX150	09-11	15x19x19.5	N1
	N1013	SX200	98-13	16x20x19.5	N1
	N1020	SX/EXC250	90-99	18x22x19.8	N1
	N1020	SX/EXC250	00-13	18x22x19.8	N1
	N1020	SX/EXC300	90-09	18x22x19.8	N1
	N1020	SX/EXC360	96-97	18x22x19.8	N1
	N1020	SX/EXC380	98-02	18x22x19.8	N1
	N1052	KX500	88-04	19x24x24.8	N1
POLARIS	N1022	Polaris Trail Boss & Scrambler & Trail Blazer 250	all	18x23x21.8	N1
	N1022	ATV300	94-00	18x23x21.8	N1
	N1028	Liberty Motor 700	-	20x25x22.8	N1
SUZUKI	N1002	RM60	03	12x16x14.8	N1
	N1002	RM65	03-06	12x16x14.8	N1
	N1036	RM80	77-81	12x16x15.8	N1
	N1006	RM80	93-12	14x18x16.5	N1

## Nadellager • Needle Bearings



	PART No	Fits Modell	Year	Dimension	Price code
SUZUKI	N1006	RM85	02-13	14x18x16.5	N1
	N1008	RM100	76	14x18x19.8	N1
	N1008	RM100	79-81	14x18x19.8	N1
	N1008	RM100	03-04	14x18x19.8	N1
	N1008	RM125	77-87	14x18x19.8	N1
	N1010	RM125	88-11	15x19x19.5	N1
	N1016	PE175	80-84	16x21x19.5	N1
	N1022	RM250	77-11	18x23x21.8	N1
	N1022	RMX250	89-98	18x23x21.8	N1
TM	N1010	TM125	all	15x19x19.5	N1
YAMAHA	N1005	PW50	92-04	10x14x12.5	N1
	N1037	DT50	all	12x15x16.3	
	N1037	PW80/BW80	83-04	12x15x16.3	
	N1002	KZ80	81	12x16x14.8	N1
	N1037	YZ80	74-80	12x15x16.3	N1
	N1002	YZ80	81	12x16x14.8	N1
	N1004	YZ80	82-92	12x17x14.2	N1
	N1006	YZ80	93-01	14x18x16.5	N1
	N1006	YZ85	02-14	14x18x16.5	N1
	N1006	YZ100	77-81	14x18x16.5	N1
	N1013	DT125	73 up	16x20x19.5	N1
	N1016	DTR125 & E	88-96	16x21x19.5	N1
	N1013	YZ125	77-96	16x20x19.5	N1
	N1011	YZ125	97-00	15x20x17.8	N1
	N1047	YZ125	01-14	15x19x17.3	N1
	N1015	Yam. DT-R125 all	all	16x21x17.5	N1
	N1016	Yam.TDR125 all	all	16x21x19.5	N1
	N1016	Yam.TZR125		16x21x19.5	N1
	N1014	YZ175	77-81	16x20x22.5	N1
	N1014	IT175	77-81	16x20x22.5	N1
N1017	IT200	84-86	16x21x22.5	N1	

## Nadellager • Needle Bearings



	PART No	Fits Modell	Year	Dimension	Price code
YAMAHA	N1021	IT250	76-82	18x22x21.8	N1
	N1022	IT250	83	18x23x21.8	N1
	N1021	YZ250	76-82	18x22x21.8	N1
	N1022	YZ250	83-96	18x23x21.8	N1
	N1022	WR250	88-98	18x23x21.8	N1
	N1021	DT250	74-79	18x22x21.8	N1
	N1021	MX250	73-75	18x22x21.8	N1
	N1022	YZ250	88-98	18x23x21.8	N1
	N1021	YZ250	99-14	18x22x21.8	N1
	N1022	WR250	83-98	18x23x21.8	N1
	N1014	RD350	73-75	16x20x22.5	N1
	N1017	RD350	all	16x21x22.5	N1
	N1014	RD400	76-79	16x20x22.5	N1
	N1017	YFS200 Blaster	through to 06	16x21x22.5	N1
	N1017	YZF 350 Banshee	through to 06	16x21x22.5	N1
	N1021	YZ400	77-79	18x22x21.8	N1
	N1021	IT400	77-78	18x22x21.8	N1
	N1021	IT425	80	18x22x21.8	N1
	N1022	YZ465	80-81	18x23x21.8	N1
	N1022	IT465	80-82	18x23x21.8	N1
	N1022	IT490	82-84	18x23x21.8	N1
	N1022	YZ490	82-90	18x23x21.8	N1
	N1022	WR500	91-95	18x23x21.8	N1

## Nadellager • Needle Bearings



IN x EX x lenght dimensions	PART No	Price code
10x14x12,5	N1005	N1
12x15x14,5	N1001	N1
12x15x16,3	N1037	N1
12x16x14,8	N1002	N1
12x16x15,8	N1036	N1
12x17x14,2	N1004	N1
14x18x16,5	N1006	N1
14x18x17,2	N1007	N1
14x18x19,8	N1008	N1
15x19x16,8	N1009	N1
15x19x17,3	N1047	N1
15x19x19,5	N1010	N1
15x20x17,8	N1011	N1
16x20x17,3	N1012	N1
16x20x19,5	N1013	N1
16x20x19,8	N1003	N1
16x20x22,5	N1014	N1
16x21x17,5	N1015	N1
16x21x19,5	N1016	N1
16x21x22,5	N1017	N1
18x22x19,8	N1020	N1

IN x EX x lenght dimensions	PART No	Price code
18x22x21,8	N1021	N1
18x22x22,8	N1048	N1
18x22x23,5	N1049	N1
18x23x21,8	N1022	N1
18x23x23,8	N1024	N1
19x24x24,8	N1052	N1
20x24x22,5	N1025	N1
20x25x21,8	N1027	N1
20x25x22,8	N1028	N1
20x25x24,8	N1029	N1
20x25x27,8	N1030	N1
20x26x23,8	N1031	N1
21x25x23,8	N1032	N1
22x27x22,8	N1033	N1
22x27x24,8	N1034	N1
22x28x15,6	N1050	N1
24x29x24,8	N1075	N1
24x30x15,8	N1051	N1
24x30x16,8	N1053	N1
30x40x22,8	N4002	-
40x50x22,8	N4001	-

## Kurbelwellenlager • Main Bearings



tba = to be announced

	PART No	Fits Modell	Year	Pieces	Dimension	Price code
GasGas	MB6322C4	MC125	00-11	2	22x56x16	M12
	MB6322C4	EC125	00-11	2	22x56x16	M12
HONDA	MB6304C3	XR50R	00-03	2	20x52x15	M5
	MB6304C3	CRF50	04-09	2	20x52x15	M5
	MB6304C3	XR70R	00-03	2	20x52x15	M5
	MB6304C3	Honda CRF70 '97-08	97-08	2	20x52x15	M5
	MB6322C4	CR80	86-91	2	22x56x16	M12
	MB6322C4	CR85	03-07	2	22x56x16	M12
	MB6304C3	CR125	79	2	20x52x15	M5
	MB6322C4	CR125	80-07	2	22x56x16	M12
	MB6328C3	CR250R	78-96	2	28x68x18	M17
	MB6328C3	ATAC250	84-85	2	28x68x18	M17
	MB6328C3	CR250R	97-99	2	28x68x18	M17
	MB6328C4	CR250R	00-07	2	28x68x18	M17
	MB6328C3	ATC250R	87-90	2	28x68x18	M17
	MB6328C3	CRF250	04-13	2	28x68x18	M17
	MB6328C3	CRF250X	04-09	2	28x68x18	M17
	MB6328C3	CRF450R	02-13	2	28x68x18	M17
	MB6328C3	CRF450R Big Bore	02-08	2	28x68x18	M17
	MB6328C4	CR500	84-89	2	28x68x18	M17
	MB6307C3	XLR500	79-84	2	35x80x21	M21
	MB6307C3	XLS500	79-84	2	35x80x21	M21
	MB6307C3	XR500R	79-82	2	35x80x21	M21
	MB6308C3	NX650 Dominator	88-01	2	40x62x12	M23
	MB6308C3	XR650C	93-12	2	40x62x12	M23
MB6308C3	XR650L	96-07	2	40x62x12	M23	
MB6308C3	XR650R	00-07	2	40x62x12	M23	
HUSABERG	MBNJ206C3	FC450	09-12	2	30x62x16	tba
	MBNJ206C3	FE450	09-12	2	30x62x16	tba
	MBNJ206C3	FX450	10-12	2	30x62x16	tba
HUSQVARNA	MB6322C4	CR125	97-13	2	22x56x16	M12
	MB6322C4	WR125	97-13	2	22x56x16	M12
	MB6322C4	SM125	97-13	2	22x56x16	M12
	MB6322C4	SMS125	97-13	2	22x56x16	M12

## Kurbelwellenlager • Main Bearings



tba = to be announced

	PART No	Fits Modell	Year	Pieces	Dimension	Price code
HUSQVARNA	MB6322C4	WRE125	97-13	2	22x56x16	M12
	MB6322C4	CR150	11	2	22x56x16	M12
	MB6305C3	CR250	98-05	2	25x62x17	M10
	MB6305C3	WR250	98-13	2	25x62x17	M10
	MB6305C3	WR300	09-13	2	25x62x17	M10
KAWASAKI	MB6304C3	KX60	83-03	2	20x52x15	M5
	MB6304C3	KX65	00-13	2	20x52x15	M5
	MB6304C3	KX80	82-85	2	20x52x15	M5
	MB6304C3	KX80 U.S. Bore	88-00	2	20x52x15	M5
	MB6304C3	KX80 Int. Bore	88-00	2	20x52x15	M5
	MB6204C3	KFX80	03-06	2	20x47x14	M6
	MB6304C3	KX85	01-13	2	20x52x15	M5
	MB6304C3	KX100	95-13	2	20x52x15	M5
	MB6304C3	KX125	78-81	2	20x52x15	M5
	MB6304C3	KX125	82-84	Right 1x	20x52x15	M5
	MB6322C3	KX125	85-87	Right 1x	25x56x16	M12
	MB6305C3	KX125	82-87	Left 1x	25x62x17	M10
	MB6322C4	KX125	88-08	2	25x56x16	M12
	MB6305JR2	KDX220R	98-05	2	25x62x16	tba
	MB6305C3	KDX250	80-82	2	25x62x17	M10
	MB6305C3	KX250	78-86	2	25x62x17	M10
	MB6328C3	KX250	87-01	2	28x68x18	M17
	MB6328C3	KDX250	90-94	2	28x68x18	M17
	MB6328C4	KX250	02-08	2	28x68x18	M17
	MB6206RSI	KX250F	04-13	2	30x62x16	M19
	MB6306C3	KX500	88-04	2	30x72x19	M16
KTM	MB6203C3	SX50	01-13	2	17x40x21	M1
	MB6304C3	SX60	97-99	2	20x52x15	M5
	MB6304C3	SX65	00-13	2	20x52x15	M5
	MB6304C3	SX85	03-13	2	20x52x15	M5
	MB6304C3	SX105	03-08	2	20x52x15	M5
	MB63052RS	EXC125	01-13	Right 1x	25x62x17	M15
	MB63052RS	SX125	01-13	Right 1x	25x62x17	M15
	MB63052RS	SX150	09-12	Right 1x	25x62x17	M15
	MB63052RS	EXC200	98-13	Right 1x	25x62x17	M15
	MBNJ206	EXC125	01-13	Left 1x	30x62x16	M29

## Kurbelwellenlager • Main Bearings



tba = to be announced

	PART No	Fits Modell	Year	Pieces	Dimension	Price code
KTM	MBNJ206	SX125	01-13	Left 1x	30x62x16	M29
	MBNJ206	SX150	09-12	Left 1x	30x62x16	M29
	MBNJ206	EXC200	98-13	Left 1x	30x62x16	M29
	MBNJ206	SX-EX520	00-02	2	30x62x16	M29
	MBNJ206	SX-EX525	03-07	2	30x62x16	M29
	MBNJ206	SMR650	06-07	2	30x62x16	M29
	MBNJ206C3	MXC250	00-05	2	30x62x16	-
	MBNJ206C3	EXC250	00-05	2	30x62x16	-
	MBNJ206C3	SX250	03-13	2	30x62x16	-
	MBNJ206C3	EXC250	06-13	2	30x62x16	-
	MBNJ206C3	SX-F250	06-12	2	30x62x16	-
	MBNJ206C3	EXC450	03-07	2	30x62x16	-
	MBNJ207RC3	400LC4	97-12	Left 1x	35x73x17	M32
	MBNJ306C3	400LC4	98-01	Right 1x	30x72x19	M28
SUZUKI	MB6204C3	RM80	89-90	Left 1x	20x47x14	M6
	MB6304C3	RM80	89-90	Right 1x	20x52x15	M5
	MB6304C3	RM80 Int. Bore	91-01	2	20x52x15	M5
	MB6304C3	RM80 US Bore	91-01	2	20x52x15	M5
	MB6304C3	RM85	02-13	2	20x52x15	M5
	MB6304C3	RM100	03	2	20x52x15	M5
	MB6205C3	RM125	81-88	Left 1x	25x52x15	M7
	MB6322C3	RM125	81-88	Right 1x	25x56x16	M12
	MB6322C4	RM125	89-11	2	25x56x16	M12
	MB6206C3	RM250	82-88	Left 1x	30x62x16	M4
	MB6305C3	RM250	82-93	Right 1x	25x62x17	M10
	MB6305C3	RMX250	89-93	2	25x62x17	M10
	MB6328C3	RM250	94-04	2	28x68x18	M17
	MB6328C3	RXM250	94-04	2	28x68x18	M17
	MB6206RSI	RM-Z250	04-06	2	30x62x16	M19
	MB830046-14	RM-Z250	07-09	2	30x62x16	M30
	MB830046-20	RM-Z250	10-13	2	30x63x16	M27
	MB83C072C	RM-Z450	05-07	2	30x72x19	M24
	MB83C072C	RM-Z450	08-13	Right 1x	30x72x19	M24
	MB830053-4	RM-Z450	08-13	Left 1x	32x75x20	M31
	MB6232C3	LT250	88-92	Left 1x	32x65x17	M20
	MB6206C3	LT250	88-92	Right 1x	30x62x16	M4

## Kurbelwellenlager • Main Bearings



tba = to be announced

	PART No	Fits Modell	Year	Pieces	Dimension	Price code
YAMAHA	MB6203C3	PW50	81-12	2	17x40x12	M1
	MB6205C3	PW80	thru 2006	2	25x52x15	M7
	MB6205C3	BW80	86-88 & 90	2	25x52x15	M7
	MB6204C3	YZ80	82-92	2	20x47x14	M6
	MB6204C3	YZ80 U.S. Bore	93-01	Left 1x	20x47x14	M6
	MB6304C3	YZ80 U.S. Bore	93-01	Right 1x	20x52x15	M5
	MB6204C3	YZ80 Int. Bore	93-01	Left 1x	20x52x15	M6
	MB6304C3	YZ80 Int. Bore	93-01	Right 1x	20x52x15	M5
	MB6204C3	YZ85	02-13	Left 1x	20x52x15	M6
	MB6304C3	YZ85	02-13	Right 1x	20x52x15	M5
	MB6205C3	YZ125	76-82	Left 1x	25x52x15	M7
	MB6304C3	YZ125	76-82	Right 1x	20x52x15	M5
	MB6205C3	YZ125	84-85	Left 1x	25x52x15	M7
	MB6304C3	YZ125	84-85	Right 1x	20x52x15	M5
	MB6322C4	YZ125	86-13	2	22x56x16	M12
	MB6206C3	YZ250	83-87	2	30x62x16	M4
	MB6328C3	YZ250	88-13	2	28x68x18	M17
	MB6328C3	WR250	88-99	2	28x68x18	M17
	MB83A915	YFS200 Blaster	88-06	Left	25x55x15	M18
	MB830046-1	YZ250F	01-13	2	30x64x16	M30
	MB830046-1	WR250F	01-13	2	30x64x16	M30
	MB83C072C	YZ400F	98-99	2	30x72x19	M24
	MB83C072C	WR400F	98-99	2	30x72x19	M24
	MB83C072C	YZ426F	98-99	2	30x72x19	M24
	MB83C072C	WR426F	98-99	2	30x72x19	M24
	MB83C072C	YZ450F	03-09	2	30x72x19	M24
	MB83C072C	WR450F	03-09	2	30x72x19	M24
	MB83C072C	YFZ450	04-13	2	30x72x19	M24



## Kurbelwellenlager • Main Bearings



PART No	Dimension	Price code
MB6201C3	12x32x10	M2
MB6203C3	17x40x12	M1
MB6303C3	17x47x14	M8
MB6004C3	20x42x12	M9
MB6204C3	20x47x14	M6
MB6304C3	20x52x15	M5
MB6304/22	22x52x15	M11
MB6322C4	22x56x16	M12
MB6005C3	25x47x12	M3
MB6205C3	25x52x15	M7
MB6205C4	25x52x15	M7
MBNJ205	25x52x15	M25
MBNJ205C3	25x52x15	M26
MB83A915	25x55x15	M18
MB6322C3	25x56x16	M12
MB6305RI	25x62x16	M22
MB63052RS	25x62x17	M15
MB6305C3	25x62x17	M10
MB6228C3	28x58x16	M14

KOYO® nimmt den Rang als führender Hersteller von Lagern ein und konnte die ISO/TS 164949 Zertifizierung für die gesamte Lagerherstellung und den Verkaufsbereich erlangen. KOYO® hat sich bei den Autoherstellern und industriellen Herstellern weltweit durchgesetzt, bedingt durch ein ständig gleichbleibendes hohes Niveau an Produktqualität und Eigenschaften.

PART No	Dimension	Price code
MB6328C3	28x68x18	M17
MB6328C4	28x68x18	M17
MB16006C	30x55x9	M15
MB16006C3	30x55x9	M15
MB6206C3	30x62x16	M4
MB6206RSI	30x62x16	M19
MB830046-14	30x62x16	M30
MBNJ206	30x62x16	M29
MB830046-20	30x63x16	M27
MB830046-1	30x64x16	M30
MB6306C3	30x72x19	M16
MB83C072C	30x72x19	M24
MBNJ306C3	30x72x19	M28
MB6232C3	32x65x17	M20
MB830053-4	32x75x20	M31
MB6207C3	35x72x17	M13
MBNJ207RC3	35x72x17	M32
MB6307C3	35x80x21	M21
MB6308C3	40x62x12	M23

KOYO® Seiko (now JTEKT Corporation) rank as one of the world's leading manufacturer of bearings and automotiv steering systems. Through maintaining consistently high levels of product quality and performance, KOYO® has established itself with car manufacturers and industrial manufacturers around the world and has attained ISO/TS 16949 certification at all of our bearings manufacturer and sales facilities.

## Dichtungen • Top End Gaskets - 2 stroke



	PART No	Fits Modell	Year	Price code
APRILIA	D2091-EST	RS125, RX125	95-09	D4
GASGAS	D2042-EST	EC, MC, SM125	01-09	D20
	D2053-EST	EC, MC 250	97-11	D18
HONDA	D2001-EST	CR85	03-07	D17
	D2002-EST	CR125	90-97	D14
	D2003-EST	CR125	98-99	D14
	D2004-EST	CR125	00-02	D38
	D2005-EST	CR125	03	D38
	D2006-EST	CR125	04	D38
	D2007-EST	CR125	05-07	D44
	D2045-EST	NS125R	86-96	D5
	D2008-EST	CR250	92-01	D24
	D2009-EST	CR250	02-07	D44
	D2046-EST	CRM250	90-00	D46
HUSABERG	D2043-EST	TE125	12-13	D34
	D2044-EST	TE250	11-13	D28
	D2025-EST	TE250	11-13	D37
	D2025-EST	TE300	11-13	D37
HUSQVARNA	D2010-EST	CR125	97-09	D51
	D2044-EST	WR/CR 250	99-10	D43
	D2054-EST	CR/WR360	92-02	D15
KAWASAKI	D2011-EST	KX65	00-12	D28
	D2012-EST	KX80	98-00	D30
	D2012-EST	KX85	01-12	D30
	D2080-EST	KX100	98-12	D29
	D2048-EST	KX125	90-91	D40
	D2049-EST	KX125	98-99	D35
	D2071-EST	KX125	00-02	D45
	D2013-EST	KX125	03-08	D21
	D2047-EST	KMX125	91-93	D21
	D2014-EST	KX250	01-04	D20
	D2015-EST	KX250	05-08	D32
D2071-EST	KX125 L2-L3	00-02	D45	
KTM	D2085-EST	SX50	01-08	D1
	D2084-EST	SX50	09-13	D29
	D2019-EST	SX65	98-01	D19
	D2020-EST	SX65	02-08	D19
	D2016-EST	SX65	09-12	D55
	D2017-EST	SX 85	03-12	D1

	PART No	Fits Modell	Year	Price code
KTM	D2018-EST	EXC125, SX125	98-01	D39
	D2043-EST	EXC125, SX125	02-13	D34
	D2023-EST	EXC200	98-02	D56
	D2022-EST	SX200	03-12	D56
	D2024-EST	EXC250, SX250	04-06	D28
	D2025-EST	EXC250, SX250	07-13	D37
	D2077-EST	EGS/EXC/SX360	96-97	D33
	D2077-EST	EGS/EXC/SX380	98-02	D33
MAICO	D2064-EST	Maico250	78	D46
	D2065-EST	Maico250	81	D28
	D2067-EST	Maico250	83	D46
	D2092-EST	Maico250	84-87	D30
SUZUKI	D2011-EST	RM65	03-05	D28
	D2026-EST	RM85	02-13	D8
	D2080-EST	RM100	03-08	D29
	D2082-EST	RM125	90-91	D36
	D2073-EST	RM125	92-96	D22
	D2027-EST	RM125	97-12	D23
	D2050-EST	TS125	78-81	D8
	D2051-EST	TSR125	89-93	D17
	D2028-EST	RM250	89-90	D35
	D2029-EST	RM250	91-95	D24
	D2030-EST	RM250	96-98	D20
	D2031-EST	RM250	99-00	D27
	D2032-EST	RM250	01-02	D28
D2033-EST	RM250	03-08	D25	
YAMAHA	D2034-EST	YZ85	02-14	D3
	D2035-EST	DT125 56-58mm		D3
	D2036-EST	DT125 58.50-61mm		D3
	D2037-EST	YZ125	94-98	D12
	D2038-EST	YZ125	99-04	D12
	D2039-EST	YZ125	05-13	D12
	D2052-EST	DT200R	88-92	D30
	D2055-EST	YFS200 Blaster 68mm		D10
	D2040-EST	YZ250	88-96	D52
	D2041-EST	YZ250	99-14	D32
	D2068-EST	YFZ350 T/W/B/U/A 72mm	87-06	D61
	D2069-EST	YFZ350 T/W/B/U/A 66mm	87-06	D59
	D2070-EST	YFS200 D/F	88-06	D47

## Dichtungen • Top End Gaskets - 4 stroke



tba = to be announced

	PART No	Fits Modell	Year	Price code
HONDA	D4001-EST	CRF150R Pro Series	07-13	D65
	D4002-EST	CRF230	03-13	D67
	D4003-EST	XL/XR250 74mm	91-96	D77
	D4004-EST	CRF250	04-09	D78
	D4005-EST	CRF250	10-13	D71
	D4006-EST	CRF450	02-06	D87
	D4007-EST	CRF450	07-08	D87
	D4008-EST	CRF450	09-13	D87
	D4009-EST	TRX450 94mm	04-05	D91
	D4010-EST	TRX450 97mm	04-05	D91
	D4011-EST	TRX450	06-09	D91
	D4039-EST	XL, XR500	79-83	D83
	D4052-EST	NX650	88-89	D83
	HUSQVARNA	D4035-EST	TE/TC250	03-04
D4036-EST		TE/TC250	05-09	D112
D4037-EST		TE/TC450	03-09	D114
D4038-EST		TE/TC510	05-09	D121
D4012-EST		TE/TC610	92-01	D71
KAWASAKI	D4013-EST	KXF250	04-08	D87
	D4014-EST	KXF250	09-13	D87
	D4015-EST	KXF450	06-08	D89
	D4016-EST	KXF450	09-13	D76
	D4017-EST	KFX450	08-13	D87
	D4055-EST	KL600	84	D74
KTM	D4056-EST	KL600	85-86	D74
	D4018-EST	SXF250	06-13	D61
KTM	D4020-EST	SXF450	02-06	tba
	D4019-EST	SXF450	07-12	D101
	D4033-EST	EXC450R/530R	08-11	D96
	D4021-EST	SX, EXC520/525	00-07	D83
	D4034-EST	625/640 LC4 101mm	-	D98
	D4057-EST	SX-F350 complete set	-	D122
	D4061-EST	SX-F450	13	tba
	D4061-EST	EXC450	12-13	tba
	D4061-EST	EXC500	12-13	tba

	PART No	Fits Modell	Year	Price code
SUZUKI	D4022-EST	RMZ250	07-09	D73
	D4023-EST	DRZ/LTZ/KFX400	-	D120
	D4024-EST	RMZ450	05-06	D101
	D4025-EST	RMZ450	07	D101
	D4026-EST	RMZ450	08-13	D101
	D4027-EST	LTR450 96mm	06-09	D87
	D4028-EST	LTR450 100mm	06-09	D66
	D4044-EST	RM-Z250	10-13	D74
	YAMAHA	D4029-EST	YZF250	01-13
D4040-EST		YFM250 Raptor 74mm	-	D101
D4041-EST		YFM250 Raptor 76mm	-	D101
D4030-EST		YZF450	03-05	D101
D4031-EST		YZF450	06-09	D101
D4032-EST		YFZ450	04-09	D100
D4042-EST		YFM660R 100mm	-	D111
D4043-EST		YFM660R 102mm	-	D111
D4045-EST		YZ450F	10-13	D101
D4053-EST	XTZ660	91-98	D108	



We are the european distributor for Cometic - please contact us direct for all Cometic items.

## Ringe • Rings - 2 stroke



Alle Wössner Ringe können in Guss, sowie Nikasil® Zylindern eingesetzt werden.

All Woessner rings can be used in cast iron, Nikasil®, boron composite® and Electrofusion bores.

Caution:

Wössner 2-stroke rings can not be used in chrome plated bores

Ring Part No.	Fits Bore dia. (mm)	Ring height (mm)	Ring with (mm)	Price code
RxB3950	39,5	1	1,65	single ring 16 double ring 17
RxB4300	43	1	1,85	
RxB4350	43,5	1	1,85	
RxB4400	44	1	1,85	
RxB4450	44,5	1	1,85	
RxB4500	45	1	1,85	
RxB4550	45,5	1	1,85	
RxB4600	46	1	1,85	
RxB4650	46,5	1	1,85	
RxB4700	47	1	1,85	
RxB4750	47,5	1	1,85	
RxB4800	48	1	2,05	
RxB4850	48,5	1	2,1	
RxB4900	49	1	2,05	
RxB4950	49,5	1	2,05	
RxB5000	50	1	2,15	
RxB5050	50,5	1	2,15	
RxB5100	51	1	2,15	
RxB5150	51,5	1	2,15	
RxB5200	52	1	2,15	
RxB5250	52,5	1	2,15	
RxB5300	53	1	2,15	
RxB5350	53,5	1	2,15	
RxA5400	54	0,8	2,2	
RxB5400	54	1	2,2	
RxB5425	54,25	1	2,2	
RxB5450	54,5	1	2,3	
RxB5475	54,75	1	2,3	
RxB5500	55	1	2,3	
RxB5525	55,25	1	2,3	
RxB5550	55,5	1	2,3	
RxB5575	55,75	1	2,3	
RxB5600	56	1	2,3	
RxB5625	56,25	1	2,3	
RxB5650	56,5	1	2,3	
RxB5675	56,75	1	2,3	
RxB5700	57	1	2,3	
RxB5725	57,25	1	2,3	

Ring Part No.	Fits Bore dia. (mm)	Ring height (mm)	Ring with (mm)	Price code
RxB5750	57,5	1	2,3	single ring 16 double ring 17
RxB5775	57,75	1	2,3	
RxB5800	58	1	2,4	
RxB5850	58,5	1	2,4	
RxB5900	59	1	2,65	
RxB5950	59,5	1	2,65	
RxB6000	60	1	2,65	
RxB6050	60,5	1	2,65	
RxB6100	61	1	2,65	
RxB6150	61,5	1	2,65	
RxB6200	62	1	2,65	
RxB6250	62,5	1	2,65	
RxB6300	63	1	2,65	
RxB6350	63,5	1	2,65	
RxB6400	64	1	2,65	
RxB6425	64,25	1	2,65	
RxB6450	64,5	1	2,65	
RxB6475	64,75	1	2,65	
RxB6500	65	1	2,65	
RxB6525	65,25	1	2,65	
RxB6550	65,5	1	2,65	
RxB6600	66	1	2,65	
RxB6625	66,25	1	2,65	
RxB6640	66,4	1	2,65	
RxB6650	66,5	1	2,65	
RxB6675	66,75	1	2,65	
RxB6700	67	1	2,65	
RxB6725	67,25	1	2,65	
RxB6740	67,4	1	2,65	
RxB6750	67,5	1	2,65	
RxB6775	67,75	1	2,65	
RxB6800	68	1	2,8	
RxB6825	68,25	1	2,8	
RxB6850	68,5	1	2,8	
RxB6875	68,75	1	2,8	
RxB6900	69	1	2,8	
RxB6925	69,25	1	2,8	
RxB6950	69,5	1	2,8	

x = single or double ring S = single ring (e.g. RSB3950) D = double ring (e.g. RDB3950)

## Ringe • Rings - 2 stroke



Alle Wössner Ringe können in Guss, sowie Nikasil® Zylindern eingesetzt werden.

All Woessner rings can be used in cast iron, Nikasil®, boron composite® and Electrofusion bores.

Caution:

Wössner 2-stroke rings can not be used in chrome plated bores

Ring Part No.	Fits Bore dia. (mm)	Ring height (mm)	Ring with (mm)	Price code
RxB7000	70	1	2,8	single ring 16 double ring 17
RxB7025	70,25	1	2,8	
RxB7050	70,5	1	2,8	
RxB7075	70,75	1	2,8	
RxB7100	71	1	2,8	
RxB7125	71,25	1	2,8	
RxB7150	71,5	1	2,8	
RxB7200	72	1	3	
RxB7225	72,25	1	3	
RxB7250	72,5	1	3	
RxB7300	73	1	3	
RxB7350	73,5	1	3	
RxB7400	74	1	3	
RxB7450	74,5	1	3	
RxC7500	75	1,2	3,2	
RxC7550	75,5	1,2	3,2	
RxC7600	76	1,2	3,2	
RxC7650	76,5	1,2	3,2	
RxC7700	77	1,2	3,2	
RxC7750	77,5	1,2	3,2	
RxC7800	78	1,2	3,2	
RxC7850	78,5	1,2	3,2	
RxC7900	79	1,2	3,2	
RxD7900	79	1,5	3,15	

Ring Part No.	Fits Bore dia. (mm)	Ring height (mm)	Ring with (mm)	Price code
RxC8000	80	1,2	3,2	single ring 16 double ring 17
RxC8050	80,5	1,2	3,2	
RxC8100	81	1,2	3,2	
RxC8150	81,5	1,2	3,2	
RxC8200	82	1,2	3,2	
RxC8250	82,5	1,2	3,2	
RxC8300	83	1,2	3,2	
RxC8350	83,5	1,2	3,2	
RxC8400	84	1,2	3,2	
RxC8450	84,5	1,2	3,2	
RxC8500	85	1,2	3,2	
RxC8550	85,5	1,2	3,4	
RxC8600	86	1,2	3,2	
RxC8650	86,5	1,2	3,2	
RxC8700	87	1,2	3,4	
RxC8750	87,5	1,2	3,2	
RxC8800	88	1,2	3,6	
RxC8850	88,5	1,2	3,6	
RxC8900	89	1,2	3,6	
RxC8950	89,5	1,2	3,6	
RxC9000	90	1,2	3,6	
RxC9050	90,5	1,2	3,6	
RxC9100	91	1,2	3,6	
RxC10000	100	1,2	3,6	

x = single or double ring S = single ring (e.g. RSB3950) D = double ring (e.g. RDB3950)



## Ringe • Rings - 4 stroke



Alle Wössner Ringe können in Guss, sowie Nikasil® Zylindern eingesetzt werden.

All Woessner rings can be used in cast iron, Nikasil®, boron composite® and Electrofusion bores.

Ring Part No.	Fits Bore dia. (mm)	Top Ring (mm)	Second Ring (mm)	Oil Ring (mm)	Price code
530XKS	53	1	0,8	2	18
535XKS	53,5	1	0,8	2	18
540XKS	54	1	0,8	2	18
545XKS	54,5	1	0,8	2	18
550XKS	55	1	0,8	2	18
560XKS	56	1	0,8	2	18
565XKS	56,5	1	0,8	2	18
570XKS	57	1	0,8	2	18
575XKS	57,5	1	0,8	2	18
580XKS	58	1	0,8	2	18
585XKS	58,5	1	0,8	2	18
590XKS	59	1	0,8	2	18
595XKS	59,5	1	0,8	2	18
600XGS	60	1	1	2	18
600XKS	60	1	0,8	2	18
605XKS	60,5	1	0,8	2	18
605XDS	60,5	1	1,2	2	18
610XKS	61	1	0,8	2	18
615XKS	61,5	1	0,8	2	18
620XKS	62	1	0,8	2	18
625XKS	62,5	1	0,8	2	18
630XKS	63	1	0,8	2	18
635XKS	63,5	1	0,8	2	18
640XKS	64	1	0,8	2	18
645XKS	64,5	1	0,8	2	18
650XKS	65	1	0,8	2	18
650XDS	65	1	1,2	2	18
655XGS	65,5	1	1	2	18
660XKS	66	1	0,8	2	18
665XKS	66,5	1	0,8	2	18
670XKS	67	1	0,8	2	18
675XKS	67,5	1	0,8	2	18
680XKS	68	1	0,8	2	18
685XKS	68,5	1	0,8	2	18
690XKS	69	1	0,8	2	18
695XKS	69,5	1	0,8	2	18
700XDS	70	1	1,2	2	18
705XDS	70,5	1	1,2	2	18
710XDS	71	1	1,2	2	18

Ring Part No.	Fits Bore dia. (mm)	Top Ring (mm)	Second Ring (mm)	Oil Ring (mm)	Price code
715XDS	71,5	1	1,2	2	18
720XDS	72	1	1,2	2	18
725XDS	72,5	1	1,2	2	18
730XDS	73	1	1,2	2	18
730XAS	73	0,8	0,8	1,5	18
735XDS	73,5	1	1,2	2	18
740XDS	74	1	1,2	2	18
740XTZ	74	1,5	1,2	2	18
745XDS	74,5	1	1,2	2	18
745XTZ	74,5	1,5	1,2	2	18
750XDS	75	1	1,2	2	18
750XTZ	75	1,5	1,2	2	18
755XDS	75,5	1	1,2	2	18
755XTZ	75,5	1,5	1,2	2	18
760XDS	76	1	1,2	2	18
760XTZ	76	1,5	1,2	2	18
760XMS	76	0,8	0,8	2	18
760XAS	76	0,8	0,8	1,5	18
760XWY	76	1	0,8	1,5	18
765XDS	76,5	1	1,2	2	18
765XTZ	76,5	1,5	1,2	2	18
766XTZ	76,6	1,5	1,2	2	18
768XAS-2	76,8	0,8	-	1,5	18
770XKS	77	1	0,8	2	18
770XTT	77	1	1,2	3	18
770XDS	77	1	1,2	2	18
770XTZ	77	1,5	1,2	2	18
770XTD	77	1,5	1,2	3	18
770XAS-2	77	0,8	0,8	1,5	18
772XDS	77,25	1	1,2	2	18
775XDS	77,5	1	1,2	2	18
775XTZ	77,5	1,5	1,2	2	18
780XMS	78	0,8	0,8	2	18
780XDS	78	1	1,2	2	18
780XTT	78	1	1,2	3	18
780XTZ	78	1,5	1,2	2	18
780XAS	78	0,8	0,8	1,5	18
780XWY	78	1	0,8	1,5	18
785XDS	78,5	1	1,2	2	18

## Ring • Rings - 4 stroke



Alle Wössner Ringe können in Guss, sowie Nikasil® Zylindern eingesetzt werden.

All Woessner rings can be used in cast iron, Nikasil®, boron composite® and Electrofusion bores.

Ring Part No.	Fits Bore dia. (mm)	Top Ring (mm)	Second Ring (mm)	Oil Ring (mm)	Price code
785XTZ	78,5	1,5	1,2	2	18
787XDS	78,7	1	1,2	2	18
787XTZ	78,7	1,5	1,2	2	18
790XMS	79	0,8	0,8	2	18
790XDS	79	1	1,2	2	18
790XTZ	79	1,5	1,2	2	18
790XWY	79	1	0,8	?	18
795XDS	79,5	1	1,2	2	18
795XTZ	79,5	1,5	1,2	2	18
797XDS	79,75	1	1,2	2	18
800XTT	80	1	1,2	3	19
800XDS	80	1	1,2	2	19
800XTZ	80	1,5	1,2	2	19
802XDS	80,25	1	1,2	2	19
805XDS	80,5	1	1,2	2	19
805XTZ	80,5	1,5	1,2	2	19
810XDS	81	1	1,2	2	19
810XSY	81	1	1,2	2,5	19
810XTY	81	1,5	1,2	2,5	19
815XSY	81,5	1	1,2	2,5	19
815XTY	81,5	1,5	1,2	2,5	19
820XSY	82	1	1,2	2,5	19
820XDS	82	1	1,2	2	19
820XTY	82	1,5	1,2	2,5	19
825XSY	82,5	1	1,2	2,5	19
825XTY	82,5	1,5	1,2	2,5	19
827XDS	82,7	1	1,2	2	19
827XSY	82,7	1	1,2	2,5	19
827XTY	82,7	1,5	1,2	2,5	19
830XSY	83	1	1,2	2,5	19
830XTY	83	1,5	1,2	2,5	19
830XDS	83	1	1,2	2	19
835XSY	83,5	1	1,2	2,5	19
835XTY	83,5	1,5	1,2	2,5	19
840XSY	84	1	1,2	2,5	19
840XTY	84	1,5	1,2	2,5	19
840XDS	84	1	1,2	2	19
842XSY	84,2	1	1,2	2,5	19
842XTY	84,2	1,5	1,2	2,5	19

Ring Part No.	Fits Bore dia. (mm)	Top Ring (mm)	Second Ring (mm)	Oil Ring (mm)	Price code
844XSY	84,4	1	1,2	2,5	19
844XTY	84,4	1,5	1,2	2,5	19
845XSY	84,5	1	1,2	2,5	19
845XTY	84,5	1,5	1,2	2,5	19
846XSY	84,6	1	1,2	2,5	19
846XTY	84,6	1,5	1,2	2,5	19
847XSY	84,75	1	1,2	2,5	19
848XSY	84,8	1	1,2	2,5	19
848XTY	84,8	1,5	1,2	2,5	19
850XSY	85	1	1,2	2,5	19
850XTY	85	1,5	1,2	2,5	19
855XSY	85,5	1	1,2	2,5	19
855XTY	85,5	1,5	1,2	2,5	19
860XDS	86	1	1,2	2	19
860XSY	86	1	1,2	2,5	19
860XTY	86	1,5	1,2	2,5	19
862XSY	86,25	1	1,2	2,5	19
862XTY	86,25	1,5	1,2	2,5	19
865XSY	86,5	1	1,2	2,5	19
865XTY	86,5	1,5	1,2	2,5	19
867XSY	86,75	1	1,2	2,5	19
867XTY	86,75	1,5	1,2	2,5	19
870XSY	87	1	1,2	2,5	19
870XTY	87	1,5	1,2	2,5	19
875XSY	87,5	1	1,2	2,5	19
875XTY	87,5	1,5	1,2	2,5	19
880XSY	88	1	1,2	2,5	19
880XTY	88	1,5	1,2	2,5	19
880XDS	88	1	1,2	2	19
885XSY	88,5	1	1,2	2,5	19
885XTY	88,5	1,5	1,2	2,5	19
890XSY	89	1	1,2	2,5	19
890XTY	89	1,5	1,2	2,5	19
892XSY	89,25	1	1,2	2,5	19
895XSY	89,5	1	1,2	2,5	19
897XSY	89,75	1	1,2	2,5	19
895XTY	89,5	1,5	1,2	2,5	19
900XDS	90	1	1,2	2	19
900XSY	90	1	1,2	2,5	19

## Ring • Rings - 4 stroke



Alle Wössner Ringe können in Guss, sowie Nikasil® Zylindern eingesetzt werden.

All Woessner rings can be used in cast iron, Nikasil®, boron composite® and Electrofusion bores.

Ring Part No.	Fits Bore dia. (mm)	Top Ring (mm)	Second Ring (mm)	Oil Ring (mm)	Price code
900XTY	90	1,5	1,2	2,5	19
905XSX	90,5	1	1,2	2,5	19
905XTY	90,5	1,5	1,2	2,5	19
910XSX	91	1	1,2	2,5	19
910XTY	91	1,5	1,2	2,5	19
912XSX	91,25	1	1,2	2,5	19
912XTY	91,25	1,5	1,2	2,5	19
915XSX	91,5	1	1,2	2,5	19
915XTY	91,5	1,5	1,2	2,5	19
917XSX	91,75	1	1,2	2,5	19
917XTY	91,75	1,5	1,2	2,5	19
920XDS	92	1	1,2	2	19
920XSX	92	1	1,2	2,5	19
920XTY	92	1,5	1,2	2,5	19
925XSX	92,5	1	1,2	2,5	19
925XTY	92,5	1,5	1,2	2,5	19
930XSX	93	1	1,2	2,5	19
930XTY	93	1,5	1,2	2,5	19
935XSX	93,5	1	1,2	2,5	19
935XTY	93,5	1,5	1,2	2,5	19
936XSX	93,6	1	1,2	2,5	19
938XSX	93,8	1	1,2	2,5	19
938XTY	93,8	1,5	1,2	2,5	19
940XSX	94	1	1,2	2,5	19
940XTY	94	1,5	1,2	2,5	19
942XSX	94,2	1	1,2	2,5	19
942XTY	94,2	1,5	1,2	2,5	19
945XSX	94,5	1	1,2	2,5	19
945XTY	94,5	1,5	1,2	2,5	19
950XDS	95	1	1,2	2	19
950XSX	95	1	1,2	2,5	19
950ADS-2	95	1	-	2	19
950XTY	95	1,5	1,2	2,5	19
955XSX	95,5	1	1,2	2,5	19
955XTY	95,5	1,5	1,2	2,5	19
960XSX	96	1	1,2	2,5	19
960ADS-2	96	1	-	2	19
960XTY	96	1,5	1,2	2,5	19
965XTY	96,5	1,5	1,2	2,5	19

Ring Part No.	Fits Bore dia. (mm)	Top Ring (mm)	Second Ring (mm)	Oil Ring (mm)	Price code
965XSX	96,5	1	1,2	2,5	19
970XTY	97	1,5	1,2	2,5	19
970XSX	97	1	1,2	2,5	19
970ADS-2	97	1	-	2	19
970XDS	97	1	1,2	2	19
975XSX	97,5	1	1,2	2,5	19
975XTY	97,5	1,5	1,2	2,5	19
980XSX	98	1	1,2	2,5	19
980ADS-2	98	1	-	2	19
980XDS	98	1	1,2	2	19
980XTY	98	1,5	1,2	2,5	19
985XSX	98,5	1	1,2	2,5	19
985XTY	98,5	1,5	1,2	2,5	19
987XSX	98,75	1	1,2	2,5	19
990XSX	99	1	1,2	2,5	19
990XTY	99	1,5	1,2	2,5	19
992XSX	99,2	1	1,2	2,5	19
995XSX	99,5	1	1,2	2,5	19
995XTY	99,5	1,5	1,2	2,5	19
1000ADS-2	100	1	-	2	20
1000XSX	100	1	1,2	2,5	20
1000XTY	100	1,5	1,2	2,5	20
1005XSX	100,5	1	1,2	2,5	20
1005XTY	100,5	1,5	1,2	2,5	20
1010XSX	101	1	1,2	2,5	20
1010XTY	101	1,5	1,2	2,5	20
1015XSX	101,5	1	1,2	2,5	20
1016XSU	101,6	1,2	1,5	2,5	20
1020XSK	102	1,2	1,5	2,5	20
1020XSU	102	1,2	1,5	2,5	20
1025XSU	102,5	1,2	1,5	2,5	20
1030XSU	103	1,2	1,5	2,5	20
1035XSU	103,5	1,2	1,5	2,5	20
1040XSU	104	1,2	1,5	2,5	20
1045XSU	104,5	1,2	1,5	2,5	20
1050XSU	105	1,2	1,5	2,5	20
1055XSU	105,5	1,2	1,5	2,5	20
1060XSU	106	1,2	1,5	2,5	20
1065XSU	106,5	1,2	1,5	2,5	20



## Bolzen • Pins



T=conical shape  
 C=chromium plated for plain bearing only  
 S= cylindrical shape  
 R= radius  
 $\varnothing D$  =  $\varnothing$  outside  
 $\varnothing d$  =  $\varnothing$  inside

$\varnothing$	Part No.	Dimension $\varnothing D \times \varnothing d \times l$	Typ	Weight in gramm	Price code
$\varnothing 10$	WP105	10x7x33	S	10gr	13
$\varnothing 12$	WP091	12x8x37.5	S	18gr	13
	WP101	12x8x33	S	16gr	13
$\varnothing 13$	WP088	13x8x40	CT	24gr	13
$\varnothing 14$	WP058	14x10x38.5	T	21gr	13
	WP025	14x9.0x45	S	31gr	13
	WP063	14x8x38,5	CT	28gr	13
$\varnothing 15$	WP032	15x10x45	T	33gr	13
	WP011	15x9.0x45	S	39gr	13
	WP067	15x10x41	T	29gr	13
	WP102	15x10x54	CS	41gr	13
$\varnothing 16$	WP087	16x10x36	CT	33gr	13
	WP036	16x10x45	T	41gr	13
	WP041	16x10.5x51	T	42gr	13
	WP059	16x9.0x45	CT	44gr	13
	WP027	16x11x56.2	T	44gr	13
	WP066	16x9x42	CS	45gr	13
	WP070	16x9x38	CS	41gr	13
$\varnothing 17$	WP083	17x10x46	CT	49gr	13
	WP090	17x10x51	CT	55gr	13
	WP089	17x10x58	CT	63gr	13
	WP045	17x11x61	CS	63gr	13
$\varnothing 17,463$	WP062	11/16"x11x51	CT	51gr	13

$\varnothing$	Part No.	Dimension $\varnothing D \times \varnothing d \times l$	Typ	Weight in gramm	Price code
$\varnothing 18$	WP054	18x11x45	CT	54gr	13
	WP049	18x12x45	CT	45gr	13
	WP072	18x8x46	CT	70gr	13
	WP099	18x10x51	CT	68gr	13
	WP053	18x9.0x51	CT	71gr	13
	WP031	18x11x51	CT	60gr	13
	WP039	18x12x56	T	59gr	13
	WP042	18x11x62.8	T	71gr	13
	WP040	18x13x53.2	T	47gr	13
	WP033	18x13x56.2	T	49gr	13
	WP064	18x10x56	CS	76gr	13
	WP079	18x12x62,8	S	74gr	13
	$\varnothing 18.5$	WP084	18.5x11x55.5	CT	71gr
$\varnothing 19$	WP037	19x10x51	T	75gr	13
	WP071	19x9.2x46	T	74gr	13
	WP028	19x12x46	CT	56gr	13
	WP018	19x12x48	CT	58gr	13
	WP050	19x12x51	CT	61gr	13
	WP026	19x12x55.5	CT	68gr	13
	WP044	19x13x56.4	T	62gr	13
WP019	19x13x61	S	73gr	13	
$\varnothing 19,05$	WP048	3/4"x12x56	CT	68gr	13
$\varnothing 19.46$	WP096	19.46x12x51	CT	66gr	13
	WP035	19.46x12x61	CT	80gr	13

## Bolzen • Pins



T=conical shape  
 C=chromium plated for plain bearing only  
 S= cylindrical shape  
 R= radius  
 $\varnothing D = \varnothing$  outside  
 $\varnothing d = \varnothing$  inside

$\varnothing$	Part No.	Dimension $\varnothing D \times \varnothing d \times l$	Typ	Weight in gramm	Price code
Ø20	WP052	20x12,5x55	CT	79gr	14
	WP029	20x13x46	CT	58gr	14
	WP038	20x13x51	T	66gr	14
	WP061	20x11x61	CS	105gr	14
	WP086	20x13x61	T	79gr	14
	WP065	20x11x55	CS	93gr	14
	WP068	20x12x51	CR	75gr	14
	WP073	20x10x46	CT	81gr	14
	WP075	20x12,5x49	CT	72gr	14
	WP076	20x14x56	T	63gr	14
Ø20.12	WP020	0,792"x12x51	CT	73gr	14
	WP021	0,792"x12x56	CT	82gr	14
	WP093	0,792"x13x72	CS	104gr	14
Ø20.63	WP195	13/16"x13x55.5	CT	79gr	14
	WP095	20,625x13x55.5	CT	79gr	14
	WP174	13/16"x12,5x49	CT	76gr	14
	WP074	20,625x12,5x49	CT	76gr	14
Ø21	WP013	21x13.5x46	CT	73gr	14
	WP051	21x13.5x51	CT	75gr	14
	WP034	21x13x55.5	CT	86gr	14
	WP092	21x12x61	CS	111gr	14
	WP081	21x14x61	T	82gr	14

$\varnothing$	Part No.	Dimension $\varnothing D \times \varnothing d \times l$	Typ	Weight in gramm	Price code
Ø22	WP097	22x12x46	CS	96gr	14
	WP055	22x14x46	CT	69gr	14
	WP009	22x14x51	CT	76gr	14
	WP098	22x13x51	CS	99gr	14
	WP017	22x14x55	CT	87gr	14
	WP046	22x14x63	CT	98gr	14
	WP080	22x15x61	T	87gr	14
	WP077	22x16x63	T	83gr	14
	WP069	22x14x63	C	104gr	14
	Ø22.22	WP085	7/8"x14x63	CT	105gr
Ø23	WP008	23x13x50.5	CT	98gr	14
	WP047	23x13x50.5	CS	112gr	14
	WP024	23x15x55.5	CT	95gr	14
	WP094	23x13x61	CT	126gr	14
	WP082	23x13x55,5	CS	123gr	14
Ø23,55	WP056	0,927"x15.9x56	CT	96gr	14
	WP060	0,927"x15.9x51	CT	86gr	14
	WP100	0,927"x15.7x2,25"	CS	108gr	14
Ø23,813	WP103	0,927"x14x2,75"	CS	154gr	14
	WP043	15/16"x15x63	CT	124gr	14
Ø24	WP023	24x16x51	CT	92gr	14
	WP057	24x17x56	CT	90gr	14
	WP022	24x16x63.5	CT	121gr	14
	WP078	24x17x68	T	113gr	14
Ø26	WP104	26x16x63	C	161gr	13

## Bolzen • Pins



T=conical shape  
C=chromium plated for plain bearing only  
S= cylindrical shape  
R= radius  
ØD = Ø outside  
Ød = Ø inside

Ø	Part No.	Dimension ØDxØdxl	Typ	Weight in gramm	Price code
Ø23	WP008	23x13x50.5	CT	98gr	14
	WP047	23x13x50.5	CS	112gr	14
	WP024	23x15x55.5	CT	95gr	14
	WP094	23x13x61	CT	126gr	14
	WP082	23x13x55,5	CS	123gr	14
	Ø24	WP023	24x16x51	CT	92gr
WP057		24x17x56	CT	90gr	14
WP022		24x16x63.5	CT	121gr	14
WP078		24x17x68	T	113gr	14
Ø26	WP104	26x16x63	C	161gr	13
Ø17,463	WP062	11/16"x11x51	CT	51gr	13
Ø19,05	WP048	3/4"x12x56	CT	68gr	13

Ø	Part No.	Dimension ØDxØdxl	Typ	Weight in gramm	Price code
Ø20.12	WP020	0,792"x12x51	CT	73gr	14
	WP021	0,792"x12x56	CT	82gr	14
	WP093	0,792"x13x72	CS	104gr	14
Ø20.63	WP195	13/16"x13x55.5	CT	79gr	14
	WP095	20,625x13x55.5	CT	79gr	14
	WP174	13/16"x12,5x49	CT	76gr	14
	WP074	20,625x12,5x49	CT	76gr	14
	Ø22.22	WP085	7/8"x14x63	CT	105gr
Ø23,55	WP056	0,927"x15.9x56	CT	96gr	14
	WP060	0,927"x15.9x51	CT	86gr	14
	WP100	0,927"x15.7x2,25"	CS	108gr	14
	WP103	0,927"x14x2,75"	CS	154gr	14
	Ø23,813	WP043	15/16"x15x63	CT	124gr



Obwohl **FGM** ein verhältnismäßig junges Unternehmen ist, können wir auf einen großen Erfahrungsschatz unserer Mitarbeiter zurückgreifen.

*Even though **Forging Group Monale (FGM)** has been founded recently, their high quality production facility and knowledgeable staff have a high level of experience and technical ability in forging design and manufacturing.*



Das Schmieden ist ein sehr alter Arbeitsvorgang. Verschiedenartige Legierungen sind für diese Art von Verarbeitung geeignet. Die plastische Umformung, die durch diese Technik erzielt wird, ermöglicht die Herstellung von verschiedensten Teilen, die allesamt sehr hohen Belastungen standhalten, sehr kompakt sind und optimal weiterverarbeitet werden können.

*Forging manufacturing is a technical production process. Aluminum alloys are especially adapted for this kind of processing. The plastic deformation obtained by this technique enables the manufacturing of lightweight Aluminum products to be capable of withstanding high level of stress and to be finish shaped in to unique forged components which are extremely compact and very easy to work with.*

Wir verfügen über diverse Spindelpressen von 400 bis zu 1400 Tonnen, einer Hydraulischen Presse von 2500 Tonnen sowie 2 weiteren Hydraulischen Pressen von 1000 Tonnen.

Jede Presse verfügt über ihren eigenen Ofen zum Vorheizen. Diverse vollautomatische Sägemaschinen, Wärmebehandlungsöfen und eine automatische Picklingmaschine komplettieren die Produktionsstraße.

Mit den oben angesprochenen Anlagen sind wir in der Lage Aluminiumteile von ein paar Gramm bis hin zu mehreren Kilo Gewicht zu fertigen.

*FGM has a wide range of screw presses from 400 to 1400 tons, one mechanical press of 2500 tons and two hydraulic presses of 1000 tons.*

*Each press has its own pre-heating oven, sawing machines, heat-treatment ovens and an automatic pickling center to complete the forging production process.*

*FGM can produce forgings in Aluminum alloy, from a few grams to several kilos of weight depending on the client's requirements and needs.*

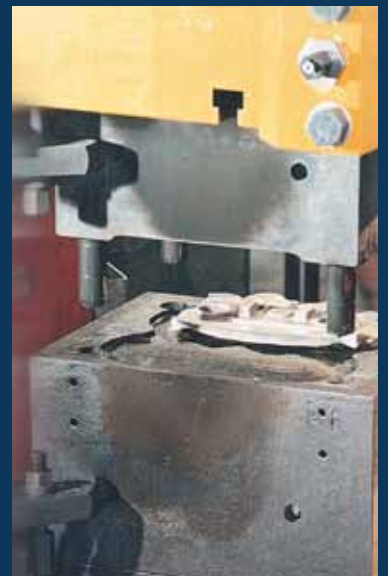



## Hinweise - Instructions

### INSTALLATIONSHINWEISE

**Diese Arbeiten müssen unbedingt von einem Fachmann ausgeführt werden!**

#### Kolbenlaufspiel

Wössner Kolben sind mit einer speziellen Ovalität versehen. Der Kolbendurchmesser wird an der dicksten Stelle des Kolbens gemessen. Diese befindet sich um 90° versetzt zum Kolbenbolzen, ca. 7 – 10 mm vom unteren Rand des Kolbenhemdes. Das Laufspiel ist auf der Verpackung angegeben.

#### Beschichtete Kolben

Das Kolbenlaufspiel wird ohne die Beschichtung des Kolbens berechnet. Die Beschichtung macht ca. 0,01 – 0,02 mm im Durchmesser aus.

#### Spaltmaße zum Zylinderkopf

Das Spaltmaß zwischen Dom und Zylinderkopf, sowie der Quetschkante muss vor dem Zusammenbau überprüft werden und muss den OEM Maßen entsprechen.

#### Spiel zwischen Ventilen und Kolben

Die Wössner Kolben werden in den meisten Fällen mit Ventiltaschen geliefert die tiefer sind als die der OEM Kolben. Es ist sehr wichtig, dass der Ventilhub vor dem Einbau der Kolben geprüft wird. Das ist notwendig, da es eine Vielzahl von Nockenwellen gibt, auch spielen hier Zylinderkopf/Blockhöhe eine Rolle.

### INSTALLATIONSHINWEISE 4-TAKT RINGE

Die Ringe müssen mit einer geeigneten Kolbenringzange eingebaut werden, wobei man mit dem untersten Ring anfängt. Übertriebenes Spreizen des Rings sollte verhindert werden, da dies zu einer Deformation des Rings führen kann. Wenn die Ringe deformiert sein sollten, sind sie nicht mehr zu verwenden. Ringe die eine Markierung besitzen, müssen innerhalb der Nute mit der Bezeichnung nach oben, in Richtung Zylinderkopf eingebaut werden. Besondere Sorgfalt gilt beim Einbau von dem Ölabbstreifring.

Achten Sie darauf, dass alle Ringstöße gleichmäßig versetzt sind.

#### Ringstoßspiel

Prüfen Sie die Verdichtungsringe auf das Stoßspiel, gegebenenfalls müssen Sie diese vorsichtig nacharbeiten. Multiplizieren Sie Ihren Zylinderdurchmesser in mm mit dem Faktor in der jeweiligen Zeile für Ihre Anwendung um das Ringstoßspiel zu bestimmen.

Beispiel: Für den ersten Ring eines ATV's mit 80,00 mm Bohrung multipliziert man  $80 \times 0,0040 = 0,32$  mm.

Anwendung / application	1ter Ring / top ring	2ter Ring / second ring	Öler Lamellen / oil ring rail
Motorrad und ATV	Bore x 0,0040	Bore x 0,0050	mind. 0,4 mm
HC Kolben für Motorräder	Bore x 0,0045	Bore x 0,0050	mind. 0,4 mm
Turbo Kolben für Motorräder	Bore x 0,0050	Bore x 0,0055	mind. 0,4 mm

Die obenstehende Tabelle gibt nur einen Richtwert an. Das Stoßspiel des zweiten Rings sollte immer größer sein, als das Stoßspiel des ersten Rings, um einem Flattern der Ringe entgegen zu wirken



### SPECIFICATIONS AND INSTALLATION INSTRUCTIONS

#### Piston to Cylinder Wall Clearance

Wössner pistons are designed with a special cam and cylinder design. When measuring for piston to wall clearance, measure at widest point of piston skirt from the bottom of the oil ring groove, 90 degrees from wrist pin hole.

#### Coated Pistons

Piston to wall clearance is calculated before the coating is applied to the piston skirts.

#### Dome Clearance

Dome to cylinder head clearance need to be checked prior to assembly.

#### Valve to Piston Clearance

Most Wössner pistons are designed with valve pockets that are deeper and larger than OEM. These pockets provide adequate valve clearance under most conditions. It is very important that valve to piston clearance is checked upon piston installation. This is necessary due to many variations in cams, how much a block has been decked, or if the heads have been cut or angle milled.

### INSTALLATION INSTRUCTIONS 4-STROKE RINGS

The rings are installed with suitable piston ring pliers, starting with the lowest ring. Excessive opening of the rings is to be avoided, since this could lead to deformation of the rings. If the rings are deformed, they are not longer able to provide a perfect seal. Rings that have the mark are to be fitted with the marking facing upwards towards the piston crown. Special care is needed for the installation of steel rail rings (3S-rings). After the spring has been loaded, the rails are to be mounted so that rail end gaps point towards the pin hole. When the upper rail is being installed, the ends of the spring needs to be held together so as to prevent overlapping. After this, the lower rail is to be installed. In the case of pistons with rotation prevention in the ring grooves, care need to be taken to ensure that the ring gaps are positioned alongside the location pins. After the rings have been installed, the ring gaps are to be spread evenly around the circumference (for example at 120° intervals for a 3-ring piston).



## Custom Piston Order Form

Fax to +49 (0) 7621 95 66 49-25

Engine Type \_\_\_\_\_  
 Model \_\_\_\_\_ Year \_\_\_\_\_  
 Number of Cylinders \_\_\_\_\_ Order Quantity of Pistons \_\_\_\_\_  
 Displacement \_\_\_\_\_ Max RPM \_\_\_\_\_ Approx. HP \_\_\_\_\_  
 Bore Size \_\_\_\_\_ Stroke \_\_\_\_\_  
 Rod Length \_\_\_\_\_  
 Rod Small-End Width \_\_\_\_\_  
 Thickness above Pin \_\_\_\_\_  
 Head Gasket Thickness \_\_\_\_\_  
 Compression Ratio \_\_\_\_\_

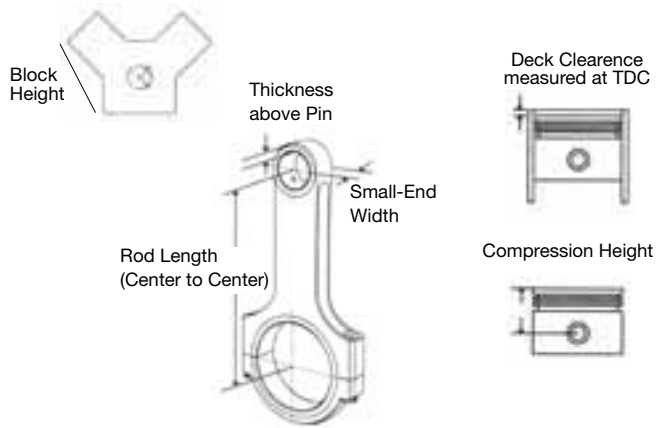

### CYLINDER HEAD

Combustion Chamber Size \_\_\_\_\_ cc's  
 Valve Diameter In \_\_\_\_\_ Ex \_\_\_\_\_  
 Free Drop (if known) \_\_\_\_\_  
 Was cylinder head milled?  Yes  No  
 If cylinder head was milled, how much?  
 Flat \_\_\_\_\_  Angled \_\_\_\_\_

Piston Type (Circle one if known)

Dome  Flat Top  Dish  Inverted Dome  
 Conical  Spherical  Round  3D

Pistons designed for  Circle Track  Asphalt  Dirt  
 Drag Race  Road Race  Marine  Street/Ship  
 other (please specify) \_\_\_\_\_

Is your Motor  Carbureted  Injected  
 Turbo Charged: Lbs. Boost \_\_\_\_\_  Blown: Lbs. Boost \_\_\_\_\_  
 Nitrous – how much HP  100  250  350  400+  
 other (please specify) \_\_\_\_\_  
 Fuel Type  Pump Gas  Race Gas  Alcohol  Nitro

### PIN SPECS

Pin Diameter \_\_\_\_\_ Length \_\_\_\_\_  
 Wall Thickness \_\_\_\_\_ Qty \_\_\_\_\_  
 Pins with Order  Yes  No  
 Pin Fit  Yes  No

**Wössner GmbH reserves the right to choose the appropriate pin length if supplying pins per each piston design.**

### COMPANY INFORMATION

Company \_\_\_\_\_  
 Contact Person \_\_\_\_\_  
 Street \_\_\_\_\_  
 Country \_\_\_\_\_  
 Phone \_\_\_\_\_  
 Fax \_\_\_\_\_  
 E-Mail \_\_\_\_\_

**RETURN POLICY:** Custom pistons are returnable only for defects in workmanship or materials in the as received condition. Under no circumstances will parts be returnable after 90 days. Please check packaging for complete details regarding return policy.





# ÄFTSBEDINGUNGEN

21 - 79576 Weil m Rhein/Märkt

6.3 Der Kunde ist zur Weiterveräußerung der Vorbehaltsware im ordentlichen Geschäftsgang berechtigt. Er tritt uns für diesen Fall schon jetzt alle aus der Weiterveräußerung resultierenden Forderungen ab. Wir werden diese Forderungen auf Verlangen des Kunden freigeben, soweit sie unsere Forderungen gegen den Kunden um mehr als 20% übersteigen.

## 7. Gewährleistung

7.1 Offensichtlich mangelhafte oder unvollständige Ware hat der Kunde unverzüglich zu rügen. Die Rüge muß spätestens 14 Tage nach Erhalt der Ware bei uns eingegangen sein. Die weitergehende Untersuchungs- und Rügepflicht von kaufmännischen Kunden richtet sich nach den gesetzlichen Vorschriften. Jede Beanstandung der Ware hat schriftlich unter Beifügung einer Rechnungskopie zu erfolgen.

7.2 Keiner Rüge bedürfen als solche gekennzeichnete Teilleistungen, zu denen wir in zumutbarem Umfang berechtigt sind. Keine Mängel sind solche Abweichungen von der verabredeten oder aus Anzeigen oder Katalogen ersichtlichen Beschaffenheit der Ware, die die Tauglichkeit zum gewöhnlichen oder vertragsgemäßen Zweck unberührt lassen oder verbessern. Entsprechende Änderungen behalten wir uns vor.

7.3 Unsere Motoren-, Tuning- und sonstige Zubehörteile werden überwiegend ohne TÜV-Gutachten geliefert und sind nur für Rennzwecke bestimmt. Die Zulässigkeit ihres Einsatzes auf öffentlichen Straßen gehört nicht zur vertragsgemäßen Beschaffenheit.

7.4 Die Gewährleistung für gelieferte Ware ist nach unserer Wahl auf Nachbesserung oder Ersatzlieferung beschränkt. Bei Fehlschlägen der Nachbesserung oder Ersatzlieferung kann der Kunde nach seiner Wahl, Herabsetzung der Vergütung oder Rückgängigmachung des Vertrags verlangen. Wir sind zu mindestens zwei Nachbesserungsversuchen berechtigt.

7.5 Beruht der aufgetretene Mangel auf unsachgemäßer Behandlung, Reparaturversuchen, Beschädigungen oder sonstigen Veränderungen der Ware durch den Kunden selbst oder Dritte, bestehen keine Gewährleistungsverpflichtung. Es entfällt insbesondere jeder Gewährleistungsanspruch des Kunden, wenn die der Ware beigefügte Einbauanleitung nicht genau befolgt wird.

7.6 Bei Auftragsarbeiten nach Kundenvorgabe leisten wir nur für handwerklich ordnungsgemäße Ausführung Gewähr. Das Risiko technisch bedingter Funktions- oder Haltbarkeitsmängel trägt der Kunde.

7.7 Stellen wir bei einer Beanstandung fest, daß wir nicht gewährleistungspflichtig sind, können wir vom Kunden für angefallenen Material- und Zeitaufwand eine angemessene Vergütung verlangen.

7.8 Die Gewährleistungszeit beträgt sechs Monate.

## 8. Haftung

8.1 Vertragliche vorvertragliche und außervertragliche Schadensersatzansprüche- unter Ausnahme von Ansprüchen wegen Fehlens zugesicherter Eigenschaften- sind ausgeschlossen, soweit wir den Schaden nicht vorsätzlich oder grob fahrlässig verursacht haben.

8.2 Bei Fehlen zugesicherter Eigenschaften haften wir nicht für Folgeschäden, es sei denn, die Zusage sollte gerade vor dem Eintritt solcher Folgeschäden schützen.

8.3 Darüberhinaus ist unsere Haftung gegenüber Kaufleuten auf den nach Grund und Höhe vorhersehbaren, vertragstypischen Durchschnittsschaden bis zum Zehnfachen des Kaufpreises b.z.w. Werklohns begrenzt, wenn uns nicht der Kunde vor Vertragsschluß schriftlich auf außergewöhnliche Schadensrisiken hingewiesen hat und wir schriftlich die Übernahme dieser Risiken erklärt haben.

8.4 Wir haften nicht für Schäden, die auf einer Nichtbeachtung der Einbauanleitung (Ziffer 7.5) oder auf der Befolgung von Kundenvorgaben (Ziffer 7.6) beruhen.

## 9. Schlußbestimmungen

9.1 Erfüllungsort ist 79576 Weil am Rhein. Bei Geschäften mit Vollkaufleuten, juristischen Personen des öffentlichen Rechts oder öffentlichrechtlichen Sondervermögen ist Gerichtsstand für alle im Zusammenhang mit diesem Vertrag entstehenden Rechtsstreitigkeiten 79576 Weil. Das gleiche gilt, wenn der Wohnsitz oder gewöhnliche Aufenthalt des Kunden im Zeitpunkt der Klageerhebung unbekannt ist oder sich im Ausland befindet.

9.2 Dieser Vertrag untersteht deutschem Recht. EKG und UN Kaufrecht finden keine Anwendung.

9.3 Sollten einzelne Bestandteile dieses Vertrags unwirksam sein oder werden, berührt dies nicht die Wirksamkeit des übrigen Vertrags.

# GENERAL TERMS AND CONDITIONS

of contracts with Wössner GmbH · Im Wörth 21 · 79576 Weil m Rhein/Märkt

## 1. General

All offers, deliveries, repairs and other services are exclusively rendered on the basis of the following conditions. The applicability of contractual partners' conflicting terms and conditions is herewith denied. Deviations from these terms and conditions have effect only if they are confirmed by us in writing. All other alterations, requested or implied, remain invalid. These Terms and Conditions supersede all previous Terms and Conditions

## 2. Contract-execution and Content

2.1 All offers are subject to confirmation within three weeks and are non-binding.  
2.2 Subsidiary agreements, restrictions, alterations or additions to contracts must be made and accepted in writing.

## 3. Prices and Terms of Payment

3.1 All prices exclude postage and packing.  
Offers are made based upon current costs. Should, between acceptance of an order and delivery date, an unexpected rise in costs occur, we reserve the right to raise our wholesale prices accordingly. The same applies to retail prices only when the delivery date is more than four months after the order was confirmed. An increase in price on a retail contract is restricted to three percent of the original sum.  
3.2 Only written estimates will be considered to be binding. Should we not receive a contract following an estimate we reserve the right to request an appropriate fee for this service.  
3.3 Payment, in Euro, is due in full within one week of the billing date.  
3.4 For delivery contracts we reserve the right to request payment in advance or cash on delivery.  
3.5 Payment by cheques and bills of exchange is only considered to have taken place when the clearing process is completed. Responsibility for the form and acceptance of bills of exchange remains with the drawee. Withdrawal, account and exchange fees are the responsibility of the purchaser and are immediately due.  
3.6 The purchaser is only entitled to an account credit in the event of an unchallenged and legally upheld counter claim. Right of retention claims must be based upon such claims.  
3.7 We reserve the right to off-set payments against outstanding debts in accordance with §§ 367 Abs. 1, 366 Abs. 2 BGB  
3.8 In the event of delay or default in payment we reserve the right to charge interest at a rate of two percent above the base rate as defined by the Deutsche Bundesbank.

## 4. Delivery Dates and Appointments

4.1 Delivery dates and working schedules are only binding when agreed in writing.  
4.2 In the event that we are unable to meet a delivery date, the customer is entitled to set a new delivery date, at least three weeks after the expiry of the original deadline. Only if this second deadline is reached without the delivery taking place is the customer entitled to withdraw from the agreement. The setting of deadlines and the withdrawal from agreements must take place in writing.  
4.3 Force Majeure – events beyond our control, such as, but not restricted to, acts of God, industrial action and state intervention, that hinder us or our suppliers in the completion of our work may lead to an extension of the previously agreed delivery times. Should such events render completion of a contract impossible or the altered conditions unacceptable then either party is entitled, in writing, to withdraw from the agreement. There arises no entitlement to compensation

## 5. Transfer of Responsibility

5.1 We are not liable for loss or damage in transport. Responsibility passes to the customer as the goods are collected or leave our premises. If dispatch is delayed due to events beyond our control then responsibility passes to the customer with the notification of transport readiness. An insurance to cover possible damage or loss during transportation can be arranged on request. The cost of the insurance is the responsibility of the customer.  
5.2 Responsibility for goods in transit to us remains with the customer.

## 6. Reservation of Title – Transfer of Ownership

6.1 The finished goods remain completely the property of Wössner GmbH until such time as all outstanding balances due to us have been paid. In the case of wholesale partners this clause also applies to future balances.  
6.2 If our sole ownership of the goods becomes void through amalgamation or modification, then we receive a proportional ownership of the new retained goods based upon the value of its constituent parts.  
6.3 The customer is entitled to process and sell the retained goods in the due course of his business. Any and all resulting income is payable to Wössner GmbH. Following a specific request from our customer we are willing to release them from this demand in so far as their income is more than twenty percent over our price.

## 7. Guarantee

7.1 Receipt of obviously faulty or incomplete goods must be immediately registered at Wössner GmbH. Notification must reach us within fourteen days of receipt of the goods. The extent of any further testing and the necessity of any further notification, in the case of trade customers, are legally governed. Any complaints concerning the goods must be forwarded in writing together with a copy of the relevant invoice.  
7.2 We reserve the right to dispatch part orders in appropriate circumstances. These will be clearly marked as such and require no notification of missing components. Deviations from agreed or advertised properties of a product that either improve or do not influence its normal or planned usage are not considered to be defects. We reserve the right to make such alterations.  
7.3 Our motor parts, tuning instruments and other accessories are generally delivered without TÜV testing and are only for use in specialised racing vehicles. Licensing for use on normal road vehicles is not part of any agreement.  
7.4 Our guarantee is limited to repair or replacement of the delivered goods. In the event of a further problem after repair or replacement the customer may choose between an appropriate reduction in price or return of the goods and a refund. We reserve the right to two attempts to improve the original merchandise before further action is taken.  
7.5 Faults directly or indirectly attributable to inappropriate handling, attempted repair, inflicted damage or other alterations to the goods carried out by the customer or a third party are not covered by our guarantee. The guarantee becomes void should the customer not follow exactly the instructions contained within the included Installation Manual.  
7.6 For special constructions based upon designs provided by the customer, our guarantee is restricted to the quality of the construction work carried out. All risks relating to technical specification, function and endurance are carried by the customer.  
7.7 Should we discover in the course of a complaints procedure that our guarantee is void, we reserve the right to charge the customer an appropriate fee for time and material costs.  
7.8 The guarantee period is six months.

## 8. Liability

8.1 Except for instances of gross negligence or intentional malpractice, compensation claims arising from positive violation of claims, breach of duty prior to contract (culpa in contrahendo) and from tort are excluded in all instances except those arising from claims based faulty goods.  
8.2 In cases of faulty merchandise liability is excluded for direct and consequential damage which occurs after the defect should reasonably have been identified.  
8.3 Furthermore the amount of compensation for cases involving wholesale transactions is, based upon the foreseeable average damage for this nature of contract, limited to ten times the price of the article or, in the case of modifications, ten times the works costs. Instances involving exceptional risk factors must be registered pre-contract. Liability beyond the limits outlined within this contract will only be accepted if agreed in writing in advance.  
8.4 Liability claims based upon a failure to follow the Installation instructions (Paragraph 7.5) or based upon damage caused as a result of an explicit customer request (Paragraph 7.6) are excluded.

## 9. Final Provisions

9.1 The place of fulfilment of this contract is 79576 Weil am Rhein, Germany. Insofar as the customer is a registered businessman within the bounds of the German Commercial Code, a legal entity under public law or a Special Fund under public law, the exclusive place of jurisdiction for all disputes arising directly or indirectly from the contractual relationship is 79576 Weil am Rhein. The current or usual place of residence of the plaintiff is immaterial.  
9.2 German law is applicable to these General Terms and Conditions and to the entire legal relations between us and the customer. Uniform Sales Law and the United Nations Convention on Contracts for the International Sale of Goods have no jurisdiction. The German version of these terms and Conditions (Allgemeine Geschäftsbedingungen) are binding in content.  
9.3 In the event that a condition in these General Terms and Conditions or a Provision under the structure of other agreements is, or will become invalid, this does not affect the validity of all other conditions or agreements.

## Our location in Germany



## Wössner GmbH

Im Wörth 21  
D-79578 Weil am Rhein/Markt  
Tel. +49 (0) 7621 95 66 49-0  
Fax +49 (0) 7621 95 66 49-25  
info@woessner-kolben.de  
www.woessner-kolben.de

### GEWÄHRLEISTUNGEN

Aufgrund der Natur leistungsstarker Motoren werden die Teile in diesen Sets ohne jegliche vertragliche oder gesetzliche Gewährleistung, insbesondere der Gewährleistung für die Verkaufsfähigkeit oder Eignung für einen bestimmten Zweck, verkauft. Die Wössner GmbH kann nicht, unter keinen Umständen, für spezielle oder zufällige Schäden, sowie Folgeschäden haftbar gemacht werden, dies beinhaltet, ist aber nicht darauf beschränkt, Beschädigung, Umsatzverlust, die Kosten für erworbene Teile oder Ersatzteile, weitergehende Forderungen der Kunden des Käufers, die aus dem Kauf hervorgehen und /oder ein Ergebnis dieser sind. Der Einbau dieser Teile kann die Herstellergarantie für das Fahrzeug negativ beeinflussen. Kolben sind für Rennsport-Zwecke zu verwenden.

### WARRANTY DISCLAIMER

*Due to the nature of performance applications, the parts in this kit are sold without any express warranty or any implied warranty of merchantability or fitness for a particular purpose. Wössner GmbH shall not, under any circumstances, be liable for any special, incidental or consequential damages, including, but not limited to damage, or loss of profits or revenue, cost of purchased or replacement goods, or claims of customers of the purchaser, which may arise and / or result from sale, installation or use of these parts. Installation of these parts could adversely affect the vehicle manufacturer's warranty co-verage. Pistons are usable for racing.*

Wir danken für die Fotos von Bert Swarts, Thomas Bauerschmidt, Jörg Gaedtke, Elmar Geulen, Herman Jolink, Johan Luyten, Wolfgang Radzuzweit, Hanna Retz und Verena Schmidt.

*Photos with friendly permission of Bert Swarts, Thomas Bauerschmidt, Jörg Gaedtke, Elmar Geulen, Herman Jolink, Johan Luyten, Wolfgang Radzuzweit, Hanna Retz and Verena Schmidt.*

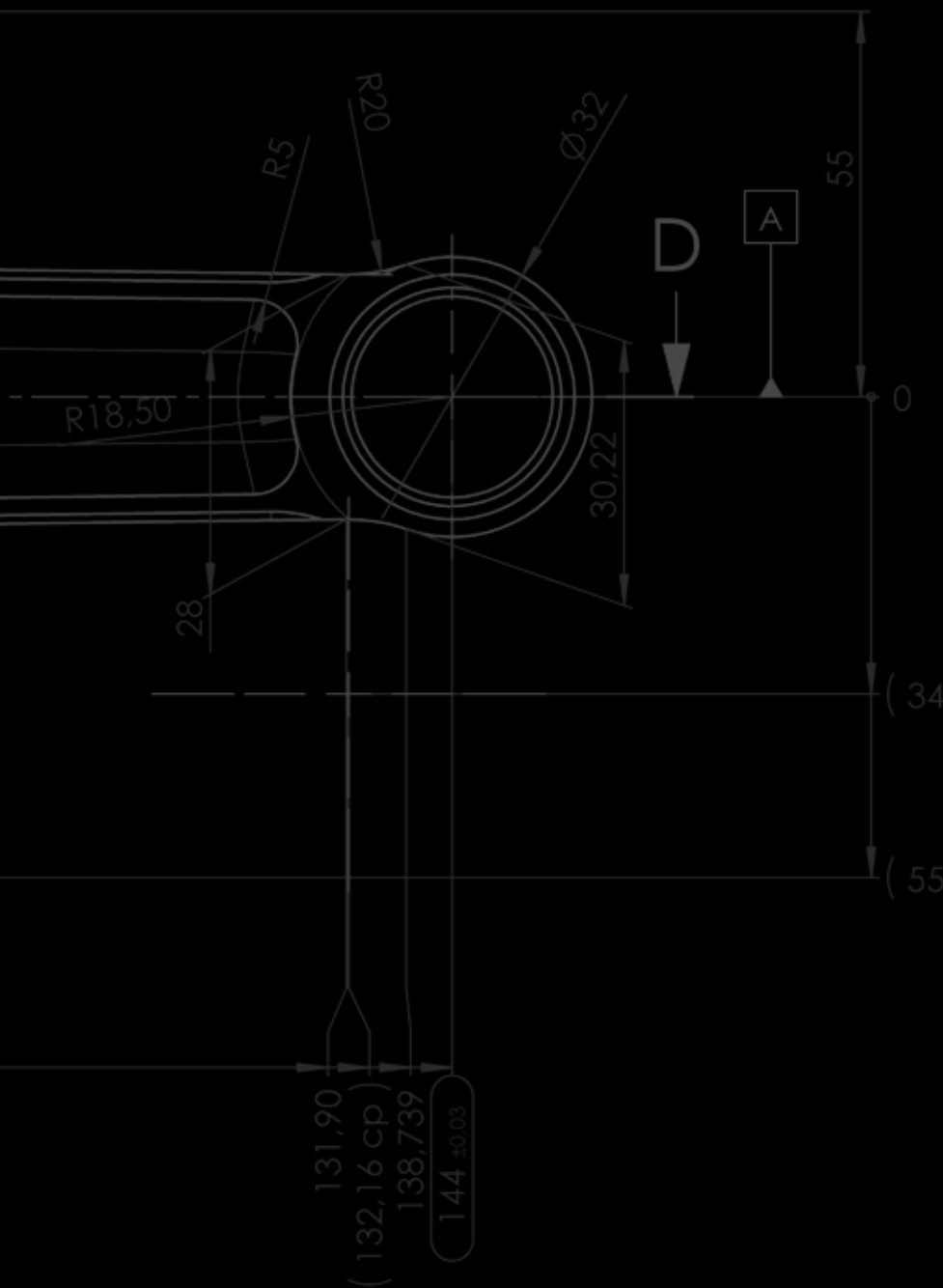

## Headquarters

**Wössner GmbH**  
 Im Wörth 21  
 D-79576 Weil am Rhein/Märkt  
 Tel. +49 (0) 7621 95 66 49-0  
 Fax +49 (0) 7621 95 66 49-25  
 info@woessner-kolben.de  
 www.woessner-kolben.de