

**CRUISER 250**



# CRUISER 250

## F01 STEERING CONTROL

NO	CODE	EN DESCRIPTION	QTY	NOTES	Season
1	40210K2GP000	GRIP ASSY., THROTTLE	1		
2	40600N0LP001	SWITCH ASSY., R.	1		
3	40101N0LP000	HANDLEBAR	1		
4	40500N0LP00A	SWITCH ASSY., L.	1		
5	40070K2GP000	GRIP ASSY., HANDLE, L.	1		
6	40080K2GP000	LEVER, L.	1		
7	40701N0JP000	RUBBER GROMMET BRAKE LEVER	1		
8	40710N0JP000	PEDAL ASSY., BRAKE	1		
9	40720N0LP000	ASSY., BRACKET	1		
10	40270N0LP000	REAR BRAKE LEVER ASSY	1		
11	40702N0HP000	SPRING, BRAKE RETURN	1		
12	B01020602064	BOLT 6x20MM	2		
13	40730N0LP000	BRACKET ASSY,BRAKE PEDAL	1		
14	08370N0JP000	LEVER ASSY., GEAR SHIFT	1		
15	08029J00P000	WASHER 12MM	1		
16	B08010001201	CIR-CLIP 12	1		
17	40300N0JP000	CABLE ASSY.I, THROTTLE	1		
18	40350N0HP000	CHOKE CABLE	1		
19	72900N0JP000	CABLE ASSY,SPEEDOMETER	1		
20	40400N0JP000	CABLE ASSY.,CLUTCH	1		
21	B01090801664	BOLT 8X16MM	1		
22	B02050605564	SCREW 6X55MM	2		
23	40031K2GP000	BALANCER	2		
24	40033K2GP000	PLUG, RUBBER	2		
25	B04070600054	NUT 6MM	2		
26	40470K2GP000	MIRROR ASSY., RR. VIEW, R.	1		
27	40460K2GP000	MIRROR ASSY., RR. VIEW, L.	1		
28	B04000800054	NUT 8mm	2		
29	B04220800044	NUT 8mm	2		
30	40081K2GP000	COVER,LEVER BRKT,UPPER	1		
31	40082K2GP000	COVER,LEVER BRKT,LOWER	1		
32	40084K2GP000	LEVEL,L	1		
33	40083K2GP000	BLOT	1		
34	B07030000405	WASHER 4MM	1		
35	B08010001000	CIR-CLIP 10MM	1		
36	40089K2GP000	SPRING	1		
37	40086K2GP000	SCREW	2		
38	40087K2GP000	BOLT	1		
39	40011N0LP000	PROTECTIVE RING	1		
40	96002N0HP000	BAND 200	2		
41	B01090801654	BOLT 8X16MM	2		
42	B02000401225	SCREW 4X12MM	1		
43	B04070600054	NUT 6MM	1		
44	40724N0LP000	BRACKET PLATE	1		
45	B0703000080L	WASHER 8	2		
46	91800J0FP000	SWITCH,CLUTCH	1		

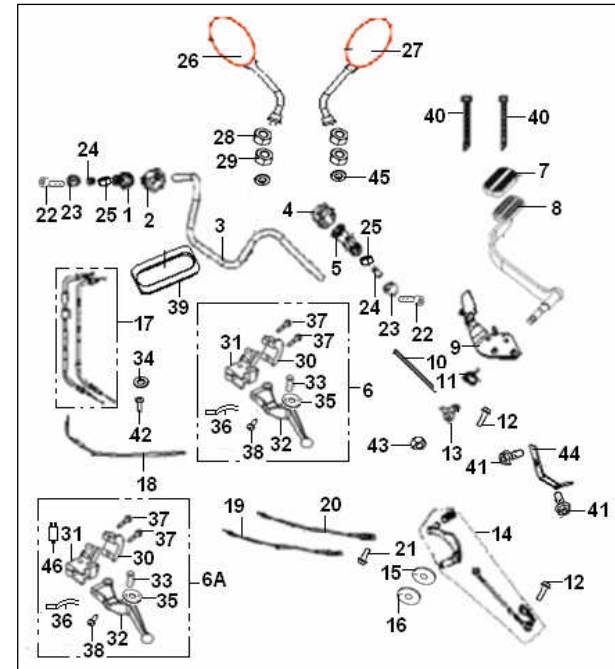

# CRUISER 250

## F02 FRONT FORK

NO	CODE	EN DESCRIPTION	QTY	NOTES
1	43014K2GP001	BARK.,HANDLEBAR,UPPER	1	
2	43013K2GP000	BARK.,HANDLEBAR,LOWER	2	
3	43011N0JP000	UPPER BRACKET	1	
4	43100N0JP000	LOWER BRACKET ASSY	1	
5	86402N0LP000	FRONT REFLECTOR ,RH	1	
6	08001N0JP000	SCREW 6X16MM	4	
7	43300N0LP000	ABSORBER ASSY.,FR.,R.	1	
8	43200N0LP000	ABSORBER ASSY.,FR.,L.	1	
9	08011K3AP000	BOLT	2	
10	43049J00P000	BOLT,STEM FIXING	1	
11	43044K3AP000	WASHER.UPPER	1	
12	43017G0KP000	NUT	1	
13	43005K3AP000	DUST COVER	1	
14	43001K2FP000	RACE, UPPER STEERING, UPPER	1	
15	43002G0KP000	RACE, UPPER STEERING, LOWER	1	
16	43003G0KP000	RACE, LOWER STEERING, UPPER	1	
17	43004K2FP000	RACE, LOWER STEERING, LOWER	1	
18	B06010200000	STEEL BALL SR6.35	38	unidade
19	43012N0JP000	DECORATION BOARD	1	
20	43053N0JP000	FR.,L COVER ,ABSORBER ASSY.	1	
21	43054N0JP000	FR.,R COVER ,ABSORBER ASSY.	1	
22	08510N0LP000	BRACKET WELDASSY.,TURN LAMP	1	
23	43470N0JP000	DECORATION BOARD ASSY	1	
24	43440N0JP000	DECORATION BOARD ASSY	1	
25	43035N0JP000	HOLDER,HOSE ASSY, FR. BRAKE	1	
26	B0205080256L	SCREW 8x25MM	4	
27	B07000000804	WASHER 8MM	2	
28	B07030000804	WASHER 8MM	2	
29	B01020804064	BOLT 8X40MM	2	
30	B01090601264	BOLT 6X12MM	4	
31	B01090601054	BOLT 6X10MM	9	
32	B04171000054	NUT 10MM	2	
33	B02050803564	SCREW 8x35MM	2	
34	43021N0JP000	HOLDER,FR BRAKE	1	
35	86302N0LP000	FRONT REFLECTOR ,LH	1	

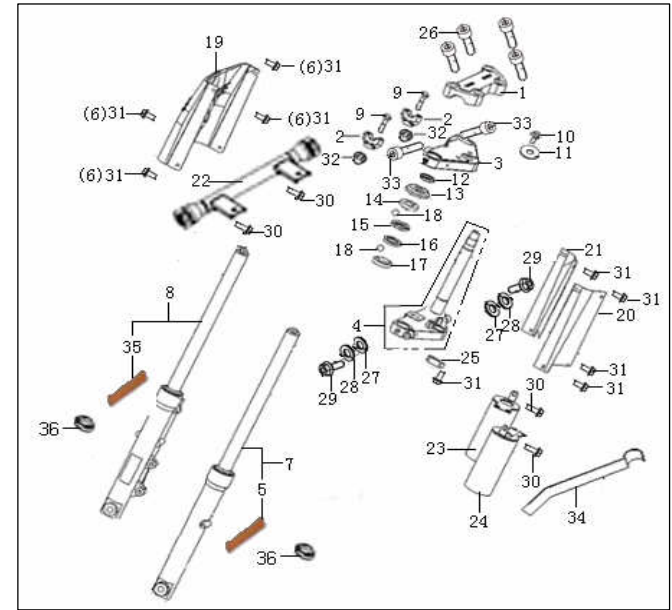

## CRUISER 250

36 43260N070000 OIL SEAL

2

### F03 FRONT WHEEL

NO	CODE	EN DESCRIPTION	QTY	NOTES
1	44004N0JP000	AXLE, FRONT WHEEL	1	
2	44005N0JP000	SPACER, FRONT WHEEL, L.	1	
3	44300N0JP000	DUST SEAL	1	
4	B12016030200	BEARING 60302-2RS	2	
5	44600N0JP000	SPACER, MID, FR. WHEEL	1	
6	44200N0JP001	GEAR BOX ASSY., SPEEDOMETER	1	
7	B04171415064	BOLT 14X1.5MM	1	
8	B140506F1621	TIRE 110/90-16	1	
9	45036N0JP000	BOLT, FIXING	6	
10	45033N0JP000	BRAKE DISK	1	
11	44101N0JPCE1	RIM, FRONT WHEEL(SILVER)	1	
12	B1404Z201130	CAP, VALVE	1	
13	B1403Z1102A0	NIPPLE, VALVE	1	

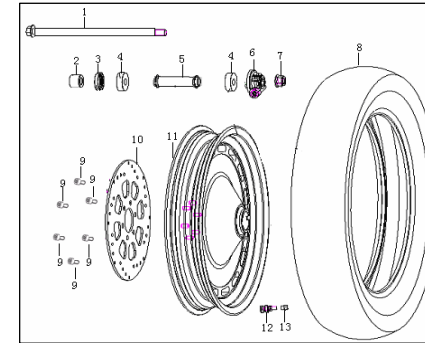

### F04 DISK BRAKE

NO	CODE	EN DESCRIPTION	QTY	NOTES
1	45000N0JP000	DISK BRAKE ASSY.	1	
2	B01070602465	BOLT 6X24MM	2	
3	40083K2GP000	BOLT	1	
4	B08010001000	CIR-CLIP 10MM	1	
5	45037K2FP000	BOLT,	2	
6	45029K2FP000	WASHER	4	
7	45039N0JP000	BOLT 10X1.25X43MM	2	
8	45400K2GP000	MASTER CYLINDER ASSY.	1	
9	45500N0JP000	CALIPER ASSY.	1	
10	45200N0JP000	HOSE ASSY, FR. BRAKE	1	
11	45022K2GP000	LEVER, DISK BRAKE	1	
12	45023K2GP000	COVER	1	
13	45110N0JP001	DISC BRAKE PAD ASSY	1 set	JOGO

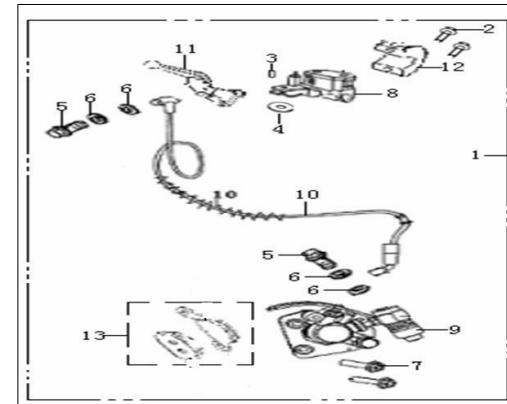

## CRUISER 250

### F05 MUFFLER

NO	CODE	EN DESCRIPTION	QTY	NOTES
1	47800N0HP000	GASKET, EXHAUST PIPE	2	
2	47100N07000B	MUFFLER JOINTING ASSY.A ( FRONT CYLINDER )	1	
3	48100N07000B	MUFFLER JOINTING ASSY.B ( BACK CYLINDER )	1	
4	47772N0LP000	DECORATE BOARD 3	1	
5	47016N0JP000	WASHER	14	
6	47761N0LP000	DECORATE BOARD 1	1	
7	47771N0LP000	DECORATE BOARD 2	1	
8	47006JOAP000	NUT 6MM	4	
9	B02551001664	SCREW 10×1.25×16MM	2	
10	B04181012554	NUT 10X1.25MM	1	
11	B1306060100L	SCREW 6×10MM	3	
12	B13060601204	SCREW 6×12MM	4	
13	B07030001004	WASHER 10MM	1	

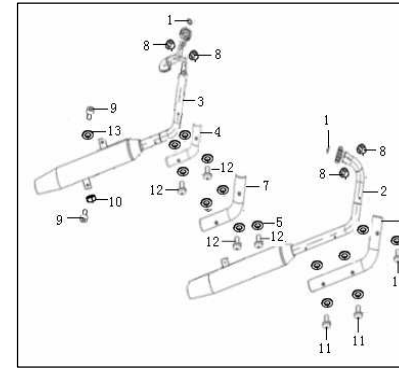

### F06 AIR CLEANER

NO	CODE	EN DESCRIPTION	QTY	NOTES
1	49000N0JP001	AIR CLEANER ASSY.COMP	1	
2	49350N0HP000	CLAMP ASSY	2	
3	49360N0JP000	BRACKET,AIR CLEANER	1	
4	B01070601064	BOLT 6X10MM	6	
5	49340N0JP000	BRACKET,AIR CLEANER	1	
6	B16010823101	HOSE,BREATHER	1	
7	49208N0HP000	FILTER ELEMENT	1	
8	49001N0HP000	COVER,AIR CLEANER	1	
9	49013N0HP000	SEAL RING ,AIR CLEANER	1	
10	49370N0HP000	CLIP	1	
11	49014N0HP000	CONNECTING HOSE	1	
12	B02000602004	BOLT 6×20MM	2	
13	49700N0JP00A	COVER DECORATION ASSY	1	
14	49701N0HP000	COVER DECORATION	1	
15	49710N0JP00A	BRACKET COVER DECORATION	1	
16	49702N0JP000	BRACKET,DECORATION	1	
17	B01070602265	BOLT 6×22MM	2	
18	B02000604024	SCREW 6×40MM	4	
19	B02000603024	SCREW 6×30MM	2	
20	B07000000604	WASHER 6MM	2	
21	B07030000604	WASHER 6MM	4	
22	49002N0HP000	INTAKE	1	
23	49207N0HP000	HOLDER , FILTER ELEMENT	1	
24	49025N0HP000	SUPPORT PLATE, FITER ELEMENT	1	
25	B07020000602	WASHER 6MM	1	
26	B04000500052	NUT 5MM	1	

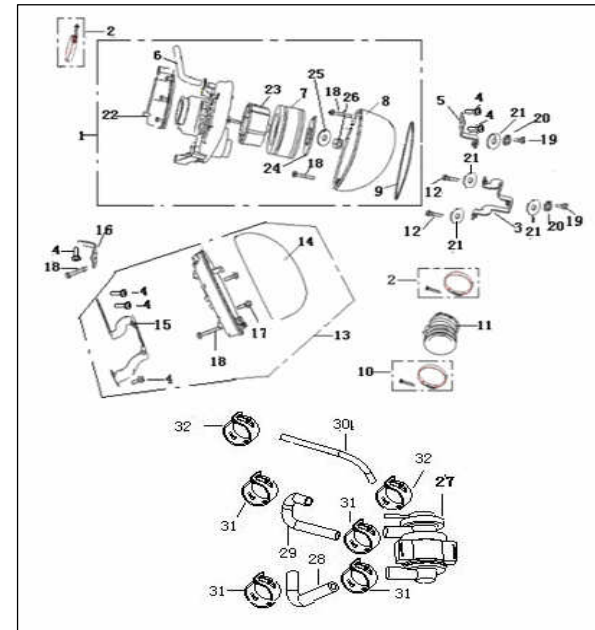

# CRUISER 250

## F07 FUEL TANK

NO	CODE	EN DESCRIPTION	QTY	NOTES
1	50100N07001Z	FUEL TANK JOINTING ASSY.	1	PRT
	50100N07002Z	FUEL TANK JOINTING ASSY.	1	CZ
	50100N07003Z	FUEL TANK JOINTING ASSY.	1	LARANJA
2	50116N0JP000	CAP, FUEL TANK DECORATION	1	
3	50117N0JP000	CUSHION	1	
4	50310N0LP000	fuel cock	1	
5	50005N0HP000	CUSHION, FUEL TANK, FR.	2	
6	50006N0JP000	CUSHION, FUEL TANK, RR.	1	
7	50025N0JP00A	BRACKET,FUEL TANK FIXING	1	
8	B16010401803	HOSE 4X8X180	1	
9	B160165A1801	HOSE 6.5X11X180	1	
10	B17010080003	CLIP	2	
11	B17010100003	CLIP	2	
12	08013N050000	BOLT	3	
13	B07020000601	WASHER 6MM	1	
14	B04070600055	NUT 6MM	1	
15	B01090601254	BOLT 6X12MM	2	
16	B0703000050L	WASHER 5MM	3	
17	50008N0HP000	3-DIRECTIONS PIPE	1	
18	50017N0HP000	SLEEVE, HOSE	2	
19	50720N0HP000	fuel pump assy	1	
20	50306N0HP000	CLIP	8	
21	50022N0HP000	BRACKET, SHUTOFF	1	
22	B16010722001	HOSE φ6×φ11×200	1	
23	B16010421701	HOSE φ4×φ8×170	1	
24	B16010722351	HOSE φ6×φ11×235	1	
25	B16010721501	HOSE φ6×φ11×150	1	
26	B16010720501	HOSE φ6×φ11×50	1	
27	B07000000604	SPRING WASHER 6MM	2	
28	B0200060162L	SCREW 6X16MM	2	
29	B07030000604	WASHER 6MM	2	
30	50307N0HP000	CLIP φ8.5	1	
31	49806J00P000	CLIP 7.5	1	

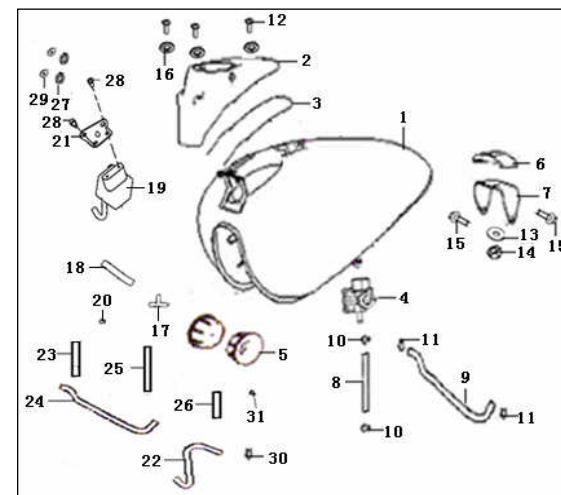

## CRUISER 250

### F08 SEAT

NO	CODE	EN DESCRIPTION	QTY	NOTES
1	51100N0LP000	SEAT I	1	
2	51200N0LP000	SEAT II (Logo "KEEWAY")	1	
3	B01090801264	BOLT 8X12MM	1	
4	B01090801664	BOLT 8X16MM	1	
5	B0703000080C	WASHER 8MM	2	
6	51013N0LP000	RUBBER CUSHION	1	

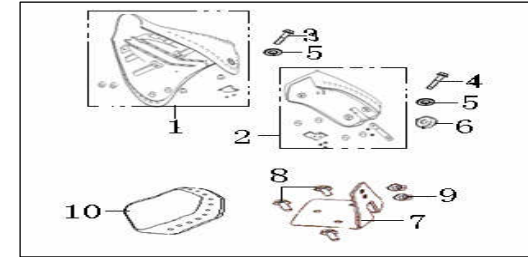

### F09 REAR SWINGING ARM

NO	CODE	EN DESCRIPTION	QTY	NOTES
1	53100N0LP001	REAR SWINGING ARM COMP.	1	
2	53001N0JP000	SHAFT, PIVOT	1	
3	53007N0LP000	SPACER, SWINGING ARM	2	
4	B1210K490100	BEARING	2	
5	B04171212564	NUT 12X1.25MM	1	
6	53230N0LP000	ADJUSTER COMP., CHAIN	2	
7	53234N0LP000	FIXING PLATE, ADJUSTER	2	
8	B04000800054	NUT 8MM	2	
9	53004N0LP000	BUFFER, CHAIN TOUCH DEFENSE	1	
10	B02010501025	SCREW 5X10MM	4	
11	53009N0JP000	CLIP	2	
12	B02010601024	SCREW 6X10MM	2	
13	53210N0LP000	OIL SEAL	4	

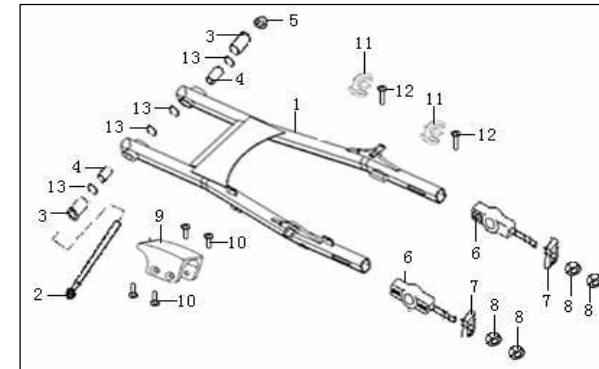

# CRUISER 250

## F10 REAR WHEEL

NO	CODE	EN DESCRIPTION	QTY	NOTES
1	44004N0JP000	AXLE, FRONT WHEEL	1	
2	60007N0LP000	SPACER, RR. WHEEL, L.	1	
3	60200N0JP000	OIL SEAL	1	
4	B12016030400	BEARING 60304-2RS	1	
5	B04001012564	NUT 10X1.25MM	4	
6	60015N0JP000	BOLT, SPROCKET	4	
7	60004N0LP000	LOCK WASHER	2	
8	60002N0JP000	SPROKET,CHAIN	1	
9	60001N0JP000	HUB, SPROCKET	1	
10	54024N0JP000	CUSHION,RR,WHEEL	4	
11	60006N0JP000	SPACER, SPROCKET	1	
12	B12016030200	BEARING 60302-2RS	2	
13	54101N0JPCE1	RIM, RR. WHEEL(SILVER)	1	
14	B140507F1621	TIRE 120/90-16	1	
15	55033N0JP000	BREAK DISC,RR,	1	
16	45036N0JP000	BOLT, FIXING	5	
17	54550N0JP000	MID SPACER, RR. WHEEL	1	
18	54300N0JP000	OIL SEAL	1	
19	54005N0JP000	SPACER, RR. WHEEL, R.	1	
20	B04171415064	NUT M16X1.5	1	
21	B1403Z201130	NIPPLE, VALVE	1	
22	B1404Z201130	CAP, VALVE	1	
23	B1501C1118B0	DRIVE CHAIN 10MA-1X118	1	

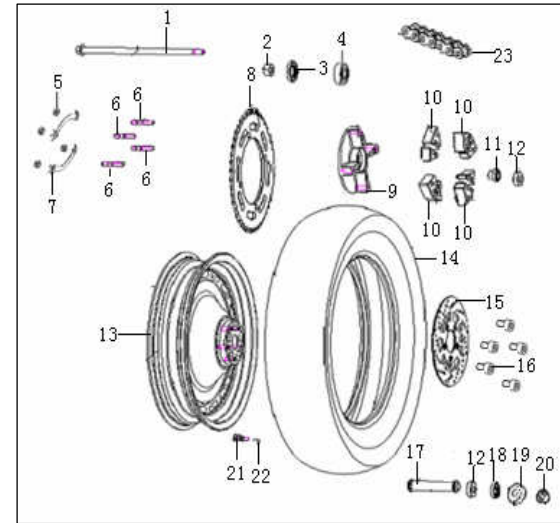

## F11 BACK DISK BRAKE

NO	CODE	EN DESCRIPTION	QTY	NOTES
1	55000N0LP001	REAR DISK BRAKE ASSY	1	
2	55140N0JP000	OIL CUP	1	
3	55131N0JP000	SPRING I, LOCK	2	
4	55220N0JP000	HOSE, FR. BRAKE(DOT)	1	
5	55400N0JP000	MASTER CYLINDER	1	
6	55210N0JP000	HOSE, FR. BRAKE(DOT)	1	
7	55500N0JP000	CALIPER ASSY.	1	
8	55300N0LP000	BRACKET	1	
9	B01090602564	BOLT 6X25MM	2	
10	B01090801664	BOLT 8X16MM	2	
11	B01090601264	BOLT 6X12MM	1	
12	91080N0LP000	SWITCH REAR BRAKE	1	
13	55110N0JP001	DISC BRAKE PAD ASSY	1 set	JOGO

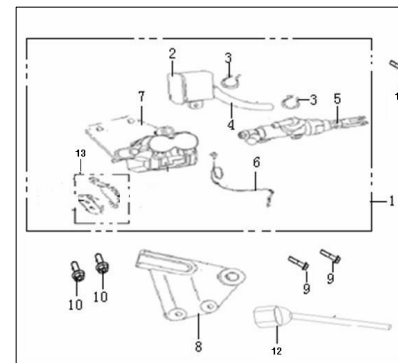



# CRUISER 250

## F12 FRAME

NO	CODE	EN DESCRIPTION	QTY	NOTES
1	57100N0LP000	FRAME BODY ASSY.	1	
2	58770N0HP000	BRACKET, IGNITION COIL	1	
4	57011N0HP000	BRACKET, ENGINE, FR.	2	
5	B04221012564	NUT 10X1.25MM	4	
6	58220N0JP000	BRACKET, FR. L. FOOTREST	1	
7	57008N0HP000	UPPER BRACKET, ENGINE, R.	1	
8	57009N0HP00A	LOWER BRACKET, ENGINE, R.	1	
9	58303N0HP000	SHAFT, ENGINE, FR.	1	
10	58229N0HP000	SLEEVE,RUBBER	8	
11	58228N0HP000	BUSH I	4	
12	B07020001004	WASHER 10MM	4	
13	57024N020010	BOLT, FOOTREST FIXING	4	
14	58450N0JP00A	SEAT, FOOTREST.L	1	
15	58470N0JP00A	SEAT, FOOTREST.R	1	
16	58230N0JP000	FOOTREST ASSY.	2	
17	58210N0JP000	FOOTREST ASSY.	2	
18	57005N0JP000	BOLT, SIDE STAND MOUNTING	1	
19	58701N0JP00A	SIDE STAND ASSY.	1	
20	57010N0LP000	SPRING, SIDE STAND	1	
21	58270N0JP000	BRACKET, L., RR., FOOTREST	1	
22	58290N0LP001	BRACKET, R., RR., FOOTREST	1	
23	58260N30P000	FOOTREST ASSY., RR., L.	1	
24	58280N30P000	FOOTREST ASSY., RR., R.	1	
25	96002N0HP000	BAND II 200	1	
26	96001N0HP000	BAND I 150	7	
28	B01090601264	BOLT 6x12MM	1	
30	B04070000854	NUT 8MM	3	
31	B01090811064	BOLT 8X110MM	2	
32	B01090801664	BOLT 8x16MM	5	
33	B01090802064	BOLT 8x20MM	2	
34	B01090811864	BOLT 8X118MM	2	
35	B04070800054	NUT 8MM	2	
36	B04001012564	NUT 10x1.25MM	1	
37	08431N0HP000	CLIP 16mm	2	
38	08402N0LP000	HOSE	1	
39	58702N0LP000	BRACKET	1	
40	B02050501564	SCREW 5X15MM	1	
41	B07000000504	WASHER 5MM	1	

## F13 SPROCKET

NO	CODE	EN DESCRIPTION	QTY	NOTES
1	60101N0LP001	CASE,BELT ,UPPER	1	
2	60102N0LP000	CASE, BELT ,BELOW	1	
3	B01090601064	BOLT 6X10MM	5	

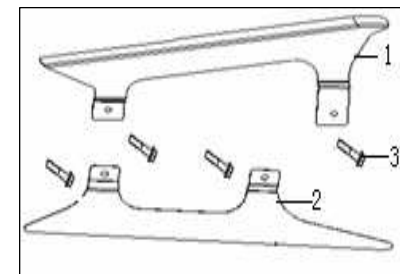
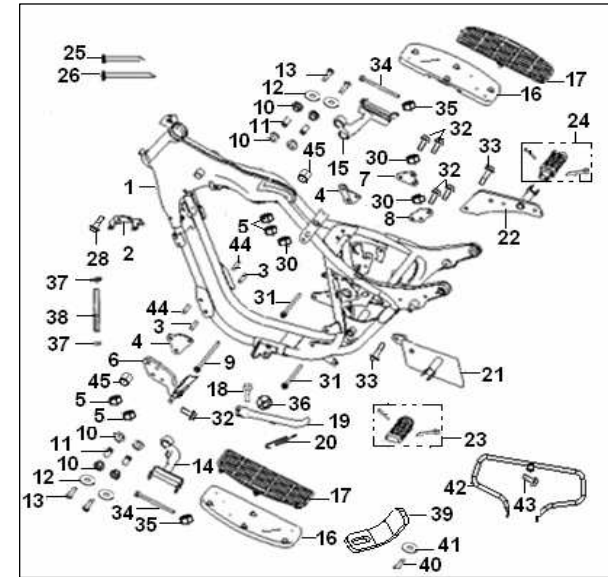

## CRUISER 250

### F14 REAR ABSORBER

NO	CODE	EN DESCRIPTION
1	63000N0JP000	REAR ABSORBER ASSY.
2	63013G0KP000	WASHER, UPPER, REAR ABSORBER
3	63014G0KP000	WASHER, LOWER, REAR ABSORBER
4	B01090801664	BOLT 8×16MM

QTY
2
2
2
4

NOTES

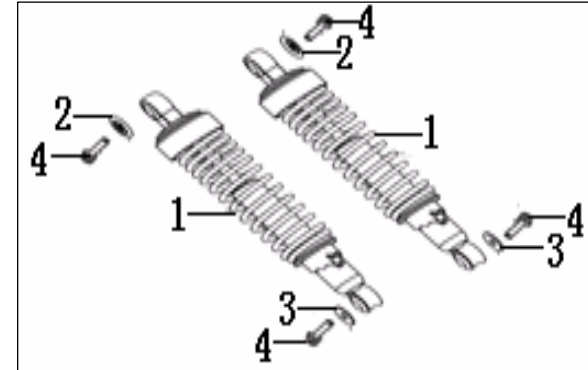

### F15 FRONT FENDER

NO	CODE	EN DESCRIPTION
1	65101N0LPBH0	FRONT FENDER
	65101N0LPCE0	FRONT FENDER
	65101N0LPX0	FRONT FENDER
2	B01090601264	BOLT 6X12MM
3	65105JCCT000	RING

QTY
1
1
1
4
1

PRT

CZ

LARANJA

NOTES

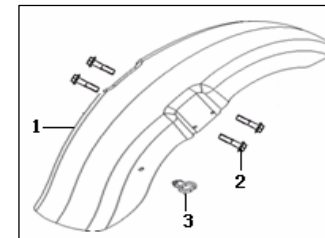

### F16 WINDSHIELD

NO	CODE	EN DESCRIPTION
1	65514N0JP000	MOUNTING PLATE WINDSHIELD
2	65515N0JP00A	MOUNTING PLATE UPPER
3	65508N0JP000	CUSHION WASHER I
4	65509N0JP000	CUSHION WASHER II
5	65503N0JP001	WINDSHIELD
6	65109G00P000	CUSHION WASHER
7	65530N0JP000	BRKT,ASSY. L
8	65520N0JP000	BRKT,ASSY. R
9	B07020000604	WASHER 6MM
10	B02000601624	SCREW 6X16MM
11	B04220600024	CAP NUT 6 mm
12	65551N0JP000	BUSH
13	B02000602024	SCREW 6X20MM

QTY
2
1
1
4
1
3
1
1
3
7
9
9
2

NOTES

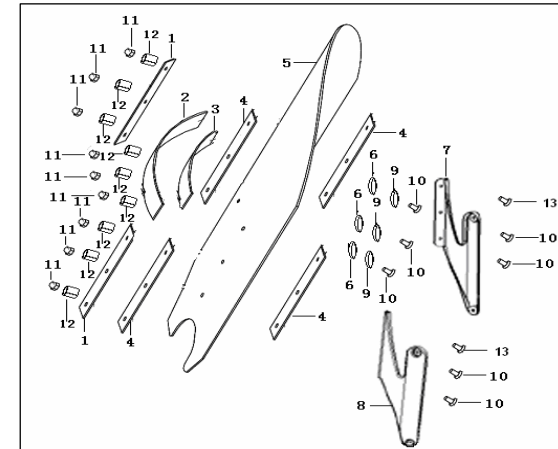

## CRUISER 250

### F17 FRAME COVER

NO	CODE	EN DESCRIPTION
1	65601N0HP001	FRAME COVER, L.
2	65602N0HP001	FRAME COVER, R.
3	65616N0HP000	CUSHION, FRAME COVER I
4	65618N0HP000	CUSHION, FRAME COVER II

QTY
1
1
2
4

NOTES

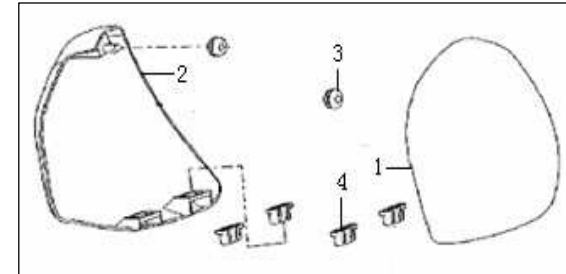

### F18 REAR FENDER

NO	CODE	EN DESCRIPTION
1	65701N0LPBH1	REAR FENDER
	65701N0LPCE1	REAR FENDER
	65701N0LPX1	REAR FENDER
2	65720N0LP000	REINFORCEMENT ASSY
3	65960N0LP00A	RIGHT ORNAMENT OF REAR FENDER
4	65950N0LP00A	LEFT ORNAMENT OF REAR FENDER
5	65971N0LP000	REAR HAND RAIL
6	54018K00P000	RING
7	08207N0JP000	PLATE ASSY.
8	08210N0LP000	BRACKET ASSY.
9	08204N0JP000	PLATE
10	65718N0JP000	FIX-IGNITION
11	B01090601664	BOLT 6X16MM
12	52009JJ0P000	BUSH
13	52300K2GP001	BRACKET ,BAG LH
14	52400K2GP001	BRACKET ,BAG RH
15	B02050808564	SCREW 8X85MM
16	B04070800064	NUT 8MM
17	B01090601254	BLOT 6X12MM
18	B01090602554	BLOT 6X25MM
19	B01010601655	BLOT 6X16MM
20	B04070000655	NUT 6MM
21	B01091006864	BOLT 10X1.25X68MM
22	51304K0BP000	BUSH
23	B04171012564	NUT 10X1.25MM
24	B01091002064	BOLT 10X20MM
25	52250K230010	BAG..L.
26	52260K230010	BAG..R.
27	82015K2GP000	BUSH
28	86500N0LP000	REAR REFLECTOR
30	65703K2GP000	RUBBER
31	B07000000605	WASHER 6MM
32	B07030000605	WASHER 6MM
33	65723N0JP000	LID
34	B07030001000	WASHER 10MM
35	B04000600053	NUT 6MM
36	B07020000603	WASHER 6MM

QTY

1	PRT
1	CZ
1	LARANJA
1	
1	
1	
1	
1	
1	
1	
1	
2	
2	
2	
2	
4	
1	
2	
2	
4	
6	
2	
2	
2	
2	
2	
2	
1	
1	
1	
4	
4	
1	
1	
2	
2	
1	
1	
1	

NOTES

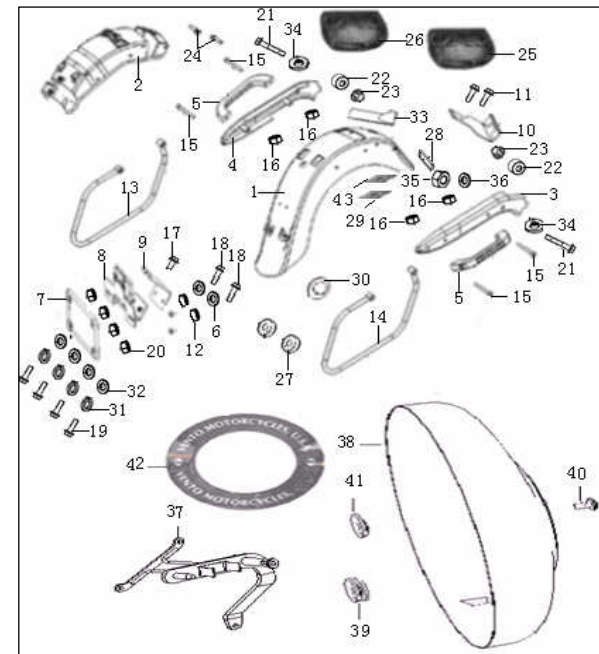

## CRUISER 250

### F19 ELECTRIC I

NO	CODE	EN DESCRIPTION	QTY	NOTES
1	80000N0LP000	HEAD LAMP ASSY.	1	
2	80025N0JP000	RIM, HEAD LIGHT	1	
3	80004N0JP001	COVER,HEADLIGHT	1	
4	80006N0JP000	BOWL., HEAD LIGHT	1	
5	80022N0JP000	BULB HOLDER, Fr. POSITION LIGHT	1	
6	80024N0JP000	RING	3	
7	B24010520000	BULB , HEAD LIGHT12V/35W	1	
8	80003N0JP000	BULB HOLDER, HEADLIGHT	1	
9	B24012220000	BULB, Fr. POSITION LIGHT 12V/4W	1	
10	80007N0JP000	BASE, HEADLIGHT	1	
11	B02000501624	SCREW 5X16 MM	2	
12	08331N0JP000	RUBBER WASHER	4	
13	08344N0JP000	SPACER	2	
14	B01090605564	BOLT 6X55MM	2	
15	B04070600064	NUT 6MM	2	
16	80030N0JP000	BASE, HEAD LAMP	1	
17	B04171000064	NUT 10MM	1	
18	82000N0LP000	TAIL LAMP ASSY.	1	
19	82003N0JP000	BASE,TAIL LAMP	1	
20	B04020500065	NUT 5MM	2	
21	B07030000604	WASHER 6MM	2	
22	B04000600053	NUT 6MM	2	
23	82900K2GP001	WIRE ASSY., TAIL LIGHT	1	
24	82012K2GP001	FRAME,TAIL LAMP	1	
25	B24013820000	BULB, TAIL LIGHT 12V21W/5W	1	
26	82008K2GP000	COVER, TAIL LIGHT	1	
27	B02000401024	SCREW 4X10MM	2	
28	70000N0LP000	SPEEDOMETER ASSY.	1	
29	50014N0JP000	BUSH	2	
30	B07020000501	WASHER 5MM	2	

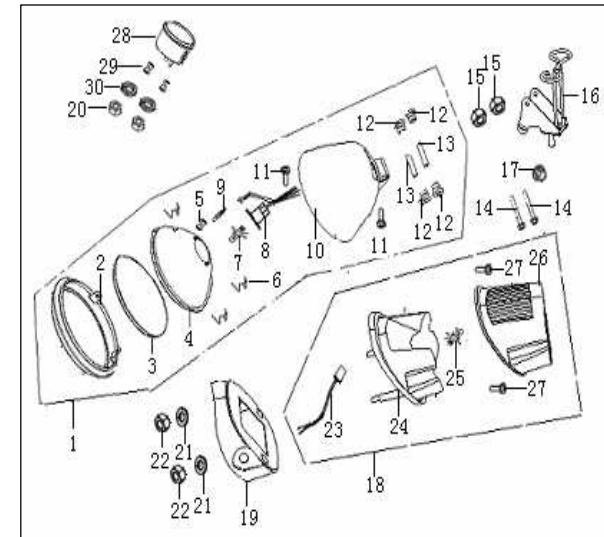

# CRUISER 250

## F20 ELECTRIC II

NO	CODE	EN DESCRIPTION	QTY	NOTES
1	96100J00P000	BATTERY 12N9-4B 12V,9AH	1	
2	98801N04FN04	RECTIFIER	1	
3	96400N0LP00A	FLASHER	1	
4	96700N0LP000	RELAY, KICK STARTER	1	
5	95000N0HP00A	HORN ASSY.	1	
6	96810N0HP000	FUSE	1	
7	96200N0HP000	COIL ASSY.,IGNITION	2	
8	97701N04FN04	C.D.I	1	
9	88000N0LP000	LOCK ASSY	1	
	88000N0LP00A	LOCK ASSY	1	PROVA DE ÁGUA
10	96800N0HP000	FUSE COMP.	1	
11	B04070600054	NUT 6 MM	1	
12	B02010601023	SCREW 6X10MM	2	
13	91900N0LP000	SWITCH	1	
14	92000N0LP00A	HARNESS, WIRING	1	
	92000N0LP001	HARNESS, WIRING	1	PROVA DE ÁGUA
15	B02000502024	SCREW 5X20MM	2	
16	B07000000504	WASHER 5MM	4	
17	B07030000504	WASHER 5MM	4	
18	B01090601664	BOLT 6X12MM	2	
19	B02050501565	SCREW M5X15	2	
20	B01090601664	BOLT 6X16MM	2	
21	B01090601264	BOLT 6X12MM	4	
22	B01090601664	BOLT 6X20MM	1	
23	65816N0HP000	CASE, BATTERY	1	
24	96002N0LP000	BAND 200MM	5	
25	96004N0HP000	BAND , BATTERY CASE	1	
26	96900N0HP000	WIRE, EARTH	1	
27	92900N0HP000	WIRE, MOTOR	1	
28	B07000000605	WASHER 6MM	2	
29	B07030000505	WASHER 5MM	2	
30	B02000502524	SCREW 5X25MM	2	
31	B04070600064	NUT 6MM	3	
32	B04000600063	NUT 6MM	2	
33	B07000000603	WASHER 6MM	2	
34	B07030000603	WASHER 6MM	2	
35	97291N0HP000	FIXING PLATE, ALARM SYSTEM	1	
36	97900B030000	THERMOSTAT	1	
37	95700N0HP000	ALARM SYSTEM ASSY	1	
38	97600N0HP000	HORN ALARM SYSTEM	1	
39	B05074001205	SCREW 4X12MM	2	

2006  
2007-2008

2006  
2007-2008

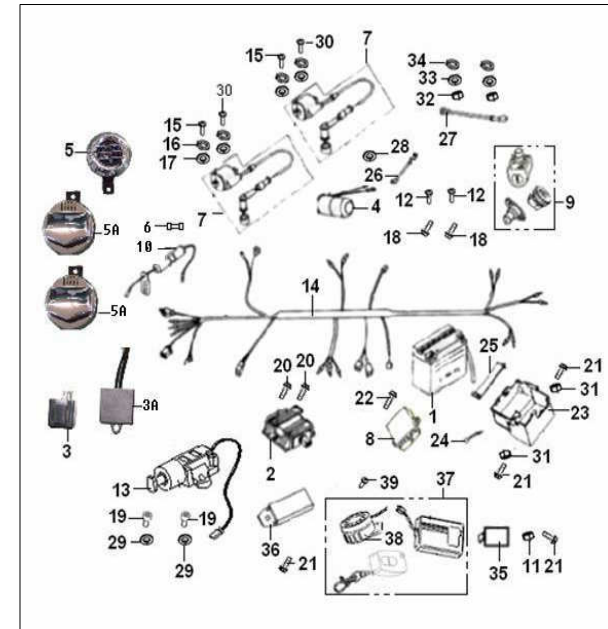

## CRUISER 250

### F21

NO	CODE	EN DESCRIPTION	QTY	NOTES
1	81500N0LP000	TURN SIGNAL, RR., L.	1	
2	81100N0LP000	TURN SIGNAL, FR., L.	1	
3	81700N0LP000	TURN SIGNAL, RR.,R	1	
4	81300N0LP000	TURN SIGNAL, FR., R.	1	
5	B05070404523	SCREW 4X45MM	8	
6	81503N0HP000	COVER, TURN SIGNAL, RR.,L	1	
7	B24012120000	BULB,12V/10W	4	
8	81105N0HP000	BOWL REPER CUSSION TURN SIGNAL	4	
9	81703N0HP000	COVER, TURN SIGNAL, RR.,R	1	
10	81103N0HP000	COVER, TURN SIGNAL, FR., L.	1	
11	B07000001003	WASHER 10MM	2	
12	B04001000063	NUT 10MM	2	
13	81303N0HP000	COVER, TURN SIGNAL, FR., R.	1	

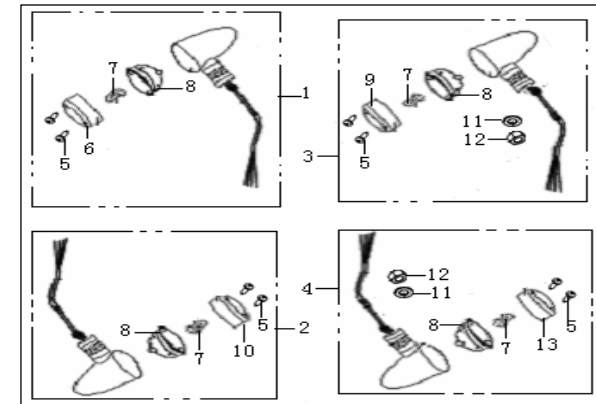

### F22 TOOL KIT

NO	CODE	EN DESCRIPTION	QTY	NOTES
1	02110G0BP000	TOOL BAG	1	
2	02104G00P000	HANDLE	1	
3	02101N0HP000	SOCKET, SPARK PLUG	1	
4	02103G00P000	SCREW DRIVER, DOUBLE-HEADED	1	
5	02102G00P000	SPANNER, SPARK PLUG	1	
6	B20011401703	WRENCH, DOUBLE-HEADED 14-17	1	
7	B20011301603	WRENCH, DOUBLE-HEADED 13-16	1	
8	B20011001203	WRENCH, DOUBLE-HEADED 10-12	1	
9	B200208000R3	SOCKET WRENCH 8	1	
10	B200206000R3	SOCKET WRENCH 6	1	
11	B200205000R3	SOCKET WRENCH 5	1	

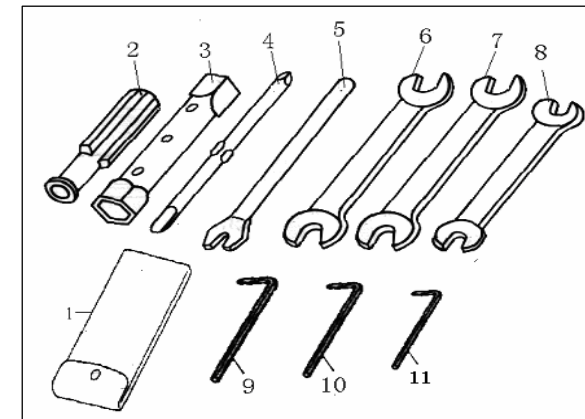

### F23 STICKER

NO	CODE	EN DESCRIPTION	QTY	NOTES
1,01	57001N0LP002	PLATE, LABEL	1	
2	B10000300602	RIVET 3X6MM	2	



## CRUISER 250

### E01 COUNTERSHAFT ASSY

NO	CODE	EN DESCRIPTION	QTY	NOTES
1	B08010002000	CIRCLIP 20	1	
2	17307N04F000	WASHER	1	
3	17306N04F000	BUSH	1	
4	17305N04F000	GEAR, 1st driven	1	
5	17312N04F000	GEAR, 4st driven	1	
6	B08010002500	CIRCLIP	1	
7	17310N04F000	WASHER	2	
8	17311N04F000	GEAR, 3rd driven	1	
9	17346N04F000	CIRCLIP	2	
10	17320N04F000	GEAR, 5th driven	1	
11	17348N04F000	WASHER	1	
12	17309N04F000	GEAR, 2nd driven	1	
13	17347N04F000	SLIP WAHER 2	1	
14	17303N04F000	SHAFT,DRIVEN	1	
15	17340N04F000	SPROCKET ASSY	1	
16	17344N04F940	WASHER, lock	1	
17	B01010601063	BOLT M6x10	2	
18	209102.014000	DRIVEN SHAFT,ASSY	1	

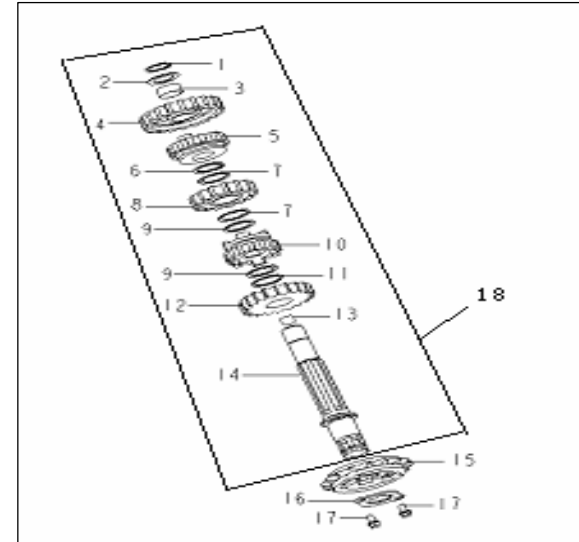

### E02 CLUTCH ASSY

NO	CODE	EN DESCRIPTION	QTY	NOTES
1	207110.001472	JOY STICK	1	
2	24904N04F920	TWIST SPRING	1	
3	24908N04F000	HANDSPIKE	1	
4	24400N04F000	HUB, primary drive	1	
5	B06010290000	BALL 11/32	1	
6	24616N04F000	WASHER, spline	1	
7	24500N04F000	HUB, clutch sleeve	1	
8	24611N04F930	SPRING	4	
9	24708N04F000	PRESSURE PLATE	4	
10	24705N04F000	PLATE FRICTION ( II )	5	
11	24503N04F000	HUBSEAT	1	
12	24615N04F930	STOP WASHER	1	
13	24505N04F000	WASHER	1	
14	24607N04F930	NUT M16X1.6	1	
15	24651N04F930	HANDSPIKE,Seat	1	
16	24914N04F930	HANDSPIKE	1	
17	24507N04F000	BOLT (M6x20)	4	
18	B07030000600	FLAT WASHER 6	1	
19	B04040000052	NUT 6	1	
20	24652J03F000	SCREW	1	
21	24000N04F000	CLUTCH ASSY	1	

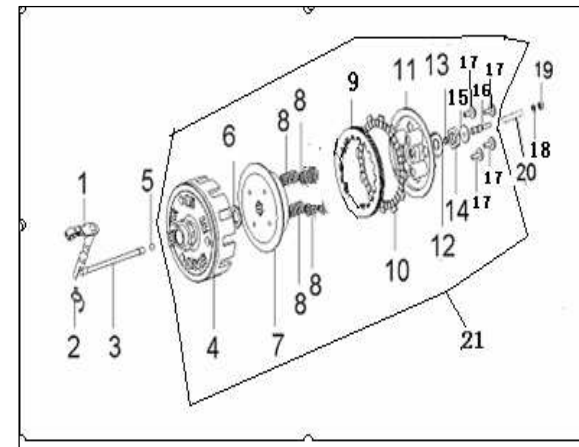

## CRUISER 250

### E03 MAGNETO ASSY

NO	CODE	EN DESCRIPTION	QTY	NOTES
1	34301N04F000	FLY WHEEL ASSY	1	
2	299035040000	COIL ASSY STATOR	1	
3	223100.008000	MAGNETO ASSY COMP.	1	

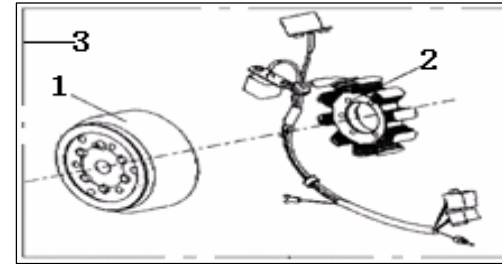

### E04 CARBURETOR ASSY

NO	CODE	EN DESCRIPTION	QTY	NOTES
1	32508N04F000	NEEDLE JET	1	
2	32506N04F000	PISTON Valve	1	
3	32618N04F000	Idle Jet (50# )	1	
4	224202.054000	Main Jet (102.5#)	1	
5	32701N04F000	GASKET,float chamber	1	
6	32622N04F000	FLOAT	1	
7	32621N04F000	FLOAT PIN	1	
8	224100.118000	CARBURATOR ASSY	1	
9	224260.002000	ELEMENT PREHEATING	1	
10	32801B09F000	WASHER	1	
11	224131.001000	ACCELERATOR ASSY.	1	
12	32719N04F000	SEAL CABLE,ACCELERATOR PUMP	1	

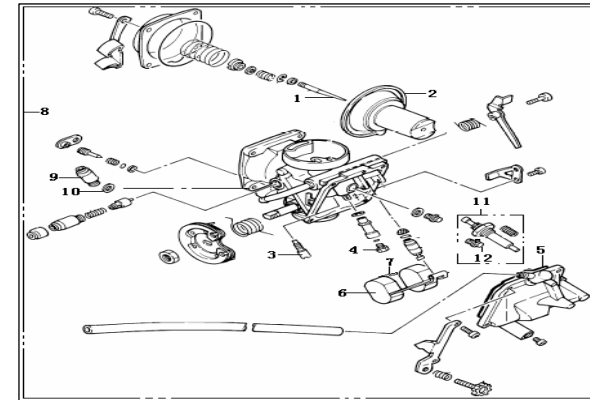



## CRUISER 250

### E05 OIL PUMP ASSY

NO	CODE	EN DESCRIPTION	QTY	NOTES
1	219100.040000	ASSY.OIL PUMP	1	
2	B02040601063	SCREW ( M6X10 )	1	
3	19301N04F910	PLATE	1	
4	19302N04F930	SPRING	1	
5	19303N04F000	VALVE,decompress	1	
6	19000N04F000	OIL PUMP ASSY	1	
7	260055040000	O SEAL RING	1	
8	B02010602523	SCREW 6X25	1	

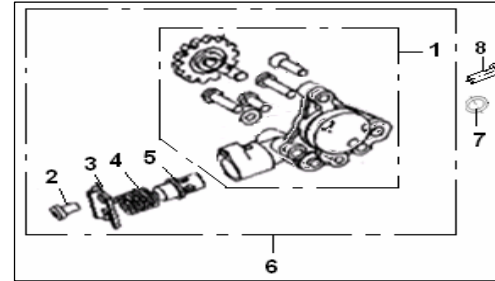

### E06 CARBURETOR INTAKE PIPE ASSY.

NO	CODE	EN DESCRIPTION	QTY	NOTES
1	32200N04F000	PIPE ASSY,intake	1	
2	32209N04F000	O RING	2	
3	B01070602064	SCREW M6X20	4	
4	202104.005472	CLAMP ASSY	1	

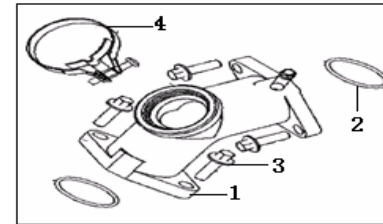

### E07 INTAKE & EXHAUST MECHANISM

NO	CODE	EN DESCRIPTION	QTY	NOTES
1	30201N04F000	VALVE,exhaust	2	
2	30106N04F000	GASKET, valve spring	4	
3	30101N04F930	SPRING, valve	4	
4	30105N04F000	RETAINER, valve spring	4	
5	30108N04F000	COTTER, valve	8	
6	30123N04F000	ARM, valve rocker	4	
7	30121N04F000	SHAFT, valve rocker	4	
8	30302H03F000	SCREW, adjusting	4	
9	30303H03F000	NUT, adjusting	4	
10	30401N04F000	CAMSHAFT(□)	1	
11	30424N04F000	CAMSHAFT(□)	1	
12	30103N04F000	VALVE, intake	2	
13	30423N04F000	SEAT, camshaft	2	
14	30417N04F000	PLATE, camshaft	2	
15	B02040601262	SCREW M6X12	2	

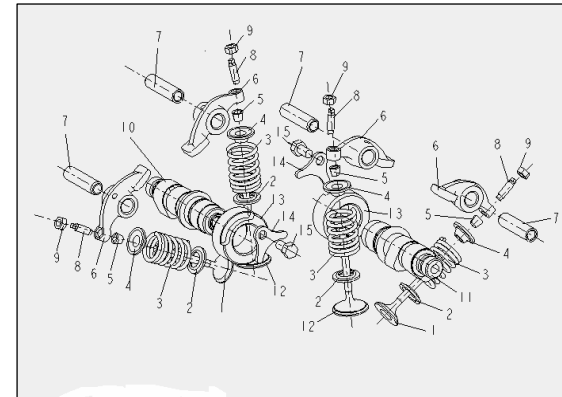

# CRUISER 250

## E08 STARTING CLUTCH ASSY

NO	CODE	EN DESCRIPTION	QTY	NOTES
1	218100.015082	Starting motor assy.	1	
2	34146N04F000	Shaft,starting idle gear	1	
3	34140N04F000	Starting idle gear comp.	1	
4	B02040801862	SCREW M8X18	3	
5	B02040602562	SCREW M6X25	2	
6	34150N04F000	Starting gearwheel comp.	1	
7	34400N04F000	Starting clutch	1	
8	217100.018082	Starting clutch assy.	1	

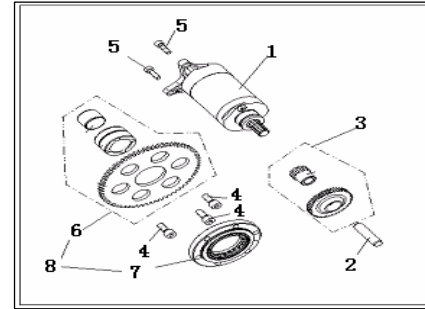

## E09 FRONT CYLINDER HEAD ASSY

NO	CODE	EN DESCRIPTION	QTY	NOTES
1	201301.004082	RIGHT COVER, cylinder head	1	
2	30505N04F000	O RING ( 82.5×3 )	1	
3	B01070611064	SCREW ( M6X110 )	2	
4	30503N04F000	GASKET, head cover	1	
5	201216.001472	STUD BOLT ( 6×43 )	2	
6	30240N04F000	SEAL COMP, valve	2	
7	30116N04F000	O RING ( 45X3 )	2	
8	201326.003082	OBSERVE COVER	2	
9	30112N04F940	WASHER	4	
10	B01070602064	SCREW ( M6X20 )	4	
11	30534N04F910	CONDUIT	4	
12	30111N04F000	GASKET, seal	4	
13	B01070602564	SCREW ( M6X25 )	2	
14	201300.018082	HEAD COVER COMP	2	
15	299075040001	SPARK PLUG	1	CR6HSA
16	30320N04F910	FIXTURE	1	
17	201313.006472	MOUNT	4	
18	30515N04F000	FLAT WASHER 20X8.5X2	1	
19	26208J01F000	PIN,POWEL	2	
20	B01070604064	SCREW ( M6X40 )	2	
21	201100.017082	CLINDER HEAD COMP	1	
22	26117J01F000	O RING ( 6.8X1.9 )	3	

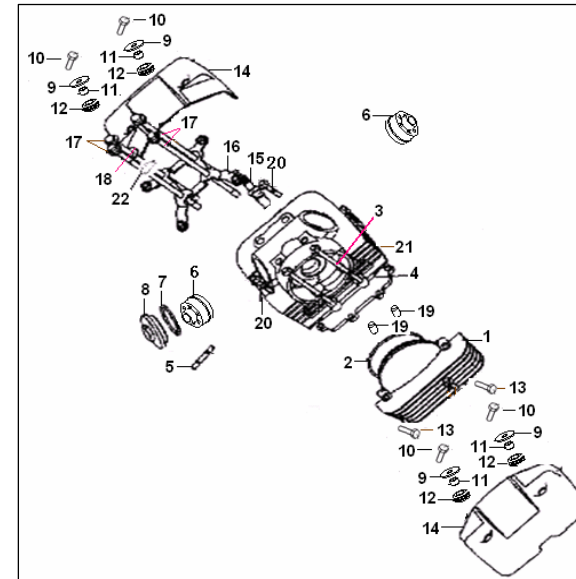

## CRUISER 250

### E10 LEFT CRANKCASE ASSY

NO	CODE	EN DESCRIPTION	QTY	NOTES
1	26123G02F000	PIN DOWEL 12X20	2	
2	26110N04F000	LEFT CRANKCASE COMP	1	
3	B01030601263	BOLT M6X12	2	
4	26113N04F000	CHAINPLATE	2	
5	307991002230	WASHER □	2	
6	26601N04F940	CLAMP □	1	
7	34800N04F000	SENCOR,neutral switch	1	
8	26603N04F940	CLAMP □	1	
9	26133N04F000	OIL SEAL I	1	
10	26143N04F000	DRAIN PLUG COMP	1	
11	26130N04F000	OIL SEAL □	1	
12	B12016630550	BEARING D305	1	
13	26129N04F000	OIL SEAL □	1	
14	B12016610350	BEARING D103	1	
15	26123N04F000	PIN,dowel	4	
16	307991002430	WASHER □	1	
17	26138N04F940	SCREW,dowel	1	
18	26137N04F000	NEEDLE BEARING ( 20X14X12 )	1	
19	26142N04F000	OILSEAL □	1	
20	B08000002800	CLIP	1	
21	26144N04F000	PLUG	1	
22	26145N04F000	WASHER	1	
23	301310608065	SCREW M6X80	4	
24	301310607065	SCREWM 6X70	2	
25	301310604065	SCREWM 6X40	1	
26	301310602565	SCREWM 6X25	4	
27	301310606365	SCREWM 6X63	2	
28	301310603065	SCREWM 6X30	2	
29	307991511651	WASHER	1	

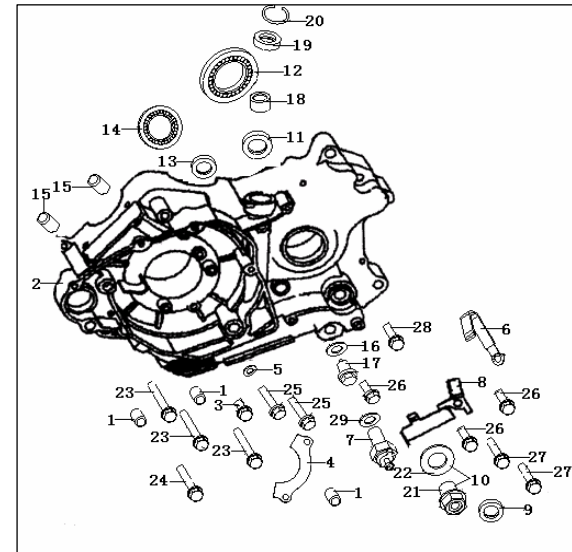

## CRUISER 250

### E11 FRONT CYLINDER ASSY

NO	CODE	EN DESCRIPTION	QTY	NOTES
1	204100.013082	CYLINDER ASSY	1	
2	27102N04F000	GASKET,cylinder	1	
3	26208J01F000	PIN,POWEL	2	

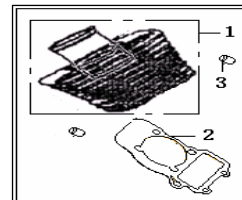

### E12 RIGHT CRANKCASE ASSY

NO	CODE	EN DESCRIPTION	QTY	NOTES
1	26401N04F940	PIPE,link	1	
2	26400N04F000	VENTILATE PIPE COMP	1	
3	201207.002472	BOLT,oil pressure indication	1	
4	26216N04F940	WASHER □	1	
5	26208N04F930	PIN	1	
6	B12016620550	BEARING D205	1	
7	B12016610450	BEARING D104	1	
8	26228N04F000	PLUG,oil limiting	1	
9	26321N04F000	OIL PIPE,soak oil	1	
10	26305N04F930	SPRING	1	
11	26307N04F000	O RING □	1	
12	206211.004082	DRAIN PLUG	1	
13	26300N03F000	FILTER WEB	1	
14	26210N04F000	RIGHT CRANKCASE COMP	1	
15	26113N04F000	CHAIN PLATE	1	
16	26207N04F000	BOLT	1	

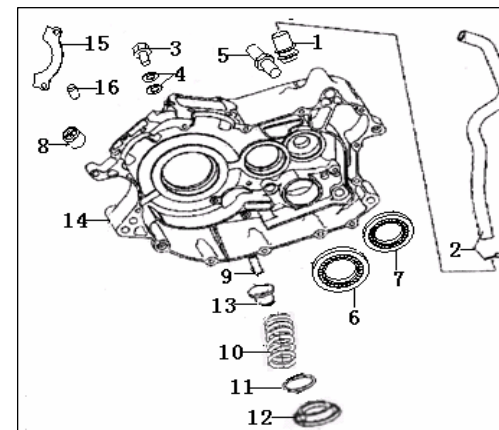

## CRUISER 250

### E13 CRANKSHAFT,CONNECTING ROD,PISTON ASSY

NO	CODE	EN DESCRIPTION	QTY
1	15230N04F000	LOCK NUT	1
2	15233N04F930	WASHER (20-GB710-88)	1
3	15234N04F000	WASHER (35-GB710-88)	1
4	15116N04F000	KEY	1
5	15207N04F000	GEAR	1
6	15117N04F000	PLATE, CHAIN	1
7	B12016630653	BEARING D306	1
8	15200N04F000	CRANKSHAFT COMP	1
9	208300.030062	PISTON	2
10	15105N04FF10	PIN, PISTON	2
11	15106N04F930	CIRCLIP	4
12	15120N04F000	RING ASSY.	2
13	15232N04F000	SPROCKET,C/SHAFT TIMING (I)	1
14	15238N04F000	SPROCKET,C/SHAFT TIMING (□)	1
15	15228H03F000	NUT(M12X1.2)	1
16	15209N04F920	WASHER (31X12.5X4)	1
17	15101N03F000	KEY	1
18	34122N04F000	WASHER (40X25.3X1)	1
19	B12016630653	BEARING D306	1
20	15212N04F000	CIRCLIP	3

NOTES

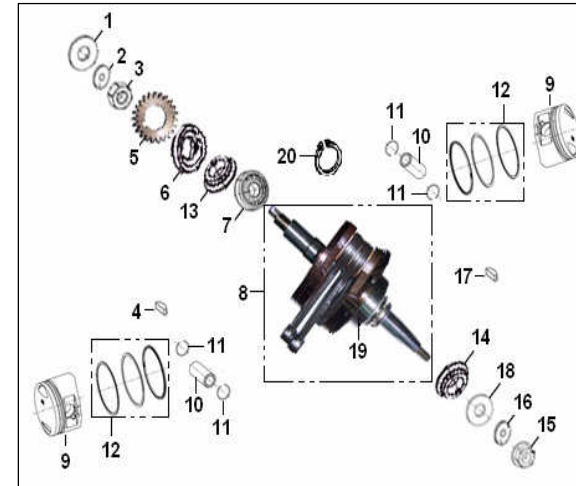

## CRUISER 250

### E14 GEAR SHIFT MECHANISM

NO	CODE	EN DESCRIPTION	QTY	NOTES
1	17701N04F000	SPRING	1	
2	17515N04F000	STOPPER ASSY	1	
3	17516N04F000	AXLE SET	1	
4	17517N04F930	WASHER	1	
5	17518N04F930	SPRING	1	
6	B08010001700	CIRCLIP 17	2	
7	17514N04F000	STOPPER	1	
8	17703N04F000	SHAFT	1	
9	17614N04F940	FORK□	1	
10	17616N04F940	FORK□	1	
11	17617N04F000	SHAFT□, shift fork	1	
12	17415N04F000	CLAW ASSY	1	
13	17417N04F000	GEAR□	1	
14	17418N04F930	SPRING	1	
15	17442N04F920	CIRCLIP	1	
16	17713N04F000	CLAW	1	
17	17600N04F000	CAM ASSY	1	
18	B02010503563	BOLT M5x35	1	
19	17601N04F000	PIN P4x29.8	1	
20	17618N04F000	PIN P4x29.8	5	
21	17624N04F000	SPRING WASHER	1	
22	17625N04F000	KICKSTAND	1	
23	17603N04F920	WASHER	2	
24	17602N04F000	PLATE	1	
25	17626N04F930	CIRCLIP	1	
26	17623N04F000	NEEDLE BEARING	1	
27	17604N04F000	CAM, gear shift	1	
28	17621N04F000	SHAFT□, shift fork	1	
29	B08010001000	CIRCLIP 10	3	
30	30300N04F000	WASHER	1	
31	19117N04F000	GEAR	1	
32	17615N04F940	FORK□	1	

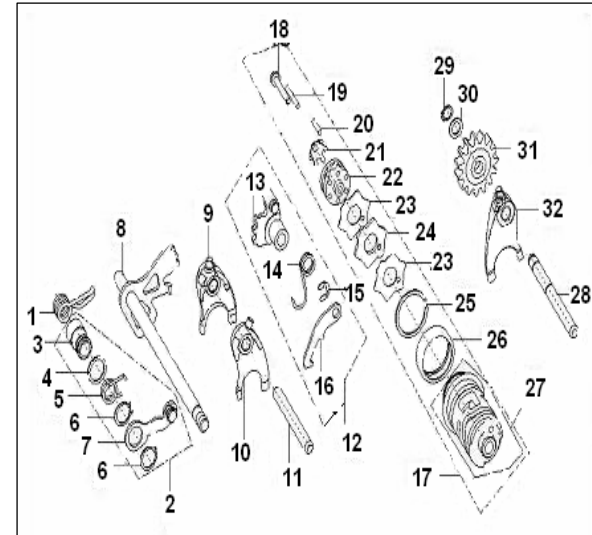

## CRUISER 250

### E15 CLUTCH COVER ASSY

NO	CODE	EN DESCRIPTION	QTY
1	301310609065	SCREW M6X90	1
2	301310603565	SCREW M6X35	4
3	301310602565	SCREW M6X25	16
4	206303.005472	BRACKET, right crankcase cover	1
5	160083090000	OIL LEVEL INDICATOR ASSY	1
6	207305.006472	PLUG	1
7	14208N04F000	O RING 20×2.2	1
8	207201.026472	COVER, sprocket	1
9	14231N04F000	PLATE	1
10	207204.006472	PLUG, cover magneto	1
11	14116H03F000	O RING 14×2.2	1
12	207205.001472	PLUG	1
13	207213.005472	PLATE	1
14	14115N04F000	O RING 30.8×3.2	1
15	B01050601064	SCREW M6X10	2
16	14230N04F000	GASKET, magneto cover	1
17	B01070607064	SCREW M6X70	1
18	207200.043472	Cover, magneto	1
19	14229N04F000	GASKET, sprccket cover	1
20	B08000002500	CIRCLIP 25	1
21	14221N04F000	OIL SEAL 14×25.5×5.5	1
22	B190106300C0	O RING 63X3.55	1
23	207300.015472	CLUTCH COVER	1
24	207308.007472	CAP, strainer (Mark "KEEWAY")	1
25	26308N04F000	STAINER	1
26	34345J01F000	SCREW	2
27	B02040603023	SCREW	3
28	30351J01F000	WASHER 6	1

NOTES

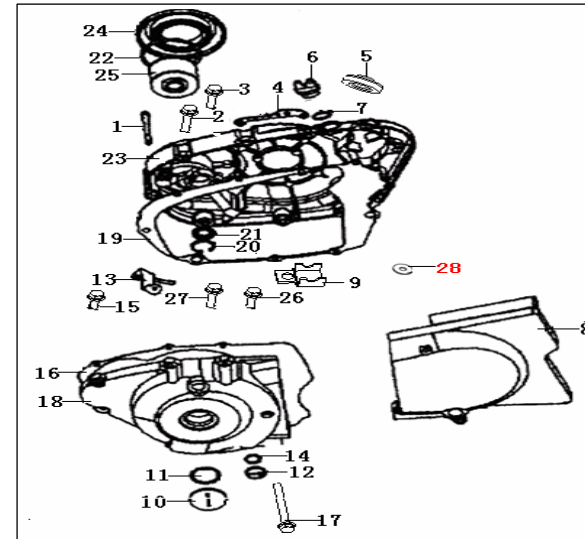

## CRUISER 250

### E16 TIMING CHAIN & TENSIONER ASSY

NO	CODE	EN DESCRIPTION	QTY
1	27450B08F000	BOLT	2
2	27302N03F000	O RING (8.5x2)	2
3	27305N03F000	SPRING ( 1 )	2
4	27304N04F000	WASHER 19.5X8.2X2	2
5	B01070601864	SCREW(M6X18)	4
6	27304N03F000	GASKET	2
7	27328N04F930	BOLT (M8X21.5)	2
8	27300N03F000	TENSIONER COMP.	2
9	27440N04F000	GUIDE CHAIN PLATE	2
10	B02030601063	BOLT(M6X12)	4
11	27430N04F000	GUIDE CHAIN PLATE	2
12	27321N04F000	TIMING CHAIN	2
13	30404N04F000	TIMING CHAIN SPROCKET BIG	2
14	205117001000	SET TENSIONER ASSY	2

NOTES

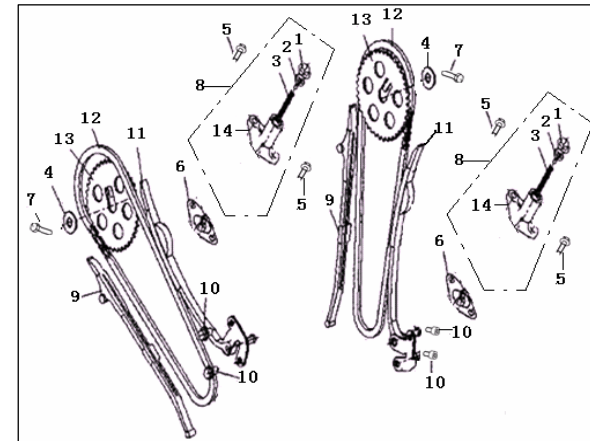

### E17 PRINCIPAL AXLE ASSY

NO	CODE	EN DESCRIPTION	QTY
1	17201N04F000	SHAFT,DRIVEN	1
2	17205N04F000	GEAR, 4th drive	1
3	17223N04F000	WASHER	1
4	17224N04F930	CIRCLIP	1
5	17204N04F000	GEAR, 3rd drive	1
6	17206N04F000	GEAR, 5th drive	1
7	17202N04F000	GEAR, 2nd drive	1
8	209101.010000	DRIVEN SHAFT ASSY	1

NOTES

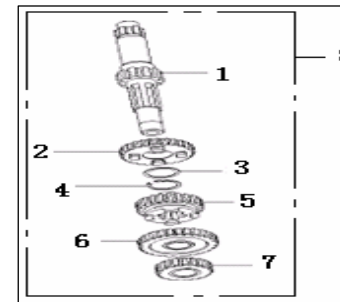



## CRUISER 250

### E18 CYLINDER HEAD ASSY

NO	CODE	EN DESCRIPTION	QTY	NOTES
1	201301.004082	RIGHT COVER, cylinder head	1	
2	30505N04F000	O RING 82.5×3	1	
3	B01070611064	SCREW M6X110	2	
4	30503N04F000	GASKET, head cover	1	
5	201216.001472	STUD BOLT 6×43	2	
6	30240N04F000	SEAL COMP, valve	2	
7	30116N04F000	O SEAL RING	2	
8	201326.003082	OBSERVE COVER	2	
9	30112N04F940	WASHER	4	
10	B01070602064	SCREW M6X20	4	
11	30534N04F910	CONDUIT	4	
12	30111N04F000	GASKET, seal	4	
13	B01070602564	SCREW M6X25	2	
14	201300.018082	HEAD COVER COMP	2	
15	299075040001	SPARK PLUG	1	
16	30320N04F910	FIXTURE	1	
17	201313.006472	MOUNT	4	
18	30515N04F000	WASHER	1	
19	26208J01F000	PIN, DOWEL	2	
20	B01070604064	SCREW M6X40	2	
21	201100.017082	CLINDER HEAD	1	
22	201105.001472	SUSPENDER COMP	1	
23	26117J01F000	O RING 6.8X1.9	3	

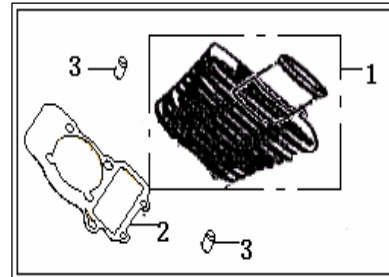
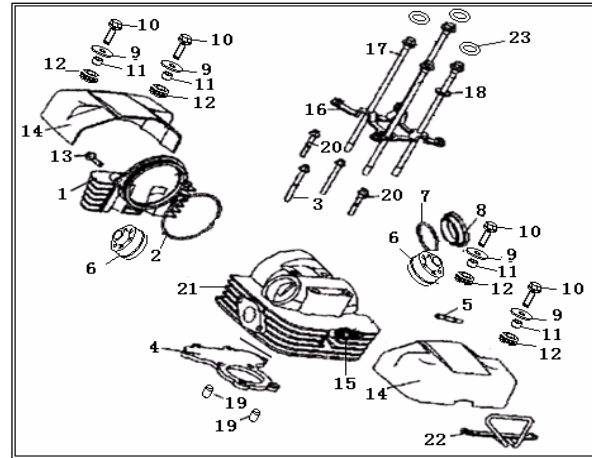

### E19 REAR CYLINDER ASSY

NO	CODE	EN DESCRIPTION	QTY	NOTES
1	204100.014082	CYLINDER MACHINING ASSY	1	
2	27102N04F000	GASKET, cylinder	1	
3	26208J01F000	PIN, POWEL	2	