

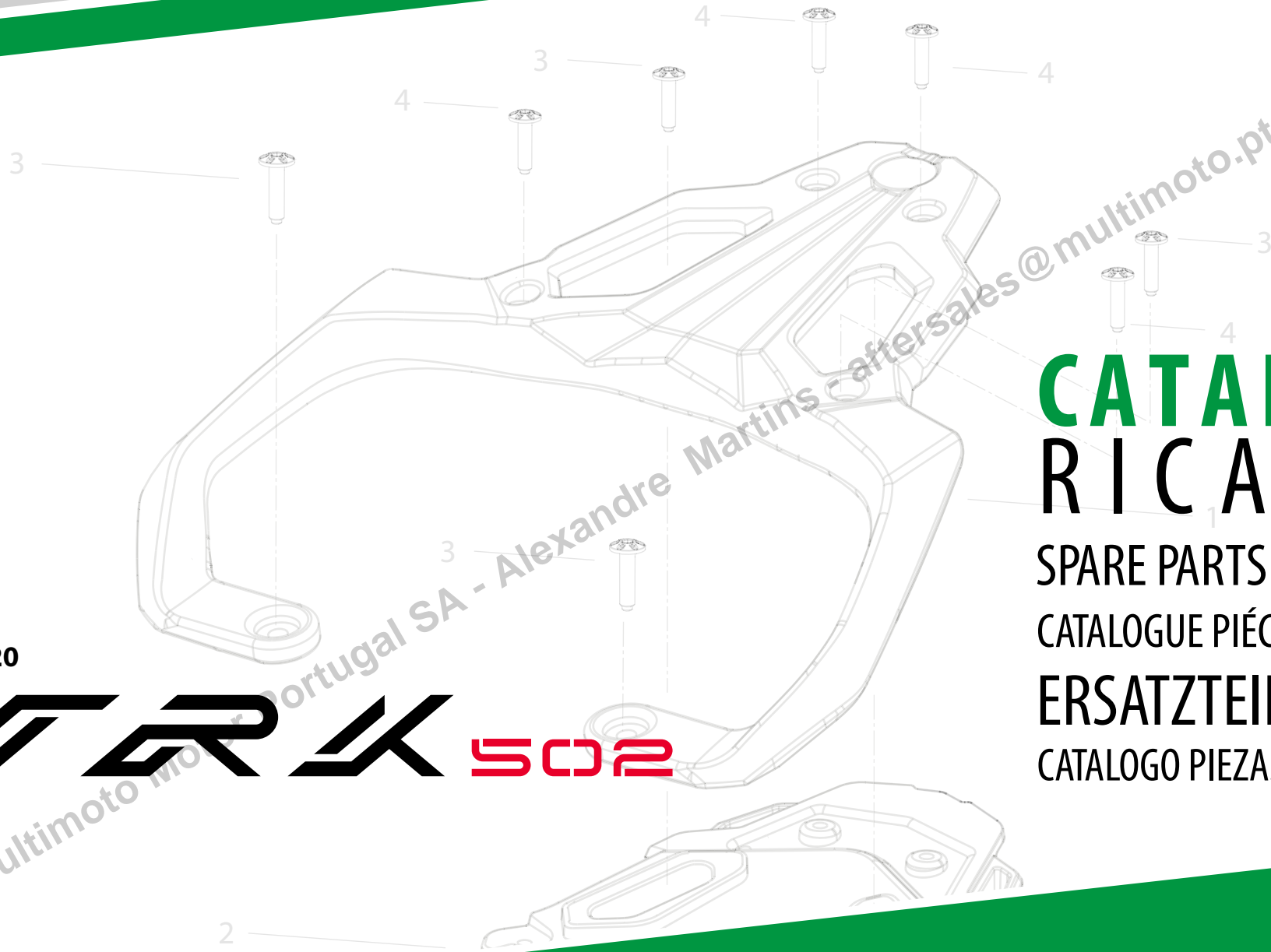

Benelli



MY 2020

TRK 502

CATALOGO RICAMBI

SPARE PARTS CATALOGUE
CATALOGUE PIÉCES DETACHEES
ERSATZTEILKATALOG
CATALOGO PIEZAS DE REPUESTO



QUESTO CATALOGO SERVE PER RICHIEDERE CON ESATTEZZA LE PARTI DI RICAMBIO.

THE PRESENT SPARE PARTS ORDER EXACTLY THE RIGHT SPARE PARTS.

CE CATALOGUE PERMET DE COMMANDER CORRECTEMENTE LES PIÈCES DETACHEES.

DIESER ERSATZTEILKATALOG DIEN T ZUR GENAUEN ANGABE DER TEILE BEI ERSATZTEILBESTELLUNGEN.

EL PRESENTE CATÁLOGO SIRVE PARA PEDIR CON EXACTITUD LAS PARTES DE REPUESTO.

NELLE ORDINAZIONI INDICARE:IL NUMERO DEI CODICI DEI PARTICOLARI SEGUITO DALLA DESCRIZIONE E LA QUANTITÀ DESIDERATA.

WHEN ORDERING SPECIFY:THE PART'S CODE NUMBER FOLLOWED BY ITS DESCRIPTION AND QUANTITY NEEDED.

LES COMMANDES DOIVENT ÊTRE PASSÉES EN INDIQUANT:LE NUMERO DE CODE DES PIÈCES DÉTACHÉES SUIVI DE LEUR DESCRIPTION ET QUANTITÉ DÈSIRÉE.

BEIERSATZBESTELLUNG IST FOLGENDES ANZUGEBEN:DIE BESTELLNUMMER DER ERSATZTEILE MIT DER ENTSPRECHENDEN BESCHREIBUNG UND GENAUE MENGE.

EN LOS PEDIDOS SE DEBE INDICAR:EL NÚMERO DE CÓDIGO DE LA PARTE Y A CONTINUACIÓN LA DESCRIPCIÓN Y CANTIDAD DESEADA.

LE INDICAZIONI CON LE FRECCHE SI RIFERISCONO AI LATI DEL VEICOLO RISPETTO AL SENSO DI MARCIA.

REFERENCE WITH ARROWS APPLY TO THE VEHICLE IN TERMS OF ITS DIRECTION OF MOVEMENT.

RÉFÉRENCE AVEC DES FLÈCHES SONT LES CÔTÉS DU VÉHICULE PAR RAPPORT AU SENS DE LA MARCHÉ.

DIE ANGABEN MIT PFEILE BEZIEHEN SICH AUF DAS FAHRZEUG IN FAHRRICHTUNG.

LAS INDICACIONES CON LAS FLECHAS SE REFIEREN A LOS LADOS DEL VEHÍCULO RESPECTO DEL SENTIDO DE MARCHA.

I DISEGNI DELLE PARTI DI RICAMBIO SONO SOLO INDICATIVI E NON RAPPRESENTANO IL PEZZO IN OGGETTO.

SPARE PARTS DRAWINGS ARE GENERAL AND DO NOT REPRESENT THE PART.

LES PLANS DES PIÈCES DÉTACHÉES SONT FOURNIS SEULEMENT À TITRE INDICATIF ET NE REPRÉSENTENT PAS LA PIÈCE CONCERNÉE.

DIE ZEICHNUNGEN DER ERSATZTEILE SIND NUR ALS HINWEISE GEDACHT UND STELLEN NICHT DAS BETROFFENE TEIL DAR.

LOS DISEÑOS DE LAS PARTES DE RECAMBIO SON SOLO INDICATIVOS Y NO REPRESENTAN LA PIEZA EN CUESTIÓN.

I DATI CONTENUTI IN QUESTO CATALOGO SONO INDICATIVI E POSSONO ESSERE SOGGETTI A MODIFICHE SENZA IMPEGNO DI PREAVVISO.

THE CONTENTS OF THIS CATALOGUE ARE GENERAL AND CAN UNDERGO CHANGES WITHOUT PRIOR NOTICE.

LES DONNÉES DE CE CATALOGUE SONT CITÉES SEULEMENT À TITRE INDICATIF ET PEUVENT ÊTRE L'OBJET DE MODIFICATIONS SANS AVIS PRÉALABLE.

BEI DEN IM KATALOG ANGEFÜHRTEN DATEN HANDELT ES SICH UM ANHALTSDATEN, DIE JEDERZEIT, OHNE VORANKÜNDIGUNG, GEÄNDERT WERDEN KÖNNEN.

LOS DATOS CONTENIDOS EN EL PRESENTE CATÁLOGO SON INDICATIVOS Y PUEDEN MODIFICARSE SIN AVISO PREVIO.

PAG.	TAVOLA	CONTENTS	SOMMAIRE	INHALTSANGABE	INDICE
5	00A	EQUIPMENT	EQUIPEMENT	AUSSTATTUNG	EQUIPAMIENTO
7	0AA	SPECIAL TOOLS	OUTILS SPECIAUX	SONDERWERKZEUGE	HERRAMENTAL ESPECIALES
9	00B	COMPLETE ENGINE	MOTEUR COMPLET	KOMPLETTE MOTOR	MOTOR COMPLETO
11	001	TIMING	DISTRIBUTION	VENTILSTEUERUNG	DISTRIBUCIÓN
13	002	CYLINDER HEAD	GROUPE CULASSE	ZYLINDERKOPFGRUPPE	GRUPO CABEZA
16	003	CRANK GEAR ASSEMBLY	ENSEMBLE BIELLISME	KURBELGETRIEBE KOMPLETTE	JUNTO CINEMETISMO
19	004	FLYWHEEL	VOLANT	SCHWUNGRAD	VOLANTE
21	005	HALF CRANKCASES	DEMI-CARTERS	GEHÄUSEHÄLTE	PARAJA SEMI-CARTER
24	006	L.H. ENGINE COVER	COUVERCLE MOTEUR GAUCHE	LINKER DECKEL MOTOR	TAPA MOTOR IZQUIERDO
26	007	R.H. ENGINE COVERS	COUVERCLES MOTEUR DROITE	RECHTE DECKEL MOTOR 2	TAPAS MOTOR DERECHO
28	008	WATER PUMP	POMPE EAU	WASSERPUMPE	BOMBA AGUA
30	009	CLUTCH	EMBRAYAGE	KUPPLUNG	EMBRAGUE
32	010	GEAR-BOX	BOÎTE A VITESSES	SCHALTUNG	CAMBIO
35	011	THROTTLE BODY	CORPS À PAPILLON	DROSSELKÖRPER	CUERPO MARIPOSA
39	012	LUBRIFICATION	LUBRIFICATION	SCHMERUNG	LUBRICACIÓN
41	013	FRONT FORK	FOURCHE AVANT	TELEGABEL	HORQUILLA DELANTERA
44	014	FRONT WHEEL	ROUE AVANT	VORDERRAD	RUEDA DELANTERA
46	015	REAR WHEEL	ROUE ARRIÈRE	HINTERRAD	RUEDA TRASERA
48	016	EXHAUST SYSTEM	ECHAPPEMENT	AUSPUFFANLAGE	GRUPO ESCAPE
50	017	INTAKE	ASPIRATION	LUFTEINZUG	ASPIRACIÓN
52	018	FUEL TANK	RÉSEVOIR CARBURANT	KRAFTSTOFFTANK	DEPÓSITO GASOLINA
55	019	FRONT FAIRING	CARÉNAGE AVANT	VORDERSHALE	CARENADO DELANTERO
57	020	MAIN FAIRINGS	CARÉNAGES CENTRALE	SCHALE MAINSEITE	BASTIDOR CENTRAL
60	021	SIDE FAIRING	CARENE LATÉRAL	VERKLEIDUNGS SEITLICH	CARROCERIA LATERAL
63	022	SWINGARM	FOURCHE	SCHWINGE	BASCULANTE
66	023	FRONT/REAR BRAKE	FREIN AVANT ET ARRIERE	VORD/HINTER BREMSE	FRENO DELANTERO Y TRASERO
69	024	COOLING CIRCUIT	CIRCUIT DE REFROIDISSEMENT	KÜHLREISLAUF	CIRCUITO REFRIGERADOR
72	025	FRAME	CADRE	RAHMEN	CHASIS
75	026	FRONT FOOTPEG	REPOSE PIEDS AVANT	VORDERE FUSSRASTE	ESTRIBERAS DELANTERA
78	027	REAR FOOT PEG	REPOSE PIED ARRIERE	HINTERE FUSSRASTE	ESTRIBERAS TRASERA
80	028	STAND	BEQUILLE	BOCK	CABALLETTE
82	029	HANDLEBAR AND CONTROLS	GUIDON ET COMANDES	LENKER UND STEUERORGANE	MANILLAR Y MANDOS
85	030	HEADLIGHT FAIRING	CARÉNAGE	FAHRTWINDSCHUTZ	CÚPULA



87	031	CODONE	TAIL GUARD	CORPS DE SELLE	HECK	CUERPO ASIENTO
90	032	PORTATARGA	NUMBER PLATE HOLDER	PORTE-PLAQUE	NUMMERSCHILDTAFEL	PORTA-MATRÍCULA
92	033	FANALI E STRUMENTAZIONE	HEAD-LIGHTS AND INSTRUMENTATION	PHARES ET INSTRUMENTATION	SCHEINWERFERS UND INSTRUMENTENAUSRÜSTUNG	FAROS Y INSTRUMENTACIÓN
94	034	PARAFANGO ANTERIORE	FRONT MUDGUARD	GARDE-BOUE AVANT	VORDERES SCHUTZBLECH	GUARDABARROS DELANTERA
96	035	IMPIANTO ELETTRICO	ELETRIC SYSTEM	INSTALLATION ELECTRIQUE	ELEKTRISCHE ANALAGE	SISTEMA ELECTRICO
99	036	MANIGLIONE POSTERIORE	REAR HANDLE	POIGNÉE ARRIÈRE	GRIFF HINTEN	MANIJA TRASERO
101	037	GRAFICHE PER MODELLO BIANCO	STICKERS FOR WHITE MODEL	DÉCALCOMANIE POUR MODELE BLANC	ABZIEHBILD FÜR WEISS MODELL	ADHESIVO PARA EL MODELO BLANCO
103	038	GRAFICHE	STICKERS	DÉCALCOMANIE	ABZIEHBILD	ADHESIVO



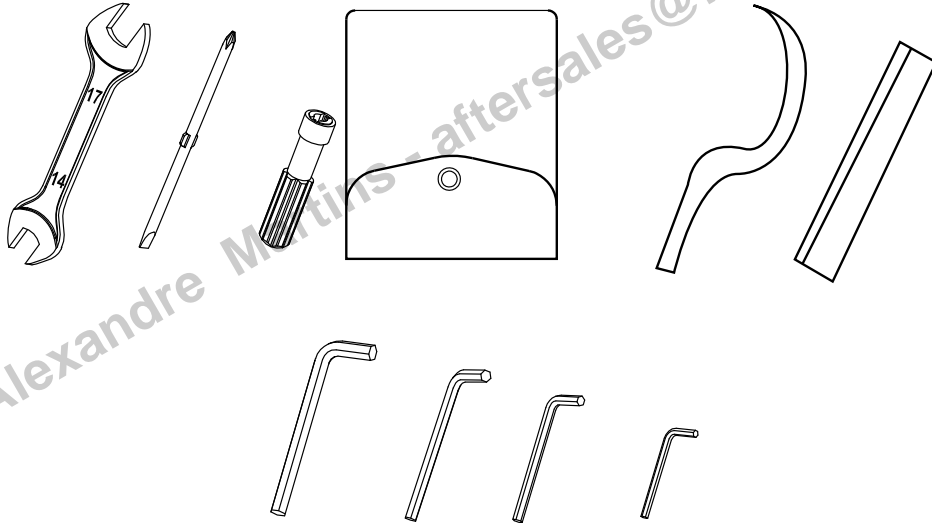
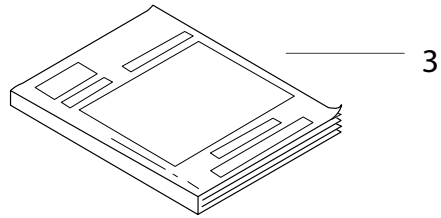
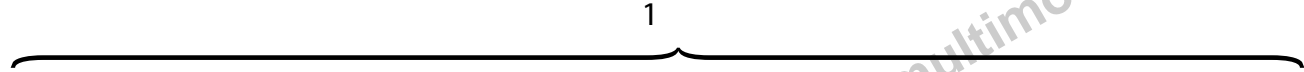
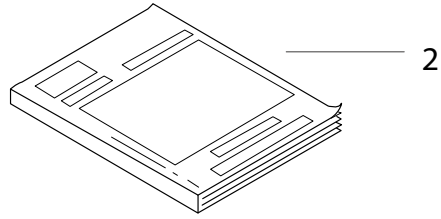

POS. NO. N. INDEX POS.	N. CODICE CODE NO. Nr. CODE ATRÍKEL Nr. CODICO Nr.	DESCRIZIONE	DESCRIPTION	DESIGNATION	BEZEICHNUNG	DENOMINACION	NOTE NOTES NOTES MARKE NOTAS	Q.TA' CONF. Q.TY PACK. Q.TE EMB. M.GE PAK. C.AD PAQ.	
1	02100P250004	TROUSSE ATTREZZI COMPLETA	COMPLETE TOOLS CASE	TROUSSE OUTILS COMPLET	WERKZEUG-KASTEN KOMPLETT	CAJA DE HERRAMIENTAS COMPLETA		1	
2	02401P160005	LIBRETTO USO E MANUTENZIONE (TRK502 EU4)	OWNER'S MANUAL (TRK502 EU4)	MANUEL D'UTILISATION ET ENTRETIEN (TRK502 EU4)	ANLEITUNGS- UND WARTUNG SHEFT (TRK502 EU4)	MANUAL DE USO Y ENTRENAMIENTO (TRK502 EU4)		1	
3	0000094103002	LIBRETTO DI GARANZIA (GOLD)	WARRANTY BOOKLET (GOLD)	CARNET DE GARANTIE (GOLD)	GARANTIE (GOLD)	MANUAL DE GARANTIA (GOLD)		1	



Multimoto Motor Portugal SA - Alexandre Martins - aftersales@multimoto.pt

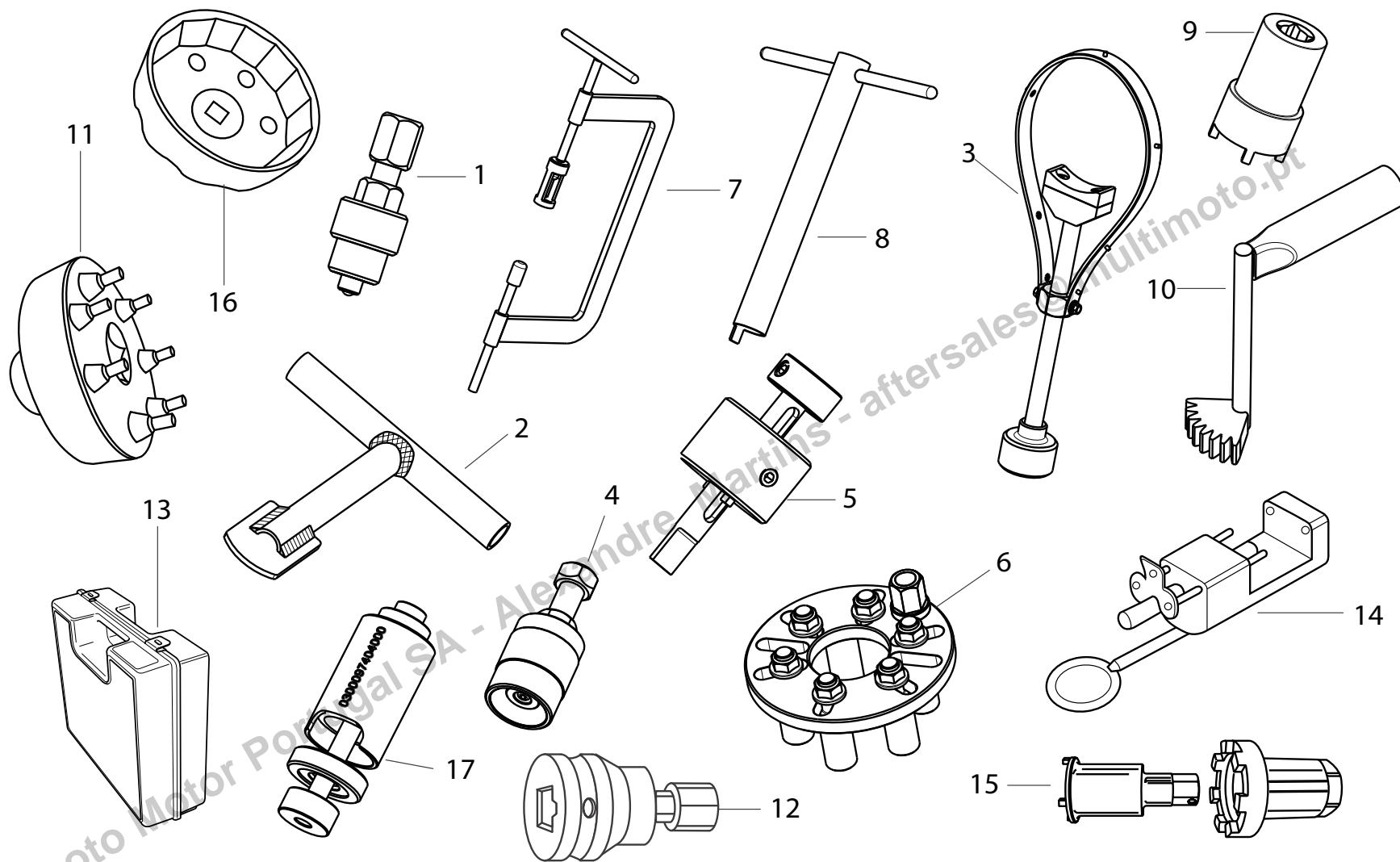

POS. NO. N. INDEX POS.	N. CODICE CODE NO. Nr. CODE ATRÍKEL Nr. CODICO Nr.	DESCRIZIONE	DESCRIPTION	DESIGNATION	BEZEICHNUNG	DENOMINACION	NOTE NOTES NOTES MARKE NOTAS	Q.TA' CONF. Q.TY PACK. Q.TE EMB. M.GE PAK. C.AD PAQ.	
1	0320097042000	ESTRATTORE COPERCHIO VOLANO	FLYWHEEL COVER EXTRACTOR	EXTRACTEUR POUR COUVERCLE VOLANT	AUSZIEHER FÜR DECKEL SCHWUNGRAD	EXTRACTOR TAPA VOLANTE		1	
2	0320097043000	CACCIAVITE COPERCHIO VOLANO	FLYWHEEL COVER SCRENDRIVER	TOURNEVIS COUVERCLE DE VOLANT	SCHRAUBENDREHER LICHTMASCHINE SCHWUNGRADABDECKUNG	DESTORNILLADOR CUBIERTA VOLANTE		1	
3	0320097044000	CHIAVE VOLANO	FLYWHEEL FIXER	CLÉ À RUBAN VOLANT D'ALTERNATEUR	BANDSCHLÜSSEL SCHWUNGRAD	CLAVE DE CINTA ENCENDIDO DEL VOLANTE		1	
4	KST03BL01055	ESTRATTORE VOLANO	FLYWHEEL PULLER	EXTRACTEUR VOLANT MAGNETIQUE	SCHWUNGRADABZIEHER	UTIL DESMANTAR VOLANTE		1	
5	KST03BL01050	ATTREZZO BLOCCAGGIO TENDICATENA	TOOL LOCK TENSIONER CHAIN	OUTIL DE VERROUILLAGE DE TENDEUR DE CHAÎNE	VERRIEGELUNGSWERKZEUG KETTENSANNER	HERRAMIENTA DE BLOQUEO DEL TENSOR DE CADENA		1	
6	0320097047000	CHIAVE CAMPANA FRIZIONE	WRENCH CLUTCH	CLÉ, NOIX D'EMBRAYAGE	SCHLÜSSEL KUPPLUNGSNABEN	CLAVE EMBRAGUE		1	
7	0320097050000	ATTREZZO MONTAGGIO VALVOLE	TOOL VALVE ASSEMBLY	OUTIL DE DÉMONTAGE ET DE RÉASSEMBLAGE DE SOUPAPES	VENTILFEDER, MONTAGE/DEMONTAGE WERKZEUG	CONJUNTO MONTAJE Y DESMONTAJE DE LA VÁLVULA		1	
8	0320097051000	ATTREZZO TENDIMOLLA SALTARELLO CAMBIO	TOOL SPRING STRECHER GEAR	OUTIL DE TENSION DE RESSORT, SÉLECTEUR DE VITESSE	WERKZEUG SPRINGSPANNER, GETRIEBE	HERRAMIENTA DE TENSION DE RESORTE, SELECTOR DE VELOCIDAD		1	
9	0320097052000	CHIAVE GHIERA CAMPANA FRIZIONE	CLUTCH CLAMPING JAW	DOUILLE CANNELÉ POUR ECROU D'EMBRAYAG	KUPPLUNG KRONENMUTTER WERKZEUG	LLAVE EXTRACTOR TUERCA DE EMBRAGUE		1	
10	R999999999999	CHIAVE BLOCCAGGIO INGRANAGGI	WRENCH LOCKING GEAR	CLÉ QUI BLOQUE LES ENGRENAGES	SCHLÜSSEL ZAHNRADSPERRE	LLAVE BLOQUE A ENGRANAJES		1	
11	KST03BL01061	CHIAVE TAPPO FORCELLA 7 PIN	FORK TOOL KEY, 7 PINS	CLÉ DE FOURCHE, 7 PINS	GABELSCHLÜSSEL, 7 PINS	7 PIN FORK LLAVE		1	
12	R300097146000	CHIAVE MONTAGGIO TESTA DI STERZO	WRENCH MOUNTING STEERING HEAD OBD	CLÉ DE TÊTE DE DIRECTION	SCHLÜSSEL FÜR MONTAGE GABELKOPF	LLAVE DEL MONTAJE DELA TIJA SUPERIOR		1	
13	A000097505000	KIT STRUMENTO DIAGNOSI OBD	KIT DIAGNOSIS INSTRUMENT OBD	KIT INSTRUMENT DE DIAGNOSTIC OBD	KIT DIAGNOSE INSTRUMENT OBD	KIT INSTRUMENTO DE LA DIAGNOSIS OBD		1	
14	R999999999999	KIT CHIUDI CATENA REGINA	REGINA, CHAIN TOOL KIT	REGINA, KIT D'OUTILS DE LA CHAÎNE	REGINA, KETTENWERKZEUGSATZ	REGINA, KIT DE HERRAMIENTAS DE CADENA		1	
15	R180297129000	CHIAVE GHIERA DI STERZO	MOUNTING STEERING RING NUT WRENCH	CLÉ DE TÊTE DE BAGUE DE DIRECTION	SCHLÜSSEL FÜR MONTAGE LENKUNGSZAPFEN	LLAVE DEL MONTAJE DEL ZUNCHO DE DIRECCIÓN		1	
16	KST03BL01031	ATTREZZO FILTRO OLIO	SPECIAL TOOLS OIL FILTER	OUTILS SPÉCIAUX FILTRE À HUILE	SONDERWERKZEUGE ÖLFILTER	FERRAM. ESPE. FILTRO DE ÓLEO		1	
17	0300097404000	ATTREZZO RIMOZIONE/INSTALLAZIONE SILENT-BLOCK	SILENT BLOCK PULLER INSTALLER	OUTIL DE DÉMONTAGE/INSTALLATION SILENT-BLOCK	SILENT-BLOCK AUS-/EINBAUWERKZEUG	HERRAMIENTA DE INSTALACIÓN/REMOCIÓN DE BLOQUES SILENCIOSOS		1	

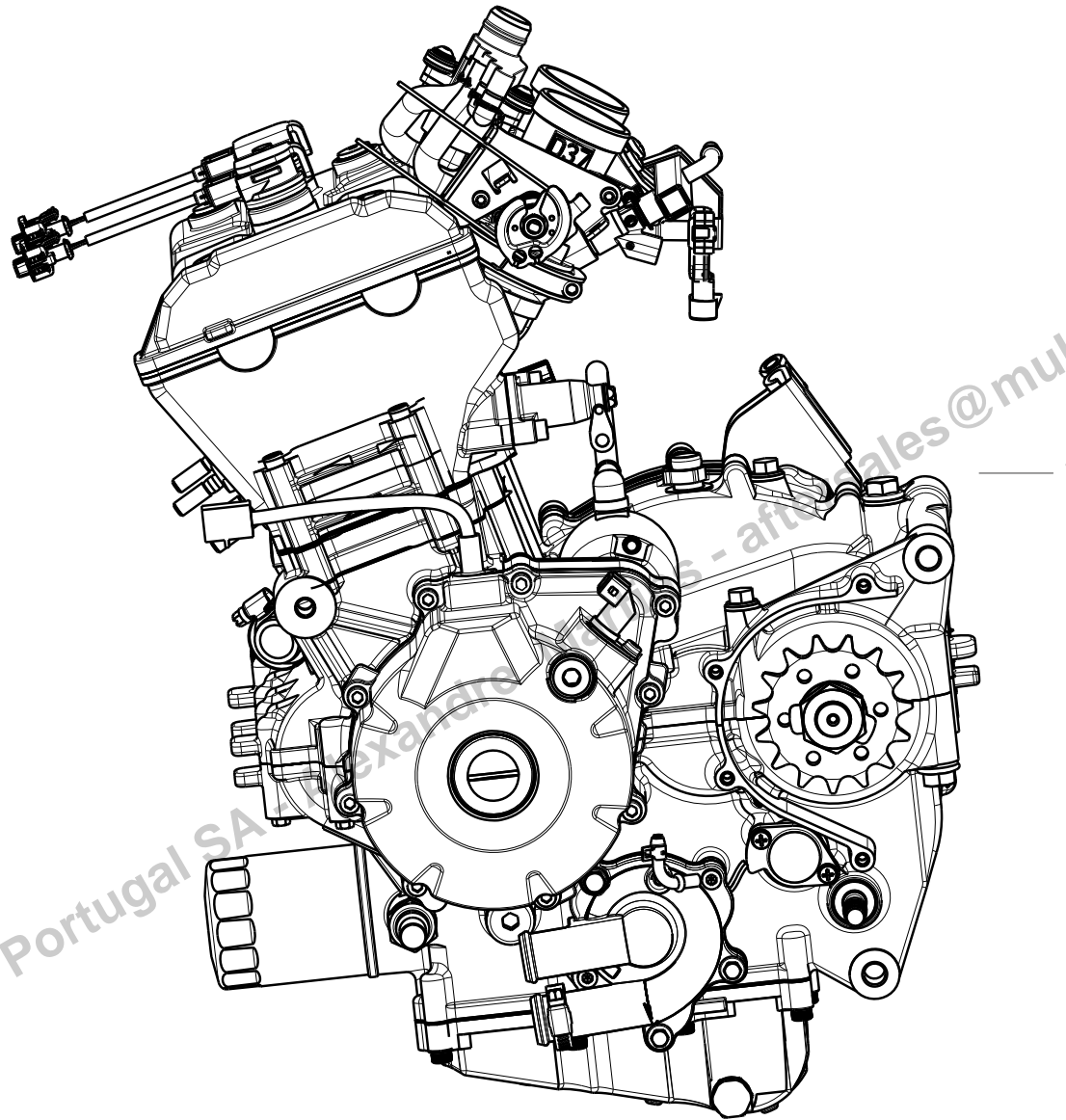



MOTORE COMPLETO



COMPLETE ENGINE



MOTEUR COMPLET



KOMPLETTE MOTOR



MOTOR COMPLETO

POS. NO. N. INDEX POS.	N. CODICE CODE NO. Nr. CODE ATRIKEL Nr. CODICO Nr.	DESCRIZIONE	DESCRIPTION	DESIGNATION	BEZEICHNUNG	DENOMINACION	NOTE NOTES NOTES MARKE NOTAS	Q.TA' CONF. Q.TY PACK. Q.TE EMB. M.GE PAK. C.AD PAQ.	
1	C2628033NB00	MOTORE COMPLETO (TRK502)	COMPLETE ENGINE (TRK502)	MOTEUR COMPLET (TRK502)	KOMPLETTE MOTOR (TRK502)	MOTOR COMPLETO (TRK502)		1	



Multimoto Motor Portugal SA - Alexandre Martins - aftersales@multimoto.pt

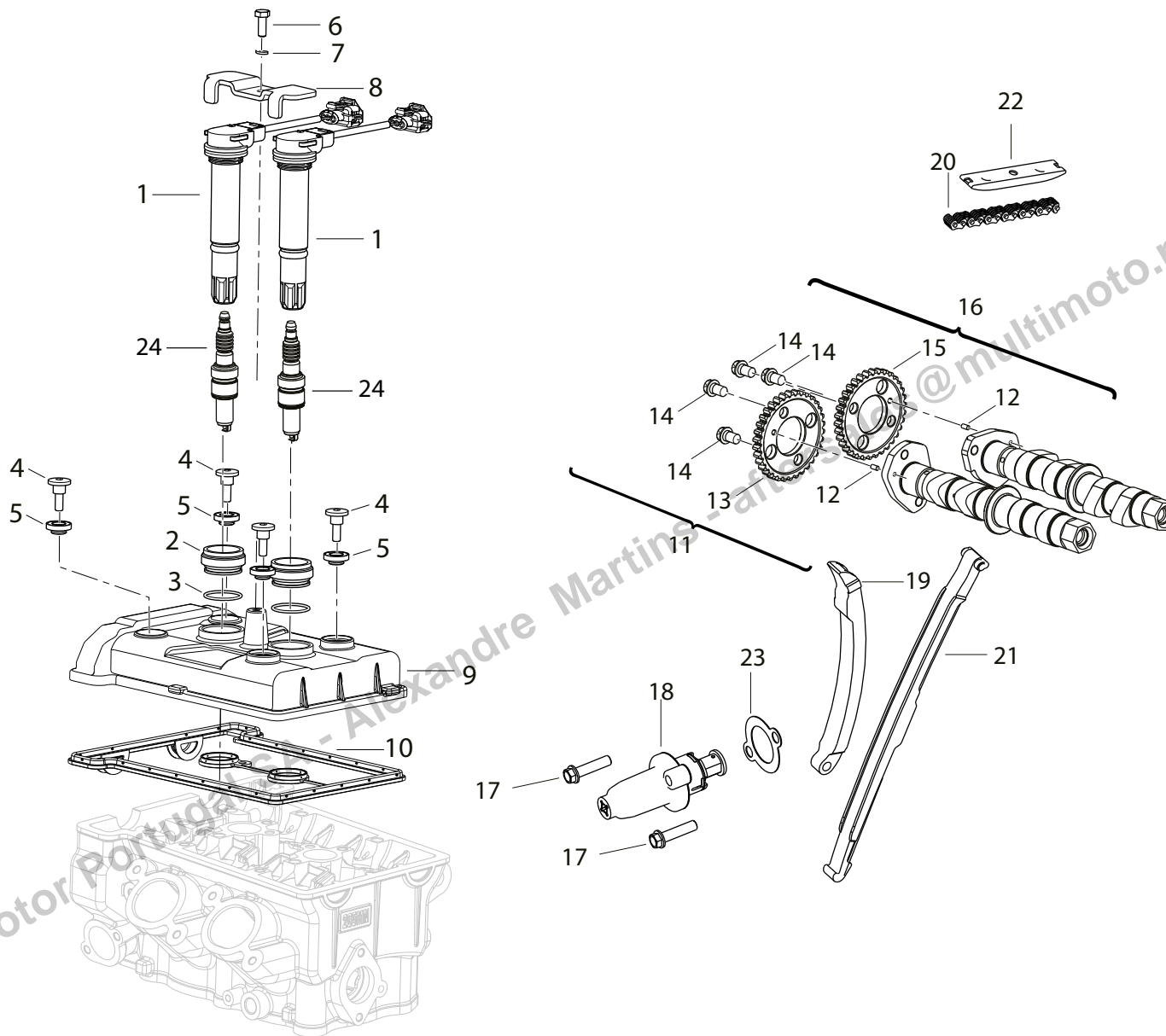

POS. NO. N. INDEX POS.	N. CODICE CODE NO. Nr. CODE ATRÍKEL Nr. CODICO Nr.	DESCRIZIONE	DESCRIPTION	DESIGNATION	BEZEICHNUNG	DENOMINACION	NOTE NOTES NOTES MARKE NOTAS	Q.TA' CONF. Q.TY PACK. Q.TE EMB. M.GE PAK. C.AD PAQ.	
1	96200P250000	BOBINA	COIL	BOBINE	ZÜNDSPULE	BOBINA		1	
2	100286030000	GOMMINO	RUBBER PAD	JOINT EN CAOUTCHOUC	GUMMISTÜCK	JUNTA DE GOMA		1	
3	B190102650B0	GUARNIZIONE O-RING	O-RING	JOINT D'ÉTANCHÉITÉ	DICHTUNG O-RING	JUNTA OR		1	
4	R320052161000	VITE	SCREW	VIS	SCHRAUBE	TORNILLO		1	
5	100066030000	GOMMINO	RUBBER PAD	JOINT EN CAOUTCHOUC	GUMMISTÜCK	JUNTA DE GOMA		1	
6	R030451014000	VITE (M6X16)	SCREW (M6X16)	VIS (M6X16)	SHARAUBE (M6X16)	TORNILLO (M6X16)		1	
7	R020051041000	RONDELLA SPECIALE	SPECIAL WASHER	RONDELLE SPÉCIALE	SPEZIALUNTERLEGSCHIBE	ARANDELA ESPECIAL		10	
8	100276220000	STAFFA	BRACKET	BRIDE	BÜGEL	SOPORTE		1	
9	10901622NB01	COPERCHIO DISTRIBUZIONE (NERO)	CAMSHAFT COVER (BLACK)	COUVERCLE D'ARBRE À CAMES (NOIR)	DECKELVERTEILER (SCHWARZ)	TAPA DEL DISTRIBUCIÓN (NEGRO)		1	
10	100146220000	GUARNIZIONE COPERCHIO DISTRIBUZIONE	TIMING COVER GASKET	GARNITURE COUVERCLE DISTRIBUTION	DICHTUNG DECKEL VENTILSTEUERUNG	JUNTA TAPA DISTRIBUCIÓN		1	
11	129106280030	ALBERO DISTRIBUZIONE ASPIRAZIONE	INTAKE CAMSHAFT	ARBRE DISTRIBUTION ASPIRATION	VERTEILERWELLE DER ANSAUGUNG	ARBOL DISTRIBUCIÓN ASPIRACIÓN	SPROCKET INCLUDED	1	
12	R320052252000	PIOLO (3X6)	PIN (3X6)	PIVOT (3X6)	STIFT (3X6)	ESPINA (3X6)		1	
13	129036220001	INGRANAGGIO ALBERO DISTRIBUZIONE ASPIRAZIONE	GEAR, INTAKE CAMSHAFT	ENGRENAGE ARBRE DISTRIBUTION ASPIRATION	ZAHNRAD, VERTEILERWELLE ANSAUGUNG	ENGRANAJE, ARBOL DISTRIBUCIÓN ASPIRACIÓN		1	
14	R320052194000	VITE (M7)	SCREW (M7)	VIS (M7)	SHARAUBE (M7)	TORNILLO (M7)		1	
15	R320434016000	INGRANAGGIO ALBERO DISTRIBUZIONE SCARICO	GEAR, EXHAUST CAMSHAFT	ENGRENAGE ARBRE DISTRIBUTION ÉCHAPPEMENT	ZAHNRAD, VERTEILERWELLE AUSLAß	ENGRANAJE, ARBOL DISTRIBUCIÓN DESCARGA		1	
16	129096280030	ALBERO DISTRIBUZIONE SCARICO	EXHAUST CAMSHAFT	ARBRE DISTRIBUTION ÉCHAPPEMENT	VERTEILERWELLE AUSLAß	ARBOL DISTRIBUCIÓN DESCARGA	SPROCKET INCLUDED	1	
17	R320052179000	VITE (M6X25)	SCREW (M6X25)	VIS (M6X25)	SHARAUBE (M6X25)	TORNILLO (M6X25)		1	
18	140036030000	TENDICATENA	CHAIN TENSIONER	TENDEUR DE CHAÎNE	KETTENSANNER	ENSOR DE CADENA		1	
19	140026280010	PATTINO CATENA INFERIORE	LOWER CHAIN SLIDING SHOE	PATIN CHAÎNE INFÉRIEURE	UNTERER KETTENGLEITSCHUH	PATÍN CADENA INFERIOR		1	
20	129026280000	CATENA DISTRIBUZIONE	CHAIN DISTRIBUTION	DISTRIBUTION À CHAÎNE	KETTENVERTEILUNG	DISTRIBUCIÓN DE CADENA		1	
21	149026280000	PATTINO CATENA	CHAIN SLIDING SHOE	PATIN CHAÎNE	KETTENGLEITSCHUH	PATÍN CADENA		1	
22	140186030000	PATTINO CATENA SUPERIORE	UPPER CHAIN SLIDING SHOE	PATIN CHAÎNE SUPÉRIEURE	OBERER KETTENGLEITSCHUH	PATÍN CADENA SUPERIOR		1	
23	R320079063000	GUARNIZIONE	GASKET	GARNITURE	DICHTUNG	JUNTA		1	
24	299073160000	CANDELA	SPARK PLUG	BOUIGE	ZÜNDKERZE	BUJIA		1	



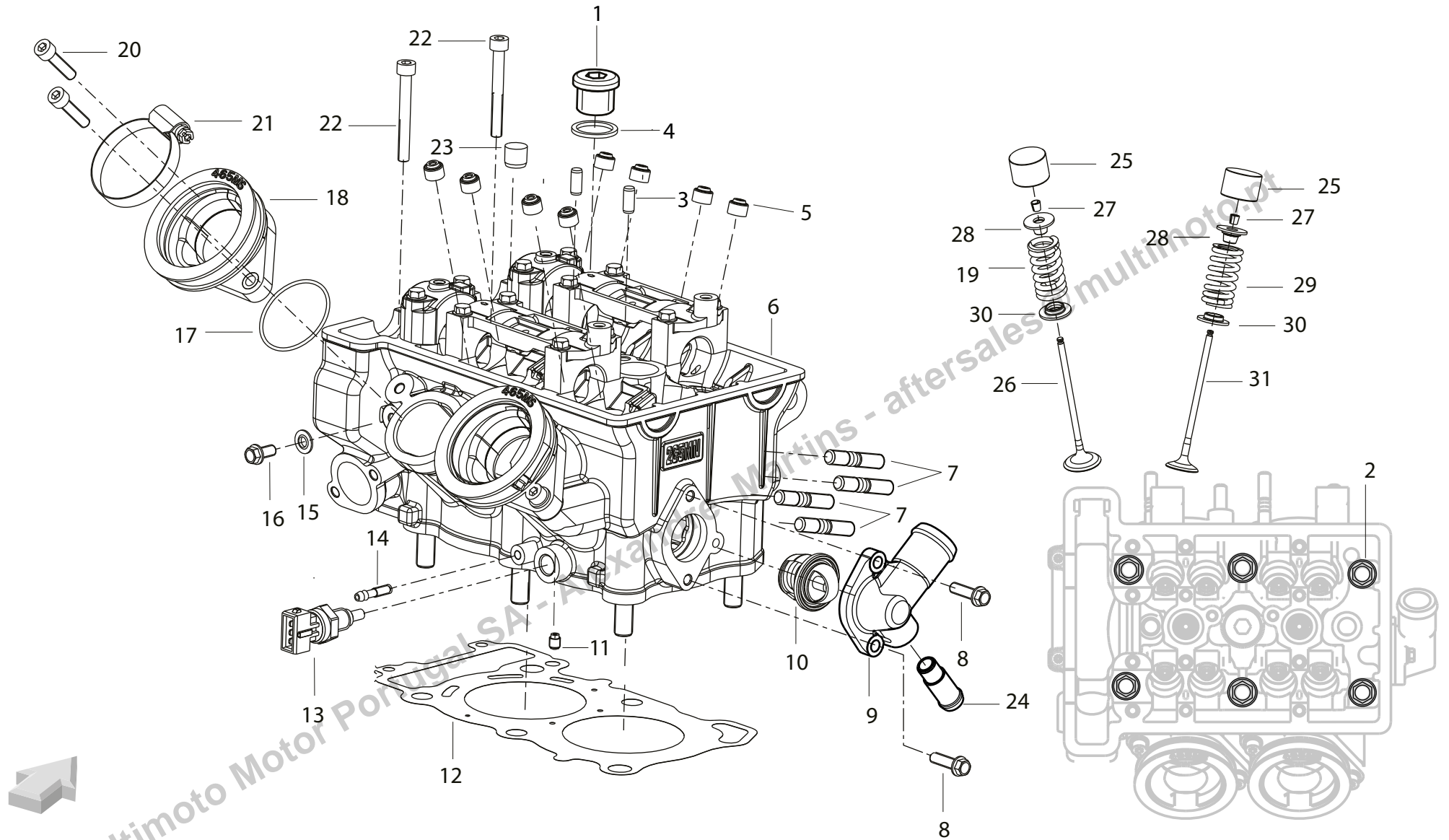

POS. NO. N. INDEX POS.	N. CODICE CODE NO. Nr. CODE ATRIKEL Nr. CODICO Nr.	DESCRIZIONE	DESCRIPTION	DESIGNATION	BEZEICHNUNG	DENOMINACION	NOTE NOTES NOTES MARKE NOTAS	Q.TA' CONF. Q.TY PACK. Q.TE EMB. M.GE PAK. C.AD PAQ.	
1	R320052228000	BOCCOLA (M20)	BUSH (M20)	DOUILLE (M20)	BUCHSE (M20)	CASQUILLO (M20)		1	
2	100236030000	VITE	SCREW	VIS	SCHRAUBE	TORNILLO		1	
3	R320452233000	BUSSOLA (6X14)	BUSH (6X14)	DOUILLE (6X14)	BUCHSE (6X14)	CASQUILLO (6X14)		1	
4	100126030000	RONDELLA	WASHER	RONDELLE	UNTERLEGSSCHEIBE	ARANDELA		1	
5	120126030000	GOMMINO VALVOLA	RUBBER PAD VALVE	JOINT EN CAOUTCHOUC SOUPAPE	GUMMISTÜCK AUSLAß	JUNTA DE GOMA VÁLVULA		1	
6	10905634NB01	TESTA CILINDRO (NERO)	CYLINDER HEAD (BLACK)	CULASSE CYLINDRE (NOIR)	ZYLINDERKOPFBEFESTIGUNG (SCHWARZES)	CULATA CILINDRO (NEGRO)		1	
7	10004609001X	PRIGIONIERO (M8)	STUD BOLT (M8X41)	GOIJON (M8X41)	STIFTSCHRAUBE (M8X41)	TORNILLO (M8X41)		2	
8	R320052177000	VITE (M6X20)	SCREW (M6X20)	VIS (M6X20)	SHARAUBE (M6X20)	TORNILLO (M6X20)		1	
9	27077628NB01	TAZZA TERMOSTATO	THERMOSTAT BELLEVILLE	BOL THERMOSTAT	THERMOSTATTELLER	TAZA TERMÓSTATO		1	
10	279165050000	TERMOSTATO	THERMOSTAT	THERMOSTAT	THERMOSTAT	TERMÓSTATO		1	
11	R320452247000	GRANO	DOWEL	VIS SANS TÊTE	STIFT	CLAVIJA		1	
12	109076280000	GUARNIZIONE TESTA	HEAD GASKET	GARNITURE TÊTE	DICHTUNG KOPF	JUNTA CULATA		1	
13	R320428064000	SENSORE TEMPERATURA ACQUA	WATER TEMPERATURE SENSOR	SONDE DE TEMPÉRATURE DE L'EAU	WASSEITEMPERATUR-SENSOR	SENSOR DE LA TEMPERATURA DEL AGUA		1	
14	100106030000	INSERTO	INSERT	INSERT	EINSATZ	INSERTO		1	
15	120133090002	RONDELLA DI TENUTA	STOP WASHER	RONDELLE D' ETANCHÉITÉ	DICHTUNGS RING	ARANDELA DE RETÉN		1	
16	R320052170000	VITE (M6X12)	SCREW (M6X12)	VIS (M6X12)	SHARAUBE (M6X12)	TORNILLO (M6X12)		1	
17	160056090000	GUARNIZIONE O-RING	O-RING	JOINT D' ETANCHÉITÉ	DICHTUNG O-RING	JUNTA OR		10	
18	280146030000	COLLETTORE ASPIRAZIONE	INTAKE MANIFOLD	COLLECTEUR ASPIRATION	ANSAUGKRÜMMER	COLECTOR ASPIRACIÓN		1	
19	120176220000	MOLLA VALVOLA	VALVE SPRING	RESSORT SOUPAPE	VENTIL FEDER	MUELLE VÁLVULA	STOP SUPPLY USE ONLY WITH B0205060256H	1	
20	B0205060206H	VITE (M6X20)	SCREW (M6X20)	VIS (M6X20)	SHARAUBE (M6X20)	TORNILLO (M6X20)	STOP SUPPLY USE ONLY WITH R320052276000	1	
21	R320052200000	FASCETTA A VITE	SCREW HOSE CLAMP	COLLIER À VISSER	SCHRAUBENSCHELLE	ABRAZADERA A TORNILLO		1	
22	R320452040000	VITE (M6X50)	SCREW (M6X50)	VIS (M6X50)	SHARAUBE (M6X50)	TORNILLO (M6X50)		1	
23	150166090000	TAPPO	CAP	BOUCHON	VERSCHLUB	TAPÓN		1	
24	120026280000	SPINA	PIN	GOUPILLE	STIFT	PASADOR		1	

POS. NO. N. INDEX POS.	N. CODICE CODE NO. Nr. CODE ATRÍKEL Nr. CODICO No.	DESCRIZIONE	DESCRIPTION	DESIGNATION	BEZEICHNUNG	DENOMINACION	NOTE NOTES NOTES MARKE NOTAS	Q.TA' CONF. Q.TY PACK. Q.TE EMB. M.GE PAK. C.AD PAQ.	
25	120506030430	BICCHIERINO VALVOLA (MM 430)	VALVE LIFTER BUCKET (MM 430)	POUSSOIR SOUPAPE (MM 430)	BECHERVENTIL (MM 430)	COPITA VÁLVULA (MM 430)		1	
25	120506030432	BICCHIERINO VALVOLA (MM 432)	VALVE LIFTER BUCKET (MM 432)	POUSSOIR SOUPAPE (MM 432)	BECHERVENTIL (MM 432)	COPITA VÁLVULA (MM 432)		1	
25	120506030434	BICCHIERINO VALVOLA (MM 434)	VALVE LIFTER BUCKET (MM 434)	POUSSOIR SOUPAPE (MM 434)	BECHERVENTIL (MM 434)	COPITA VÁLVULA (MM 434)		1	
25	120506030436	BICCHIERINO VALVOLA (MM 436)	VALVE LIFTER BUCKET (MM 436)	POUSSOIR SOUPAPE (MM 436)	BECHERVENTIL (MM 436)	COPITA VÁLVULA (MM 436)		1	
25	120506030438	BICCHIERINO VALVOLA (MM 438)	VALVE LIFTER BUCKET (MM 438)	POUSSOIR SOUPAPE (MM 438)	BECHERVENTIL (MM 438)	COPITA VÁLVULA (MM 438)		1	
25	120506030440	BICCHIERINO VALVOLA (MM 440)	VALVE LIFTER BUCKET (MM 440)	POUSSOIR SOUPAPE (MM 440)	BECHERVENTIL (MM 440)	COPITA VÁLVULA (MM 440)		1	
25	120506030442	BICCHIERINO VALVOLA (MM 442)	VALVE LIFTER BUCKET (MM 442)	POUSSOIR SOUPAPE (MM 442)	BECHERVENTIL (MM 442)	COPITA VÁLVULA (MM 442)		1	
25	120506030444	BICCHIERINO VALVOLA (MM 444)	VALVE LIFTER BUCKET (MM 444)	POUSSOIR SOUPAPE (MM 444)	BECHERVENTIL (MM 444)	COPITA VÁLVULA (MM 444)		1	
25	120506030446	BICCHIERINO VALVOLA (MM 446)	VALVE LIFTER BUCKET (MM 446)	POUSSOIR SOUPAPE (MM 446)	BECHERVENTIL (MM 446)	COPITA VÁLVULA (MM 446)		1	
25	120506030448	BICCHIERINO VALVOLA (MM 448)	VALVE LIFTER BUCKET (MM 448)	POUSSOIR SOUPAPE (MM 448)	BECHERVENTIL (MM 448)	COPITA VÁLVULA (MM 448)		1	
25	120506030450	BICCHIERINO VALVOLA (MM 450)	VALVE LIFTER BUCKET (MM 450)	POUSSOIR SOUPAPE (MM 450)	BECHERVENTIL (MM 450)	COPITA VÁLVULA (MM 450)		1	
25	120506030452	BICCHIERINO VALVOLA (MM 452)	VALVE LIFTER BUCKET (MM 452)	POUSSOIR SOUPAPE (MM 452)	BECHERVENTIL (MM 452)	COPITA VÁLVULA (MM 452)		1	
25	120506030454	BICCHIERINO VALVOLA (MM 454)	VALVE LIFTER BUCKET (MM 454)	POUSSOIR SOUPAPE (MM 454)	BECHERVENTIL (MM 454)	COPITA VÁLVULA (MM 454)		1	
25	120506030456	BICCHIERINO VALVOLA (MM 456)	VALVE LIFTER BUCKET (MM 456)	POUSSOIR SOUPAPE (MM 456)	BECHERVENTIL (MM 456)	COPITA VÁLVULA (MM 456)		1	
25	120506030458	BICCHIERINO VALVOLA (MM 458)	VALVE LIFTER BUCKET (MM 458)	POUSSOIR SOUPAPE (MM 458)	BECHERVENTIL (MM 458)	COPITA VÁLVULA (MM 458)		1	
25	120506030460	BICCHIERINO VALVOLA (MM 460)	VALVE LIFTER BUCKET (MM 460)	POUSSOIR SOUPAPE (MM 460)	BECHERVENTIL (MM 460)	COPITA VÁLVULA (MM 460)		1	
26	129186030000	VALVOLA ASPIRAZIONE	INTAKE VALVE	SOUPAPE D'ASPIRATION	EINLABVENTIL	VÁLVULA DE ASPIRACIÓN		1	
27	120086030000	SEMICONO VALVOLA	HALFCONE VALVE	DEMI-CONE SOUPAPE	HALFTENKEGEL VENTIL	SEMI-CONO VÁLVULA		1	
28	R320436123000	SCODELLINO SUPERIORE	UPPER RETAINER	CUVETTE SUPÉRIEURE	OBERER TELLER	PLATILLO SUPERIOR		1	
29	120186220000	MOLLA VALVOLA ESTERNA	VALVE EXTERNAL SPRING	RESSORT SOUPAPE EXTERNE	FEDER VENTIL EXTERN	MUELLE EXTERNAS		1	
30	R320417013000	SCODELLINO INFERIORE	LOWER RETAINER	CUVETTE INFÉRIEURE	TELLER UNTERER	PLATILLO INFERIOR		1	
31	129196030000	VALVOLA DI SCARICO	EXHAUST VALVE	SOUPAPE D'ÉCHAPPEMENT	AUSLABVENTIL	VÁLVULA DE DESGARGA		1	

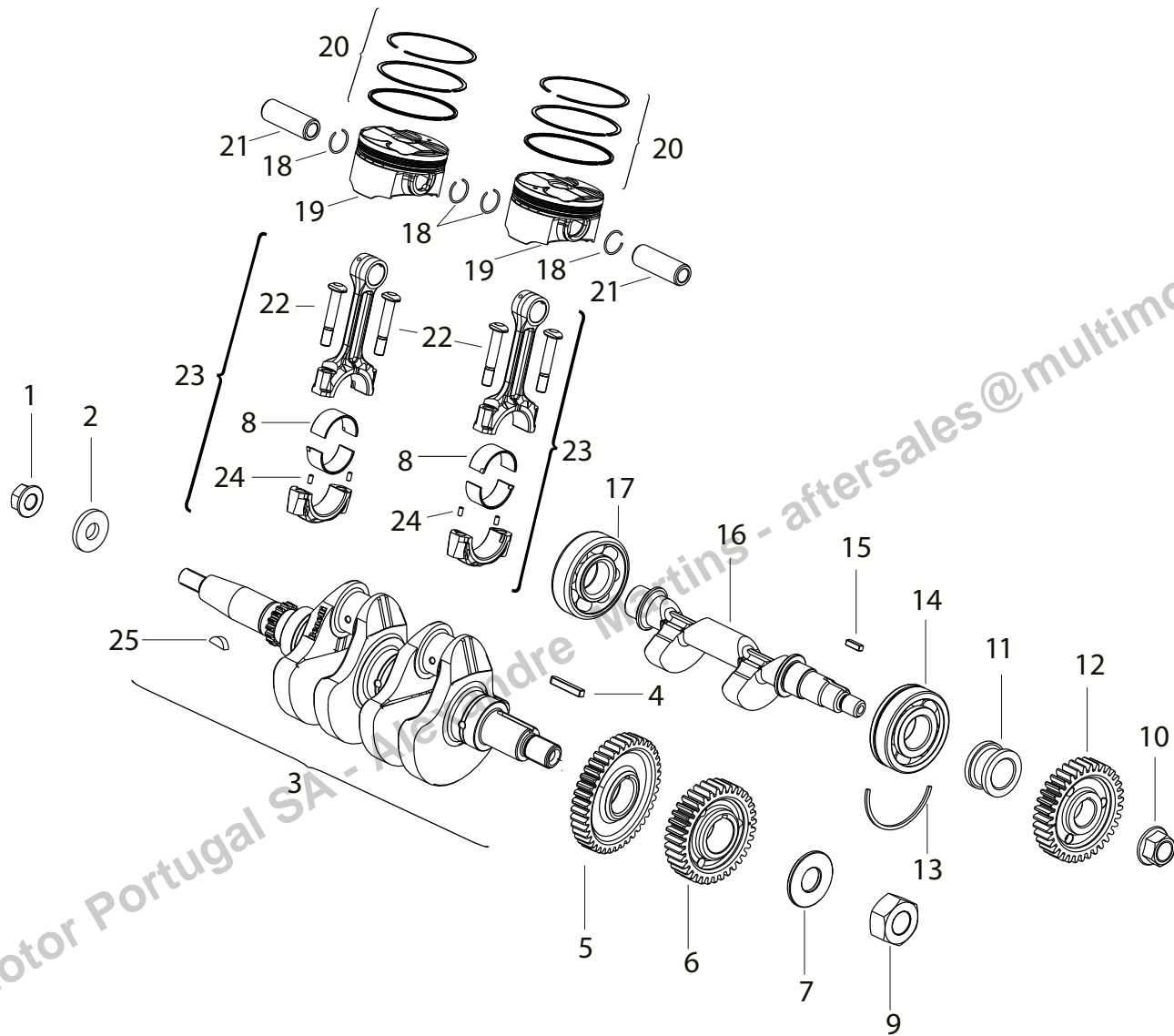

POS. NO. N. INDEX POS.	N. CODICE CODE NO. Nr. CODE ATRIKEL Nr. CODICO Nr.	DESCRIZIONE	DESCRIPTION	DESIGNATION	BEZEICHNUNG	DENOMINACION	NOTE NOTES NOTES MARKE NOTAS	Q.TA' CONF. Q.TY PACK. Q.TE EMB. M.GE PAK. C.AD PAQ.	
1	170044320000	DADO FLANGIATO (M14)	FLANGE NUT (M14)	ECROU BRIDE (M14)	FLANSCHMUTTER (M14)	TUERCA CON BRIDAS (M14)		1	
2	170106030010	RONDELLA	WASHER	RONDELLE	UNTERLEGSSCHEIBE	ARANDELA		1	
3	179016280010	ALBERO MOTORE	CRANKSHAFT	ARBRE MOTEUR	ANTRIEBWELLE	CIGÑEÑAL		1	
4	R320417047000	SPINA	PIN	GOUPILLE	STIFT	PASADOR		1	
5	170016280010	INGRANAGGIO	GEAR	ENGRENAGE	ZAHNRAD	ENGRANAJE		1	
6	179236220000	INGRANAGGIO ALBERO MOTORE	CRANKSHAFT GEAR	ENGRENAGE ARBRE MOTEUR	ZAHNRAD ANTRIEBWELLE	ENGRANAJE CIGÑEÑAL		1	
7	R320452065000	RONDELLA	WASHER	RONDELLE	UNTERLEGSSCHEIBE	ARANDELA		1	
8	179076280000	SEMICUSCINETTO DI BIELLA	HALF-BEARING	DEMI-ROULEMENT	HALBLAGER	SEMI-COJINETE	GREEN	1	
8	179076280010	SEMICUSCINETTO DI BIELLA	HALF-BEARING	DEMI-ROULEMENT	HALBLAGER	SEMI-COJINETE	YELLOW	1	
8	179076280020	SEMICUSCINETTO DI BIELLA	HALF-BEARING	DEMI-ROULEMENT	HALBLAGER	SEMI-COJINETE	BLUE	1	
9	R320452041000	DADO	NUT	ECROU	MUTTER	TUERCA		1	
10	R320452042000	DADO	NUT	ECROU	MUTTER	TUERCA		1	
11	170026280000	INGRANAGGIO CONTROALBERO	BALANCE SHAFT GEAR	ENGRANAGE D'AXE D'ÉQUILIBRE	BALANCE WELLE ZAHNRAD	ENGRANAJE DEL ARBOL DEL BALANCE		1	
12	179366220000	INGRANAGGIO CONTROALBERO	BALANCE SHAFT GEAR	ENGRANAGE D'AXE D'ÉQUILIBRE	BALANCE WELLE ZAHNRAD	ENGRANAJE DEL ARBOL DEL BALANCE		1	
13	R320004086000	FERMO CUSCINETTO	BEARING LOCK	ARRÊT ROULEMENT	STILLSTAND LAGER	SEGURO COJINETE		1	
14	210136030010	CUSCINETTO	BEARING	ROULEMENT	LAGER	COJINETE		1	
15	B11130044014	SPINA	PIN	GOUPILLE	STIFT	PASADOR		5	
16	179256280010	CONTROALBERO	BALANCE SHAFT	D'AXE D'ÉQUILIBRE	BALANCE WELLE	ARBOL DEL BALANCE		1	
17	R320452209000	CUSCINETTO	BEARING	ROULEMENT	LAGER	COJINETE		1	
18	179155050000	ANELLINO FERMA SPINOTTO	CIRCLIP PISTON PIN	BAGUE ELASTIQUE BLOQUE-AXE	SPRENGRING BOLZENFESTSTELLUNG	ANILLO ELASTICO EJE PISTON		2	
19	179136280010	PISTONE	PISTON	PISTON	KOLBEN	PISTÓN		1	
20	170046280000	SERIE SEGMENTI PISTONE	PISTON RINGS SET	ETUI SEGMENTS	BEUTEL MIT KOLBENRINGEN	SERIE DE SEGMENTOS		1	
21	179146280010	SPINOTTO PER PISTONE	PISTON PIN	AXE DE PISTON	KOLBENBOLZEN	BULÓN		1	
22	170036280000	VITE (M8)	SCREW (M8)	VIS (M8)	SHARAUBE (M8)	TORNILLO (M8)		1	

 **ASSIEME MANOVELLISMO**

 **CRANK GEAR ASSEMBLY**

 **ENSEMBLE BIELLISME**

 **KURBELGETRIEBE KOMPLETT**

 **JUNTO CINEMATISMO**

POS. NO. N. INDEX POS.	N. CODICE CODE NO. Nr. CODE ATRIKEL Nr. CODICO Nr.	DESCRIZIONE	DESCRIPTION	DESIGNATION	BEZEICHNUNG	DENOMINACION	NOTE NOTES NOTES MARKE NOTAS	Q.TA' CONF. Q.TY PACK. Q.TE EMB. M.GE PAK. C.AD PAQ.	
23	179036280000	BIELLA	CONNECTING ROD	BIELLE	KOLBENSTANGE	BIELA		1	
24	B091403006A1	BOCCOLA DI GUIDA	BUSH OF GUIDE	DOUILLE DE GUIDE	BUCHSE DES GUIDE	CASQUILLO DE GUÍA		1	
25	170065050000	LINGUETTA AMERICANA	WOODRUFF KEY	LANGUETTE AMÉRICAINNE	HALBRUNDKEIL	CHAVETA AMERICANA		1	



Multimoto Motor Portugal SA - Alexandre Martins - aftersales@multimoto.pt

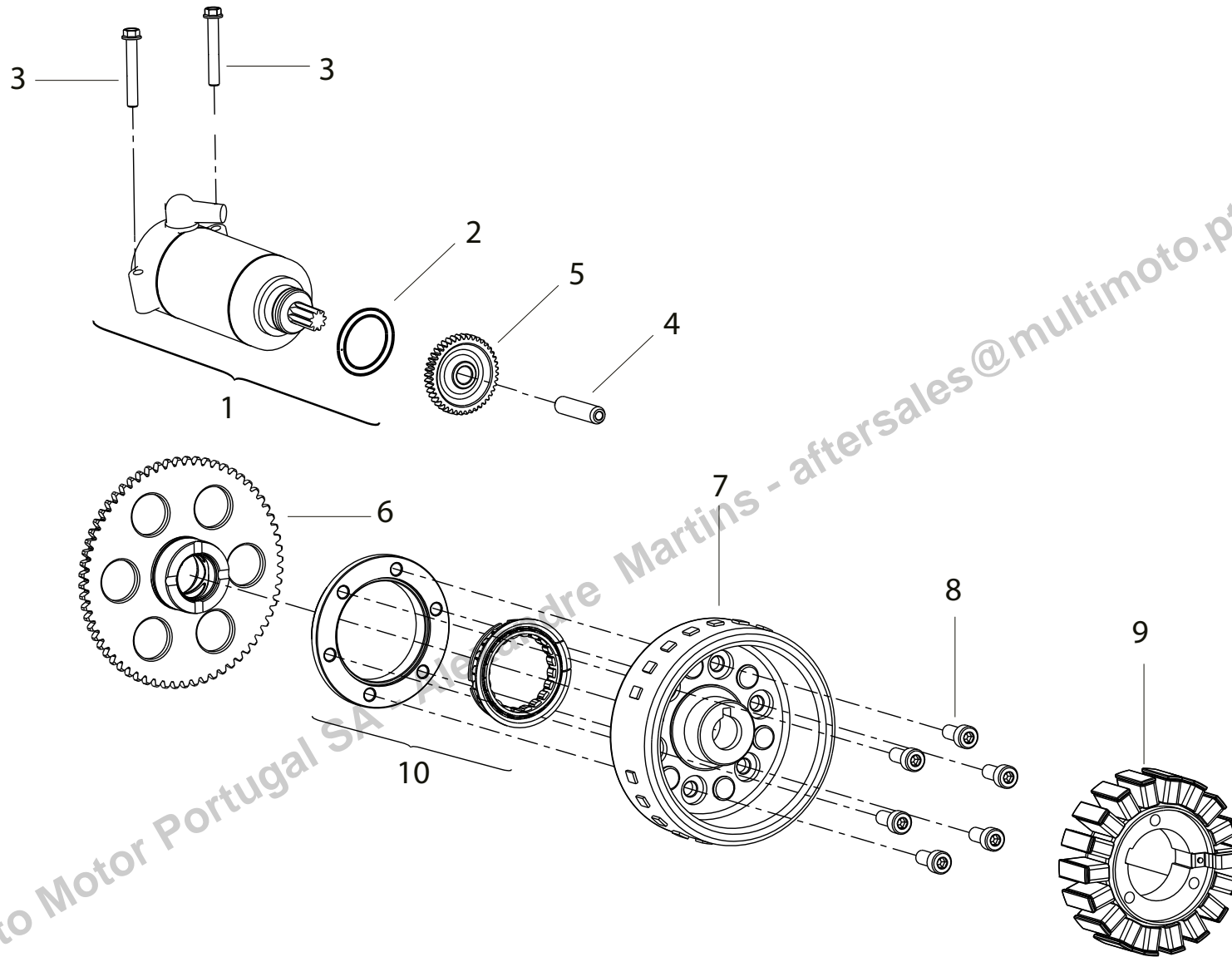

POS. NO. N. INDEX POS.	N. CODICE CODE NO. Nr. CODE ATRÍKEL Nr. CODICO Nr.	DESCRIZIONE	DESCRIPTION	DESIGNATION	BEZEICHNUNG	DENOMINACION	NOTE NOTES NOTES MARKE NOTAS	Q.TA' CONF. Q.TY PACK. Q.TE EMB. M.GE PAK. C.AD PAQ.	
1	249066280010	MOTORINO AVVIAMENTO	STARTER MOTOR	DÉMARREUR	ELEKTRISCHER ANLABMOTOR	MOTOR DE ARRANQUE		1	
2	R120003055000	GUARNIZIONE O-RING	O-RING	JOINT D'ÉTANCHÉITÉ	DICHTUNG O-RING	JUNTA OR		1	
3	R320052182000	VITE (M6X40)	SCREW (M6X40)	VIS (M6X40)	SHARAUBE (M6X40)	TORNILLO (M6X40)		1	
4	R320034033000	ALBERINO AVVIAMENTO	SPINDLE KICK STARTER	BROCHE DE KICK DE DEMARRAGE	KICKSTARTERSPINDEL	EJE, ARRANQUE		1	
5	249046280000	INGRANAGGIO DOPPIO	DOUBLE GEAR	ENGRANAGE DOUBLE	DOPPELTES FREILAUFRAD	ENGRANAJE DOBLE		1	
6	249016280000	INGRANAGGIO AVVIAMENTO	GEAR, STARTER IDLER	PIGNON DE KICK	KICKSTARTERRITZEL	ENGRANAJE PINON ARRANQUE		1	
7	299026280020	ROTORE VOLANO MAGNETE	ROTOR MAGNETO FLYWHEEL	ROTOR VOLANT MAGNETIQUE	SCHWUNGRAD ROTOR	ROTOR VOLANTE MAGNETICO		1	
8	B0207080168H	VITE (M8X16)	SCREW (M8X16)	VIS (M8X16)	SHARAUBE (M8X16)	TORNILLO (M8X16)		1	
9	299036280030	STATORE VOLANO MAGNETE	STATOR MAGNETO FLYWHEEL	STATOR VOLANT MAGNETO	SCHWUNGRAD KOMPLETT	STATOR VOLANTE MAGNÉTICO		1	
10	249106280000	RUOTA LIBERA COMPLETA	COMPLETE STARTER CLUTCH	ROUE LIBRE COMPLET	FREILAUF KOMPLETT	RUEDA LIBRE COMPLETA		1	



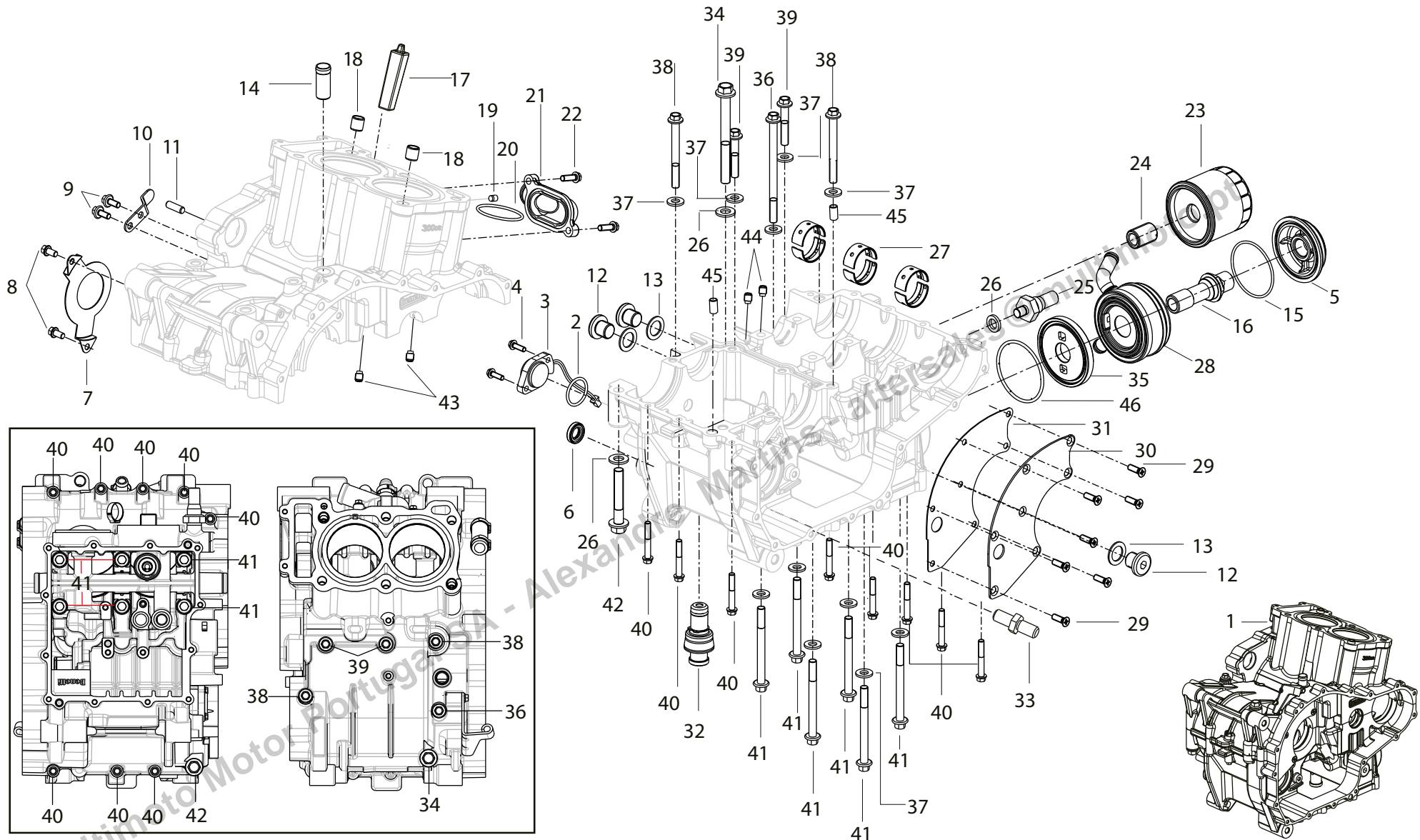

POS. NO. N. INDEX POS.	N. CODICE CODE NO. Nr. CODE ATRIBEL Nr. CODICO Nr.	DESCRIZIONE	DESCRIPTION	DESIGNATION	BEZEICHNUNG	DENOMINACION	NOTE NOTES NOTES MARKE NOTAS	Q.TA' CONF. Q.TY PACK. Q.TE EMB. M.GE PAK. C.AD PAQ.	
1	15005628NB01	CARTER MOTORE (NERO)	CRANKCASE SET (BLACK)	CARTER MOTEUR (NOIR)	KURBELWELLENGEHAUSE (SCHWARZES)	CARTER MOTOR (NEGRO)		1	
2	B190102580B0	GUARNIZIONE O-RING	O-RING	JOINT D'ÉTANCHÉITÉ	DICHTUNG O-RING	JUNTA OR		1	
3	150196030020	SENSORE FOLLE	NEUTRAL SENSOR	CAPTEUR DU NEUTRE	SENSOR LEERLAUFSCHALTER	SENSOR LIBRE		1	
4	R320052167000	VITE (M5X16)	SCREW (M5X16)	VIS (M5X16)	SHARAUBE (M5X16)	TORNILLO (M5X16)		1	
5	150156280030	TAPPO	CAP	BOUCHON	VERSCHLUß	TAPÓN		1	
6	150025040000	PARAOILIO	OIL SEAL	BAGUE D'ETANCHEITE	WELLENDICHRING	RETEN DE ACEITE		1	
7	150346030030	PIASTRINO	PLATE	PLAQUETTE	PLÄTTCHEN	LÁMINA		1	
8	B0107060126H	VITE (M6X12)	SCREW (M6X12)	VIS (M6X12)	SHARAUBE (M6X12)	TORNILLO (M6X12)		1	
9	B01070601464	VITE (M6X14)	SCREW (M6X14)	VIS (M6X14)	SHARAUBE (M6X14)	TORNILLO (M6X14)		1	
10	R320401007000	PIASTRINO	PLATE	PLAQUETTE	PLÄTTCHEN	LÁMINA		1	
11	R320452282000	SPINA	PIN	GOUPILLE	STIFT	PASADOR		1	
12	R320052197000	VITE SPECIALE	SPECIAL SCREW	VIS SPÉCIALE	SPEZIALSCHRAUBE	TORNILLO ESPECIAL		1	
13	150086220000	RONDELLA DI TENUTA	STOP WASHER	RONDELLE D'ETANCHÉITÉ	DICHTUNGS RING	ARANDELA DE RETÉN		1	
14	R320490048000	INSERTO	INSERT	INSERT	EINSATZ	INSERTO		1	
15	120055050000	GUARNIZIONE O-RING	O-RING	JOINT D'ÉTANCHÉITÉ	DICHTUNG O-RING	JUNTA OR		1	
16	150146280000	VITE SPECIALE	SPECIAL SCREW	VIS SPÉCIALE	SPEZIALSCHRAUBE	TORNILLO ESPECIAL		1	
17	R320479059000	GOMMINO	RUBBER PAD	JOINT EN CAOUTCHOUC	GUMMISTÜCK	JUNTA DE GOMA		1	
18	R14013151A	BUSSOLA DI CENTRAGGIO	CENTRING BUSH	DOUILLE DE CENTRAGE	ZENTRIERBUCHSE	CASQUILLO DE CENTRADO		2	
19	150103070000	BOCCOLA	BUSH	DOUILLE	BUCHSE	CASQUILLO		2	
20	150066030000	GUARNIZIONE O-RING	O-RING	JOINT D'ÉTANCHÉITÉ	DICHTUNG O-RING	JUNTA OR		1	
21	15016628NB01	RACCORDO ACQUA	WATER UNION	RACCORD D'EAU	WASSERANSCHLUß	EMPALME AGUA		1	
22	R320052177000	VITE (M6X20)	SCREW (M6X20)	VIS (M6X20)	SHARAUBE (M6X20)	TORNILLO (M6X20)		1	
23	260146090010	FILTRO OLIO	OIL FILTER	FILTRE À HUILE	ÖLFILTER	FILTRO ACEITE		1	
24	160106110000	RACCORDO	UNION	RACCORD	ANSCHLUß	EMPALME		1	

POS. NO. N. INDEX POS.	N. CODICE CODE NO. Nr. CODE ATRIBEL Nr. CODICO Nr.	DESCRIZIONE	DESCRIPTION	DESIGNATION	BEZEICHNUNG	DENOMINACION	NOTE NOTES NOTES MARKE NOTAS	Q.TA' CONF. Q.TY PACK. Q.TE EMB. M.GE PAK. C.AD PAQ.	
25	240026090000	SENSORE PRESSIONE OLIO	OIL PRESSURE SENSOR	CAPTEUR PRESSION D' HUILE	ÖLDRUCKSENSOR	SENSOR PRESIÓN ACEITE		1	
26	R180132106000	GUARNIZIONE ALLUMINIO	ALLUMINIUM GASKET	GARNITURE ALUMINIUM	ALUMINIUM-DICHTUNG STÄRKE	JUNTA ALUMINIO		1	
27	150026280030	CUSCINETTO	BEARING	ROULEMENT	LAGER	COJINETE		1	
28	150136280000	SCAMBIATORE ACQUA OLIO	WATER OIL EXCHANGER	ÉCHANGEUR D' HUILE DE L'EAU	AUSTAUSCHER WASSER-ÖL	CAMBIADOR DEL ACEITE DEL AGUA		1	
29	R320452075000	VITE (M6X16)	SCREW (M6X16)	VIS (M6X16)	SHARAUBE (M6X16)	TORNILLO (M6X16)		1	
30	R320479064000	FLANGIA	FLANGE	BRIDE	FLANSCH	BRIDA		1	
31	R320479065000	GUARNIZIONE	GASKET	GARNITURE	DICHTUNG	JUNTA		1	
32	260126030010	VALVOLA SOVRAPRESSIONE OLIO	OIL OVER PRESURE VALVE	SOUPAPE SURPRESSION HUILE	ÜBERDRUCK ÖLVENTIL	VÁLVULA SUPERPRESIÓN ACEITE		1	
33	R320052196000	VITE SPECIALE	SPECIAL SCREW	VIS SPÉCIALE	SPEZIALSCHRAUBE	TORNILLO ESPECIAL		1	
34	R320052162000	VITE (M10X100)	SCREW (M10X100)	VIS (M10X100)	SCHRAUBE (M10X100)	TORNILLO (M10X100)		1	
35	150126280000	RACCORDO	UNION	RACCORD	ANSCHLUß	EMPALME		1	
36	R320052187000	VITE (M8X115)	SCREW (M8X115)	VIS (M8X115)	SHARAUBE (M8X115)	TORNILLO (M8X115)		1	
37	150156030000	RONDELLA	WASHER	RONDELLE	UNTERLEGSCHIEBE	ARANDELA		1	
38	R320052191000	VITE (M8X75)	SCREW (M8X75)	VIS (M8X75)	SHARAUBE (M8X75)	TORNILLO (M8X75)		1	
39	R320052188000	VITE (M8X45)	SCREW (M8X45)	VIS (M8X45)	SHARAUBE (M8X45)	TORNILLO (M8X45)		1	
40	R320052182000	VITE (M6X40)	SCREW (M6X40)	VIS (M6X40)	SHARAUBE (M6X40)	TORNILLO (M6X40)		1	
41	B01070808591	VITE (M8X85)	SCREW (M8X85)	VIS (M8X85)	SCHRAUBE (M8X85)	TORNILLO (M8X85)		1	
42	R320052163000	VITE (M10X60)	SCREW (M10X60)	VIS (M10X60)	SCHRAUBE (M10X60)	TORNILLO (M10X60)		1	
43	R320052247000	GRANO	DOWEL	VIS SANS TÊTE	STIFT	CLAVIJA		1	
44	150076280000	INSERTO	INSERT	INSERT	EISATZ	INSERTO		1	
45	R320004046000	BUSSOLA DI CENTRAGGIO	CENTRING BUSH	DOUILLE DE CENTRAGE	ZENTRIERBUCHSE	CASQUILLO DE CENTRADO		4	
46	270056030000	GUARNIZIONE O-RING	O-RING	JOINT D'ÉTANCHÉITÉ	DICHTUNG O-RING	JUNTA OR		1	

🇮🇹 COPERCHIO
MOTORE SINISTRO

🇬🇧 L.H. ENGINE
COVER

🇫🇷 COUVERCLE
MOTEUR GAUCHE

🇩🇪 LINKER DECKEL
MOTOR

🇪🇸 TAPA MOTOR
IZQUIERDO

TAVOLA
DRAWING
TABLE
BILD
TABLA

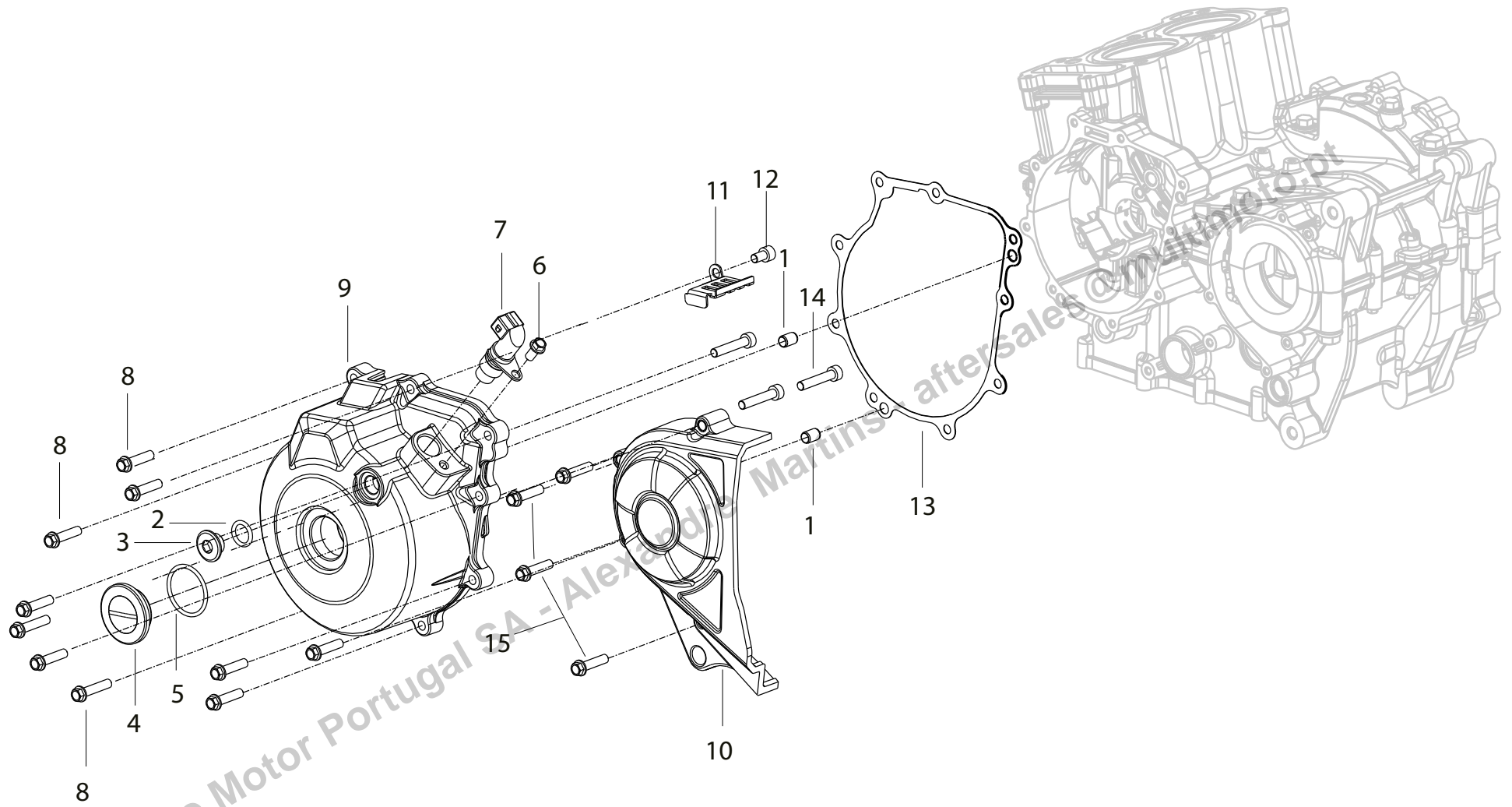

POS. NO. N. INDEX POS.	N. CODICE CODE NO. Nr. CODE ATRÍKEL Nr. CODICO Nr.	DESCRIZIONE	DESCRIPTION	DESIGNATION	BEZEICHNUNG	DENOMINACION	NOTE NOTES NOTES MARKE NOTAS	Q.TA' CONF. Q.TY PACK. Q.TE EMB. M.GE PAK. C.AD PAQ.	
1	R320052233000	BUSSOLA	BUSH	DOUILLE	BUCHSE	CASQUILLO		1	
2	B190101330B0	GUARNIZIONE O-RING	O-RING	JOINT D'ÉTANCHÉITÉ	DICHTUNG O-RING	JUNTA OR		1	
3	16005307NB01	TAPPO FILETTATO	THREADED CAP	BOUCHON FILETÉE	GEWINDE VERSCHLUß	TAPÓN FILETEADO	GREY	1	
4	16916603NB01	TAPPO MAGNETICO	MAGNETIC CAP	BOUCHON MAGNÉTIQUE	VERSCHLUß MAGNETISCH	TAPÓN MAGNÉTICO		1	
5	160076030000	GUARNIZIONE O-RING	O-RING	JOINT D'ÉTANCHÉITÉ	DICHTUNG O-RING	JUNTA OR		1	
6	R320052170000	VITE (M6X12)	SCREW (M6X12)	VIS (M6X12)	SHARAUBE (M6X12)	TORNILLO (M6X12)		1	
7	290016220000	SENSORE DI FASE	PHASE SENSOR	CAPTEUR DE PHASE	PHASENFÜHLER	SENSOR DE FASE		1	
8	160106030120	VITE (M6X25)	SCREW (M6X25)	VIS (M6X25)	SHARAUBE (M6X25)	TORNILLO (M6X25)		1	
9	16902622NB01	COPERCHIO ALTERNATORE (NERO)	GENERATOR COVER (BLACK)	COUVERCLE ALTERNATEUR (NOIR)	DECKEL DES DREHSTROMGENERATORS (SCHWARZ)	TAPA ALTERNADOR (NEGRO)		1	
10	16904628NB01	COPERCHIO PIGNONE (NERO)	SPROCKET COVER (BLACK)	COUVERTURE PIGNON (NOIR)	DECKELRITZEL (SCHWARZ)	TAPA PIÑÓN (NEGRO)		1	
11	160046030000	PIASTRINO	PLATE	PLAQUETTE	PLÄTTCHEN	LÁMINA		1	
12	B0205060128H	VITE (M6X12)	SCREW (M6X12)	VIS (M6X12)	SHARAUBE (M6X12)	TORNILLO (M6X12)		1	
13	169076220000	GUARNIZIONE COPERCHIO VOLANO	FLYWHEELCOVER GASKET	GARNITURE COUVERCLE VOLANT	DICHTUNG DECKEL SCHWUNGRAD	JUNTA TAPA VOLANTE		1	
14	R320034015000	VITE (M6X32)	SCREW (M6X32)	VIS (M6X32)	SHARAUBE (M6X32)	TORNILLO (M6X32)		1	
15	R020051134000	VITE (M6X30)	SCREW (M6X30)	VIS (M6X30)	SHARAUBE (M6X30)	TORNILLO (M6X30)		1	

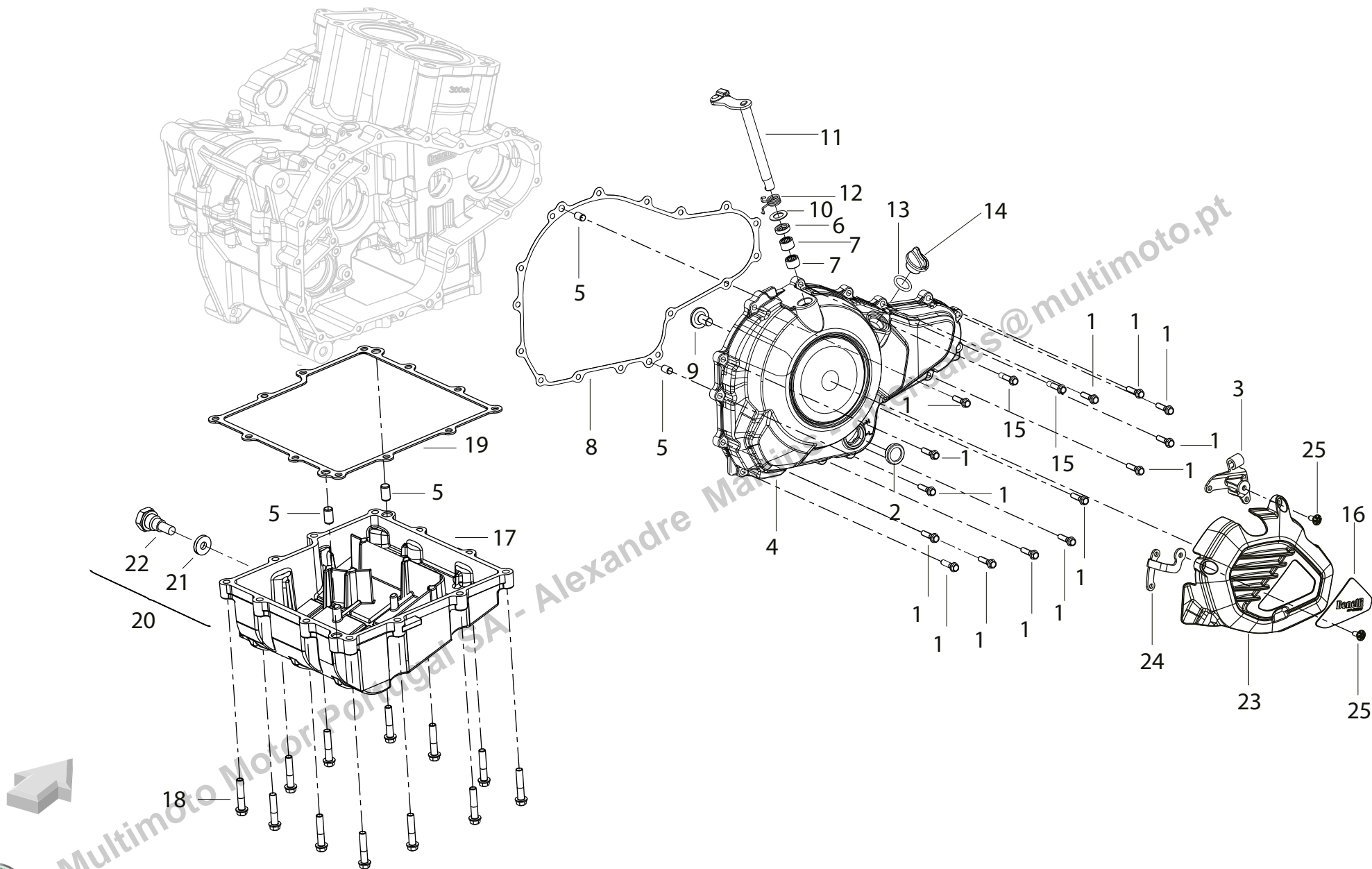

POS. NO. N. INDEX POS.	N. CODICE CODE NO. Nr. CODE ATRIBEL Nr. CODICO Nr.	DESCRIZIONE	DESCRIPTION	DESIGNATION	BEZEICHNUNG	DENOMINACION	NOTE NOTES NOTES MARKE NOTAS	Q.TA' CONF. Q.TY PACK. Q.TE EMB. M.GE PAK. C.AD PAQ.	
1	R320052179000	VITE (M6X25)	SCREW (M6X25)	VIS (M6X25)	SHARAUBE (M6X25)	TORNILLO (M6X25)		1	
2	160083090000	OBLÒ ISPEZIONE LIVELLO OLIO	OIL LEVEL SIGHT GLASS	HUBLOT D'INSPECTION NIVEAU HUILE	ÖLKONTROLLSCHAUGLAS	VISOR DE INSPECCIÓN NIVEL ACEITE		1	
3	160096340000	PIASTRINO	PLATE	PLAQUETTE	PLÄTTCHEN	LÁMINA		1	
4	16910628NB01	COPERCHIO FRIZIONE (NERO)	CLUTCH COVER (BLACK)	COUVERCLE EMBRAYAGE (NOIR)	KUPPLUNGSDECKEL (SCHWARZ)	CARTER EMBRAGUE (NEGRO)		1	
5	160073070000	BOCCOLA	BUSH	DOUILLE	BUCHSE	CASQUILLO		1	
6	200001050000	PARAOILIO	OIL SEAL	BAGUE D'ETANCHEITE	WELLENDICHTRING	RETEN DE ACEITE		1	
7	B1212K121002	CUSCINETTO A RULLI	BEARING, NEEDLE	ROULEMENT À ROULEAUX	ROLLENLAGER	COJINETE DE RODILLOS		1	
8	R320479066000	GUARNIZIONE COPERCHIO FRIZIONE	CLUTCH COVER GASKET	GARNITURE COUVERCLE EMBRAYAGE	DECKEL DICHTUNG KUPPLUNG	JUNTA TAPA EMBRAGUE		1	
9	200066280000	BOCCOLA DI GUIDA	BUSH OF GUIDE	DOUILLE DE GUIDE	BUCHSE DES GUIDE	CASQUILLO DE GUÍA		1	
10	R320052264000	RONDELLA	WASHER	RONDELLE	UNTERLEGSSCHEIBE	ARANDELA		1	
11	200096280010	ALBERO COMANDO FRIZIONE	CLUTCH CONTROL SHAFT	ARBRE COMMANDE EMBRAYAGE	KUPPLUNGSSTEUERUNG WELLE	ARBOL ACCINAMENTO EMBRAGUE		1	
12	200046030000	MOLLA	SPRING	RESSORT	FEDER	MUELLE		1	
13	R050307054000	GUARNIZIONE O-RING (18X3.5)	O-RING (18X3.5)	BAGUE D'ÉTANCHÉITÉ (18X3.5)	O-RING (18X3.5)	ANILLO OR (18X3.5)		1	
14	16006309NB01	TAPPO CARICO OLIO	OIL LOAD PLUG	BOUCHON REMPLISSAGE HUILE	ÖLEINFÜLLSCHRAUBE	TAPÓN CARGO ACEITE		1	
15	R320452043000	VITE (M6X28)	SCREW (M6X28)	VIS (M6X28)	SHARAUBE (M6X28)	TORNILLO (M6X28)		1	
16	160086280000	ADESIVO (BENELLI)	STICKER (BENELLI)	DÉCALCOMANIE (BENELLI)	AUFKLEBER (BENELLI)	ADHESIVO (BENELLI)		1	
17	26001622NB01	COPPA OLIO (NERO)	OIL SUMP (BLACK)	CARTER D'HUILE (NOIR)	ÖLWANNE (SCHWARZ)	CÁRTER DE ACEITE (NEGRO)		1	
18	160106030130	VITE (M6X30)	SCREW (M6X30)	VIS (M6X30)	SHARAUBE (M6X30)	TORNILLO (M6X30)		1	
19	260036220000	GUARNIZIONE COPPA OLIO	OIL SUMP GASKET	GARNITURE CARTER INFERIEUR (HUILE)	DICHTUNG ÖLWANNE	JUNTA COPA ACEITE		1	
20	260346030010	TAPPO MAGNETICO	MAGNETIC CAP	BOUCHON MAGNÉTIQUE	VERSCHLUB MAGNETISCH	TAPÓN MAGNÉTICO		1	
21	R180270007000	RONDELLA DI TENUTA	STOP WASHER	RONDELLE D'ÉTANCHÉITÉ	DICHTUNGS RING	ARANDELA DE RETÉN		1	
22	R180270006000	TAPPO MAGNETICO	MAGNETIC CAP	BOUCHON MAGNÉTIQUE	VERSCHLUB MAGNETISCH	TAPÓN MAGNÉTICO		1	
23	16009628BG01	PROTEZIONE MOTORE DX	R.H. ENGINE PROTECTION	PROTECTION MOTEUR DROITE	SCHUTZ MOTOR RECHTES	PROTECCIÓN MOTOR DER.		1	
24	160106340000	PIASTRINO	PLATE	PLAQUETTE	PLÄTTCHEN	LÁMINA		1	
25	B0284060150A	VITE (M6X15.2)	SCREW (M6X15.2)	VIS (M6X15.2)	SHARAUBE (M6X15.2)	TORNILLO (M6X15.2)		1	

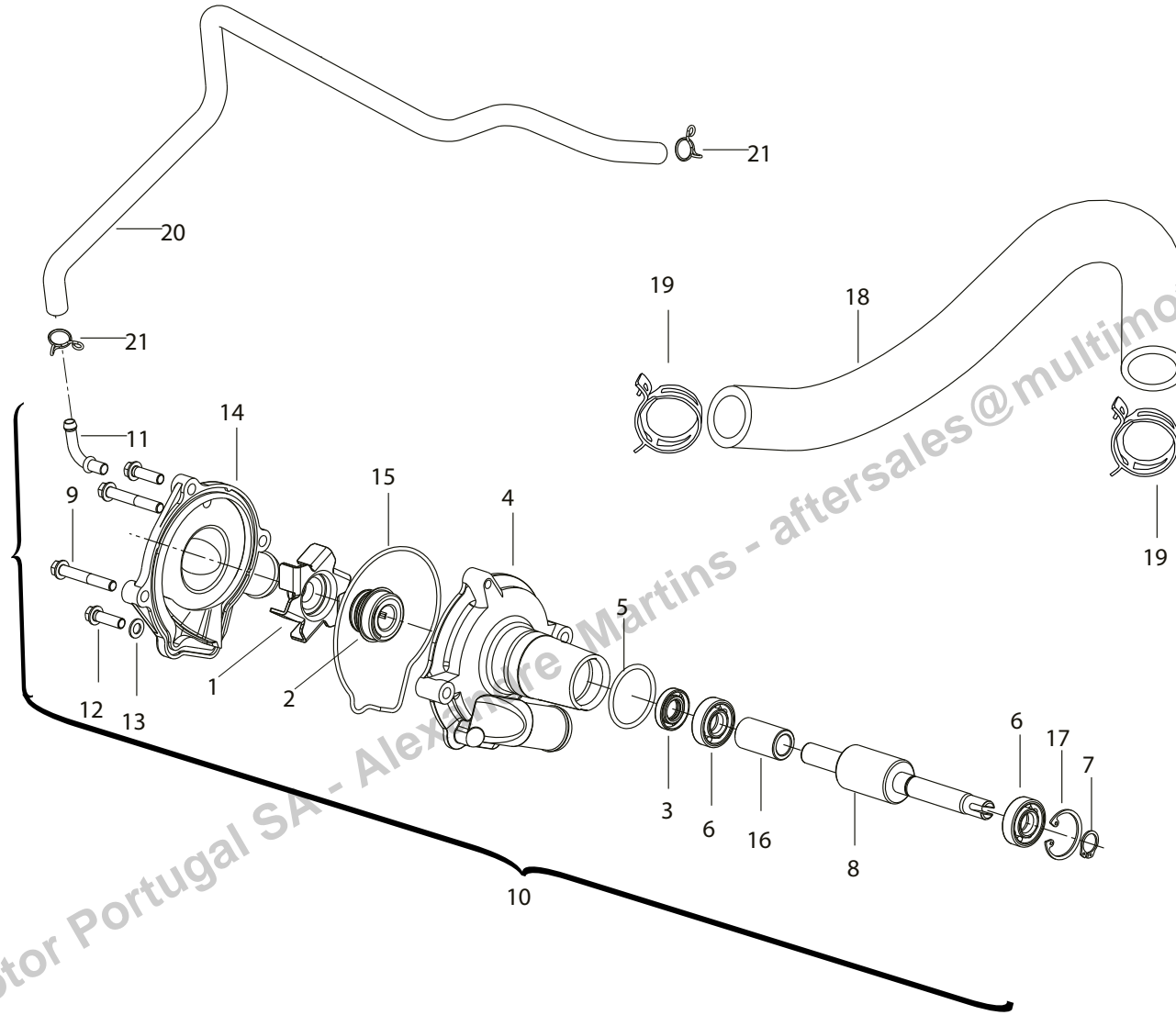

POS. NO. N. INDEX POS.	N. CODICE CODE NO. Nr. CODE ATRÍKEL Nr. CODICO Nr.	DESCRIZIONE	DESCRIPTION	DESIGNATION	BEZEICHNUNG	DENOMINACION	NOTE NOTES NOTES MARKE NOTAS	Q.TA' CONF. Q.TY PACK. Q.TE EMB. M.GE PAK. C.AD PAQ.	
1	279216030000	GIRANTE POMPA ACQUA	WATER PUMP FAN	COURONNE POMPE EAU	GIRANT DER WASSERPUMPE	ROTOR BOMBA AGUA		1	
2	270216030000	TENUTA MECCANICA	MECHANICAL SEAL	TENUE MÉCANIQUE	MECHANISCHE DICHTUNG	JUNTA MECÁNICA		1	
3	270153160000	PARAOILIO	OIL SEAL	BAGUE D'ÉTANCHEITE	WELLENDICHRING	RETEN DE ACEITE		1	
4	279316030030	COPERCHIO POMPA ACQUA (NERO)	WATER PUMP COVER (BLACK)	COUVERCLE POMPE À EAU (NOIR)	WASSERPUMPENDECKEL (SCHWARZ)	TAPA BOMBA AGUA (NEGRO)		1	
5	B190100335B0	GUARNIZIONE O-RING	O-RING	JOINT D'ÉTANCHÉITÉ	DICHTUNG O-RING	JUNTA OR		1	
6	B12016000100	CUSCINETTO	BEARING	ROULEMENT	LAGER	COJINETE		1	
7	R700052060000	ANELLO SEEGER	CIRCLIP	CIRCLIP	SEEGERRING	ANILLO SEEGER		1	
8	27922603001X	ALBERO POMPA ACQUA	WATER PUMP SHAFT	ARBRE POMPE EAU	WASSERPUMPEWELLE	ARBOL BOMBA AGUA		1	
9	R320052182000	VITE (M6X40)	SCREW (M6X40)	VIS (M6X40)	SHARAUBE (M6X40)	TORNILLO (M6X40)		1	
10	27920603NB01	POMPA ACQUA COMPLETA (NERO)	COMPLETE WATER PUMP (BLACK)	POMPE EAU COMPLET (NOIR)	KOMPLETT WASSERPUMPE (SCHWARZ)	BOMBA AGUA COMPLETA (NEGRO)		1	
11	R320036126000	RACCORDO "L"	UNION "L"	RACCORD "L"	ANSCHLUB "L"	EMPALME "L"		1	
12	270156030000	VITE (M6X20)	SCREW (M6X20)	VIS (M6X20)	SHARAUBE (M6X20)	TORNILLO (M6X20)		1	
13	270345050000	RONDELLA	WASHER	RONDELLE	UNTERLEGSCHIEBE	ARANDELA		1	
14	279336030030	CORPO POMPA ACQUA (NERO)	WATER PUMP BODY (BLACK)	CORPS POMPE EAU (NOIR)	KÖRPER WASSERPUMPE (SCHWARZ)	CUERPO BOMBA AGUA (NEGRO)		1	
15	270066030000	ANELLO DI TENUTA	SEAL RING	BAGUE D'ÉTANCHÉITÉ	DICHRING	ANILLO DE RETÉN		1	
16	R320052300000	BOCCOLA	BUSH	DOUILLE	BUCHSE	CASQUILLO		1	
17	B08000002801	ANELLO SEEGER	CIRCLIP	CIRCLIP	SEEGERRING	ANILLO SEEGER		1	
18	279106280000	MANICOTTO	HOSE	MANCHON	MUFFE	MANGUETA		1	
19	06103P160000	FASCETTA	CLAMP	COLLIER	SHELLE	ABRAZADERA		1	
20	279116280000	TUBO	TUBE	TUBE	ROHR	TUBO		1	
21	R030652288000	MOLLA	SPRING	RESSORT	FEDER	MUELLE		10	

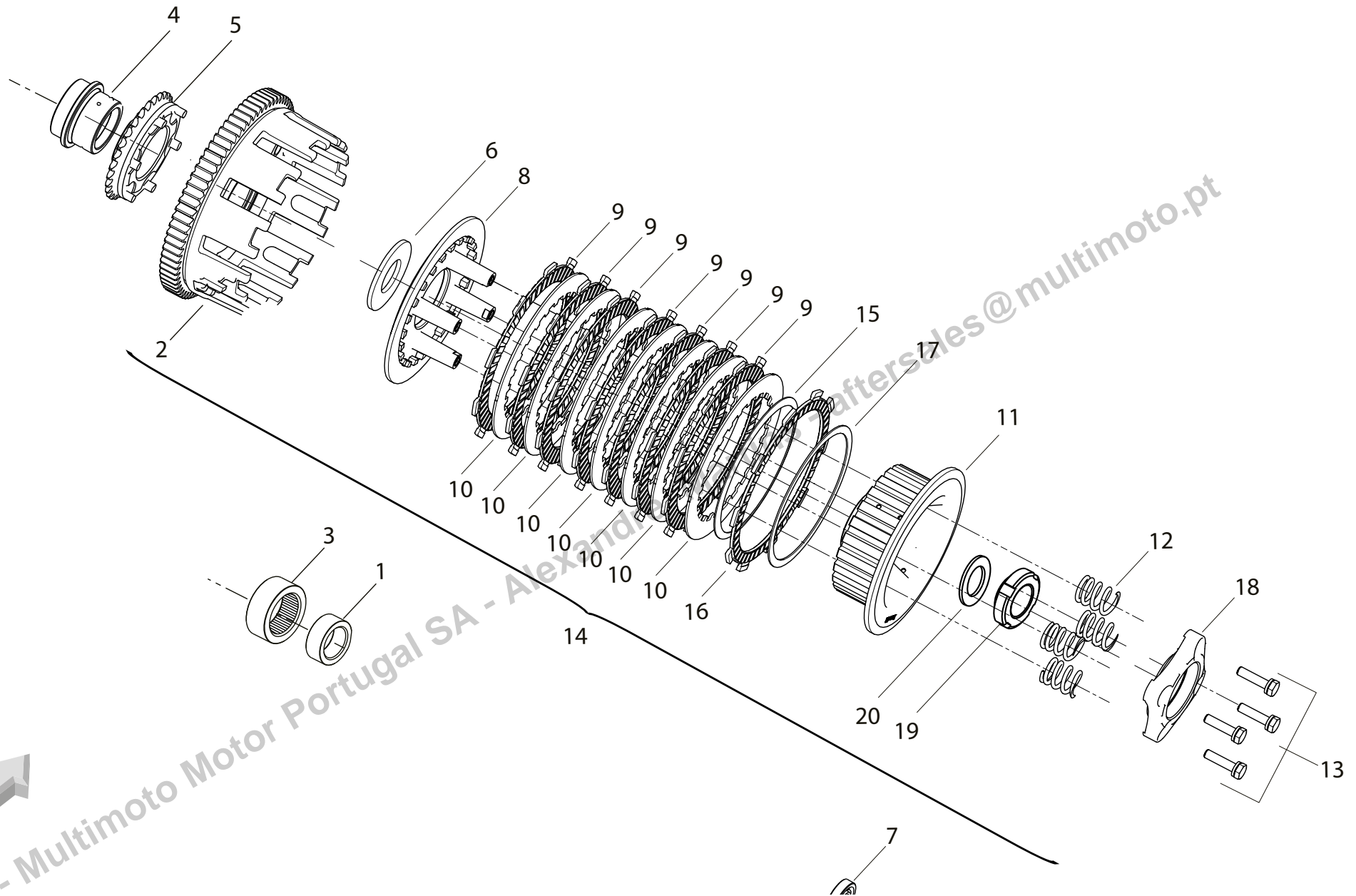

POS. NO. N. INDEX POS.	N. CODICE CODE NO. Nr. CODE ATRÍKEL Nr. CODICO Nr.	DESCRIZIONE	DESCRIPTION	DESIGNATION	BEZEICHNUNG	DENOMINACION	NOTE NOTES NOTES MARKE NOTAS	Q.TA' CONF. Q.TY PACK. Q.TE EMB. M.GE PAK. C.AD PAQ.	
1	200176030001	BOCCOLA DI GUIDA	BUSH OF GUIDE	DOUILLE DE GUIDE	BUCHSE DES GUIDE	CASQUILLO DE GUÍA		1	
2	209016280020	CAMPANA FRIZIONE	CLUTCH HOUSING	CLOCHE EMBRAYAGE	KUPPLUNGSGLOCKE	CAMPANA EMBRAGUE		1	
3	200476030000	CUSCINETTO A RULLI	BEARING, NEEDLE	ROULEMENT À ROULEAUX	ROLLENLAGER	COJINETE DE RODIL		1	
4	210146280000	DISTANZIALE	SPACER	ENTRETOISE	DISTANZSTÜCK	DISTANCIAL		1	
5	269116030000	PIGNONE POMPA OLIO	OIL PUMP SPROCKET	PIGNON POMPE A HUILE	RITZEL, OELPUMPE	PIÑÓN BOMBA ACEITE		1	
6	R320052266000	RONDELLA	WASHER	RONDELLE	UNTERLEGSCHIBE	ARANDELA		1	
7	B12016600401	CUSCINETTO	BEARING	ROULEMENT	LAGER	COJINETE		1	
8	200306030001	PIATTO SPINGIDISCO	DISC PRESSURE PLATE	PLAT POUSSÉ-DISQUE	PLATTE SCHEIBENDRÜCKER	PLACA EMPUJA-DISCO		1	
9	R320024126000	DISCO FRIZIONE CONDOTTO	DRIVEN CLUTCH PLATE	DISQUE D'EMBRAYAGE ENTRAÎNÉ	ANGETRIEBENES KUPPLUNGPLATTE	DISCO EMBRAGUE CONDUCIDO		1	
10	200216030000	DISCO FRIZIONE ACCIAIO	STEEL CLUTCH PLATE	DISQUE D'EMBRAYAGE EN ACIER	STAHLKUPPLUNG PLATTE	DISCO EMBRAGUE DE ACERO		1	
11	200206030001	TAMBURO FRIZIONE	CLUTCH DRUM	TAMBOUR EMBRAYAGE	KUPPLUNGSTROMMEL	TAMBOR EMBRAGUE		1	
12	R320052221000	MOLLA FRIZIONE	CLUTCH SPRING	RESSORT EMBRAYAGE	KUPPLUNGSFEDER	MUELLE EMBRAGUE		1	
13	R320052180000	VITE (M6X25)	SCREW (M6X25)	VIS (M6X25)	SHRAUBE (M6X25)	TORNILLO (M6X25)		1	
14	209106280010	FRIZIONE COMPLETA	COMPLETE CLUTCH	EMBRAYAGE COMPLET	KUPPLUNG KOMPLETT	EMBRAGUE COMPLETA		1	
15	R320052222000	MOLLA A TAZZA	SPRING WASHER	BELLEVILLE	TELLERFEDER	ARANDELA DE MUELLE		1	
16	R320424127000	DISCO FRIZIONE CONDOTTO SP. 9	DRIVEN CLUTCH PLATE SP. 9	DISQUE D'EMBRAYAGE ENTRAÎNÉ SP. 9	ANGETRIEBENES KUPPLUNGPLATTE SP. 9	DISCO EMBRAGUE CONDUCIDO SP. 9		1	
17	200236030001	GUARNIZIONE	GASKET	GARNITURE	DICHTUNG	JUNTA		1	
18	R320001007000	FLANGIA	FLANGE	BRIDE	FLANSCH	BRIDA		1	
19	210166030101	DADO AD INTAGLI (M20)	NUT CROWN (M20)	ECROU CRENELE (M20)	KRONENMUTTER (M20)	TUERCA ENTALLADA (M20)		1	
20	210156030001	RONDELLA	WASHER	RONDELLE	UNTERLEGSCHIBE	ARANDELA		1	

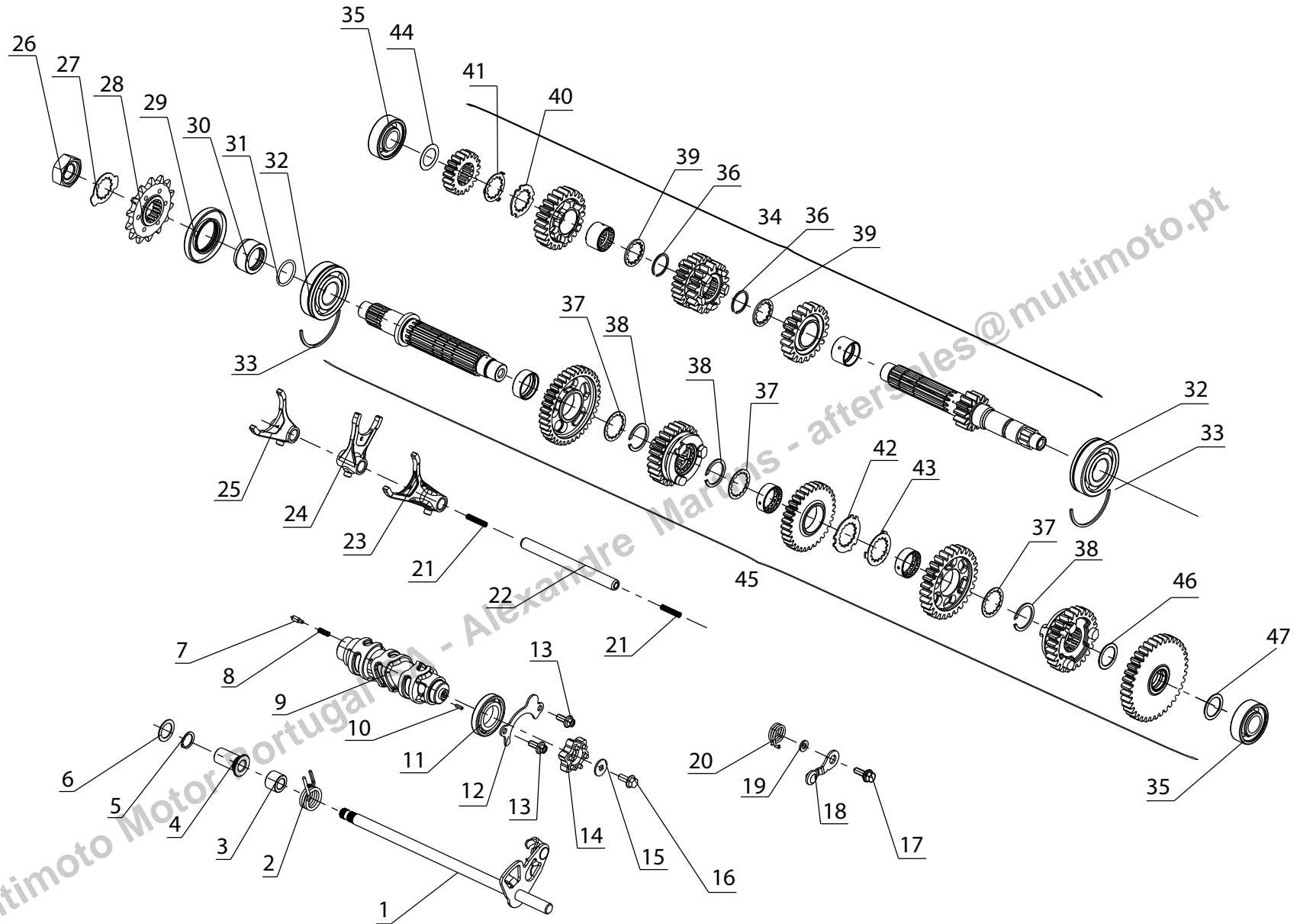

SSMT

POS. NO. N. INDEX POS.	N. CODICE CODE NO. Nr. CODE ATRÍKEL Nr. CODICO Nr.	DESCRIZIONE	DESCRIPTION	DESIGNATION	BEZEICHNUNG	DENOMINACION	NOTE NOTES NOTES MARKE NOTAS	Q.TA' CONF. Q.TY PACK. Q.TE EMB. M.GE PAK. C.AD PAQ.	
1	219066280000	ALBERO SELETTORE	SHIFT SHAFT ASSY	ARBRE SELECTEUR	SCHALTWELLE	ARBOL SELECTOR		1	
2	210056030000	MOLLA ARRESTO MARCE	GEAR STOP SPRING	RESSORT ARRÊT VITESSES	GANGSTOPPFEDER	MUELLE ARRESTO CAMBIO		1	
3	210046030000	DISTANZIALE	SPACER	ENTRETOISE	DISTANZSTÜCK	DISTANCIAL		1	
4	210396030000	BOCCOLA	BUSH	DOUILLE	BUCHSE	CASQUILLO		1	
5	B08010001701	ANELLO ELASTICO	SNAP RING	BAGUE ÉLASTIQUE	SPRENGRING	SEAGER		1	
6	210406030000	RASAMENTO	SHIM	ROSETTE DE BUTÉE	DISTANZSCHEIBE	ARANDELA DE ESPESORACIÓN		1	
7	210323090000	SPINA	PIN	GOUPILLE	STIFT	PASADOR		1	
8	R320052218000	MOLLA	SPRING	RESSORT	FEDER	MUELLE		1	
9	R320025062000	DESMODROMICO	SHIFT CAM	DESMODROMIQUE	VERSCHIEBENOCKE	DESMO		1	
10	R320052251000	PIOLO	PIN	PIVOT	STIFT	ESPINA		1	
11	R320052210000	CUSCINETTO	BEARING	ROULEMENT	LAGER	COJINETE		1	
12	R320057078000	PIASTRINO	PLATE	PLAQUETTE	PLÄTTCHEN	LÁMINA		1	
13	R320452172000	VITE (M6X14)	SCREW (M6X14)	VIS (M6X14)	SHARAUBE (M6X14)	TORNILLO (M6X14)		1	
14	210366030000	TAMBURO CAMBIO	GEARBOX DRUM	TAMBOUR BOÎTE DE VITESSES	SCHALTTROMMEL	TAMBOR CAMBIO		1	
15	R320052261000	RONDELLA	WASHER	RONDELLE	UNTERLEGSCHIEBE	ARANDELA		1	
16	R320052173000	VITE (M6X15)	SCREW (M6X15)	VIS (M6X15)	SHARAUBE (M6X15)	TORNILLO (M6X15)		1	
17	R320452162000	VITE	SCREW	VIS	SCHRAUBE	TORNILLO		1	
18	R320425047000	SALTARELLO FISSA MARCE	GEAR STOPPER	CLIQUET FIXE-VITESSES	FALLKLINKEN	TRINQUETE FIJA MARCHAS		1	
19	210343090000	RONDELLA	WASHER	RONDELLE	UNTERLEGSCHIEBE	ARANDELA		4	
20	R320452047000	MOLLA BILANCIERE	SPRING ROCKER	RESSORT CULBUTEUR	KIPPEBEL VERTEILER	MUELLE BILANCÍN		1	
21	R320052220000	MOLLA	SPRING	RESSORT	FEDER	MUELLE		1	
22	R320052249000	PERNO	PIN	PIVOT	ZAPFEN	PERNO		1	
23	R320025032000	FORCELLA INNESTO MARCE 5 ^a /6 ^a	5TH, 6TH GEAR SELECTOR FORK	FOURCHE ENGRÈNEMENT 5ÈME, 6ÈME VITESSE	EINLEGGABEL FÜR 5 ^a /6 ^a GANG	HORQUILLA EMBRAGUE 5 ^a /6 ^a		1	
24	R320025031000	FORCELLA INNESTO MARCE 5 ^a /6 ^a	5TH, 6TH GEAR SELECTOR FORK	FOURCHE ENGRÈNEMENT 5ÈME, 6ÈME VITESSE	EINLEGGABEL FÜR 5 ^a /6 ^a GANG	HORQUILLA EMBRAGUE 5 ^a /6 ^a		1	



POS. NO. N. INDEX POS.	N. CODICE CODE NO. Nr. CODE ATRIBEL Nr. CODICO Nr.	DESCRIZIONE	DESCRIPTION	DESIGNATION	BEZEICHNUNG	DENOMINACION	NOTE NOTES NOTES MARKE NOTAS	Q.TA' CONF. Q.TY PACK. Q.TE EMB. M.GE PAK. C.AD PAQ.	
25	R320025030000	FORCELLA INNESTO MARCE 1 ^o /4 ^a -2 ^o /3 ^a	1ST, 4TH-2ND, 3RD GEAR SELECTOR FORK	FOURCHE ENGRÈNEMENT 1ÈRE, 4ÈME-2ÈME, 3ÈME VITESSE	EINLEGGABEL FÜR 1 ^o /4 ^a -2 ^o /3 ^a GANG	HORQUILLA EMBRAGUE MARCHAS 1 ^o /4 ^a -2 ^o /3 ^a		1	
26	210196030000	DADO (M18)	NUT (M18)	ECROU (M18)	MUTTER (M18)	TUERCA (M18)		1	
27	210306030000	RONDELLA	WASHER	RONDELLE	UNTERLEGSCHLEIBE	ARANDELA		1	
28	219296030000	PIGNONE	SPROCKET	PIGNON	RITZEL	PIÑÓN		1	
29	210216030010	PARAOILIO	OIL SEAL	BAGUE D'ETANCHEITE	WELLENDICHRING	RETEN DE ACEITE		1	
30	210206030000	BUSSOLA BROCCIATA	BROACHED BUSH	DOUILLE BROCHEE	RÄUMBUCHSE	CASQUILLO RANURADA		1	
31	210316030000	GUARNIZIONE O-RING	O-RING	JOINT D'ÉTANCHÉITÉ	DICHTUNG O-RING	JUNTA OR		1	
32	210136030010	CUSCINETTO	BEARING	ROULEMENT	LAGER	COJINETE		1	
33	R320004086000	FERMO CUSCINETTO	BEARING LOCK	ARRÊT ROULEMENT	STILLSTAND LAGER	SEGURO COJINETE		1	
34	219136280000	ALBERO PRIMARIO COMPLETO	COMPLETE MAIN SHAFT	ARBRE PRIMAIRE COMPLET	KOMPLETTE HAUPTWELLE	ARBOL PRIMARIO COMPLETO		1	
35	R320052211000	CUSCINETTO	BEARING	ROULEMENT	LAGER	COJINETE		1	
36	R320052205000	ANELLO ELASTICO	SNAP RING	BAGUE ÉLASTIQUE	SPRENGRING	SEAGER		1	
37	R320052253000	RASAMENTO	SHIM	ROSETTE DE BUTÉE	DISTANZSCHEIBE	ARANDELA DE ESPESORACIÓN		1	
38	R320052206000	ANELLO ELASTICO	SNAP RING	BAGUE ÉLASTIQUE	SPRENGRING	SEAGER		1	
39	R320052272000	RONDELLA AD INTAGLI	WASHER-CROWN	RONDELLE ENTAILLE	KRONENUNTERLEGSCHEIBE	ARANDELA ENTALLADA		1	
40	R320052271000	RONDELLA AD INTAGLI	WASHER-CROWN	RONDELLE ENTAILLE	KRONENUNTERLEGSCHEIBE	ARANDELA ENTALLADA		1	
41	R320052270000	RONDELLA AD INTAGLI	WASHER-CROWN	RONDELLE ENTAILLE	KRONENUNTERLEGSCHEIBE	ARANDELA ENTALLADA		1	
42	R320052273000	RONDELLA AD INTAGLI	WASHER-CROWN	RONDELLE ENTAILLE	KRONENUNTERLEGSCHEIBE	ARANDELA ENTALLADA		1	
43	R320052274000	RONDELLA AD INTAGLI	WASHER-CROWN	RONDELLE ENTAILLE	KRONENUNTERLEGSCHEIBE	ARANDELA ENTALLADA		1	
44	210566030010	GUARNIZIONE	GASKET	GARNITURE	DICHTUNG	JUNTA	Ø 30X20.3X0.4	1	
45	219216030000	ALBERO SECONDARIO COMPLETO	COMPLETE LAY SHAFT	ARBRE SECONDAIRE COMPLET	KOMPLETTE VORGELEGEWELLE	ARBOL SECUNDARIO COMPLETO		1	
46	R320052255000	RASAMENTO	SHIM	ROSETTE DE BUTÉE	DISTANZSCHEIBE	ARANDELA DE ESPESORACIÓN		1	
47	R320052269000	RONDELLA	WASHER	RONDELLE	UNTERLEGSCHLEIBE	ARANDELA		1	

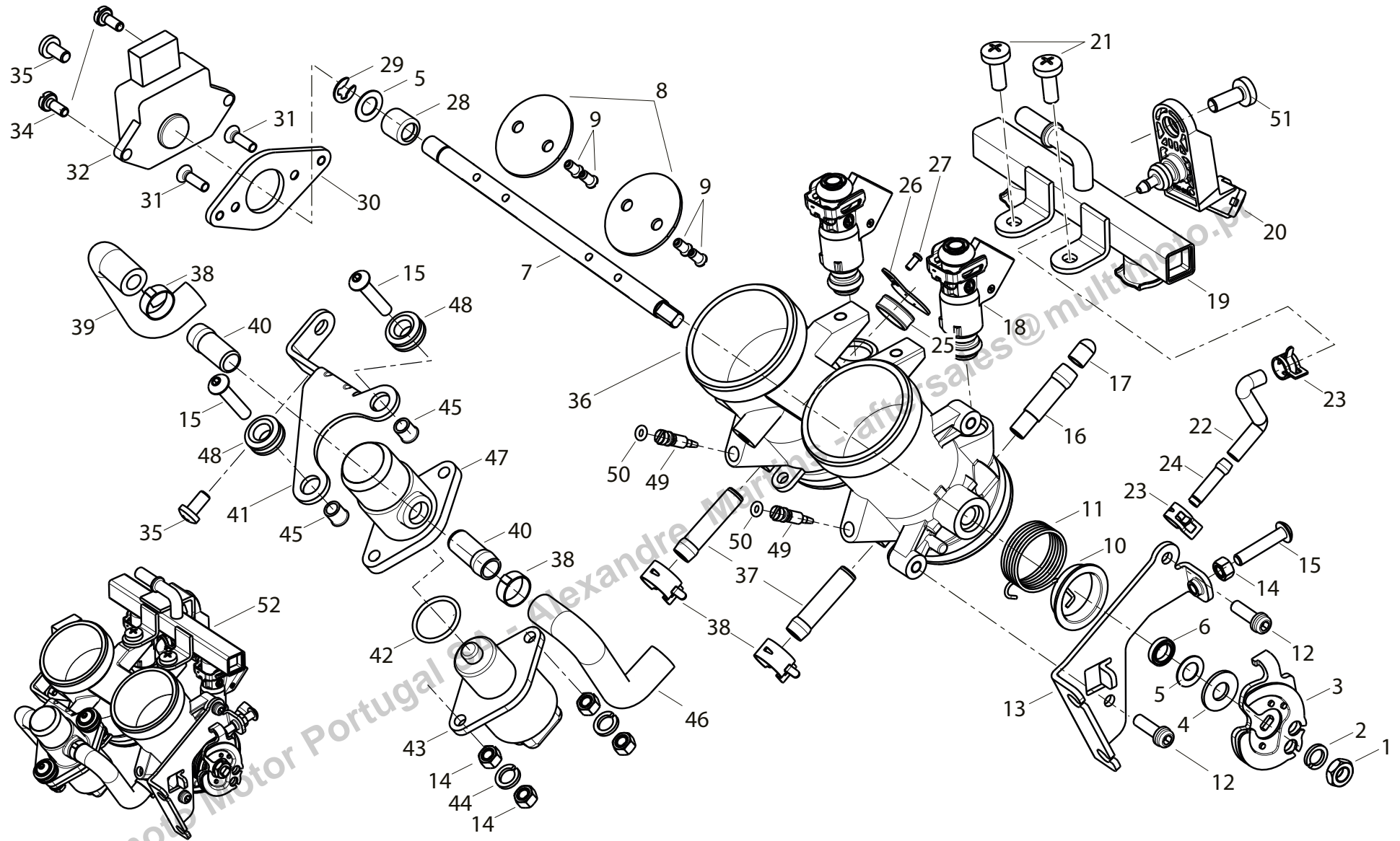

POS. NO. N. INDEX POS.	N. CODICE CODE NO. Nr. CODE ATRÍKEL Nr. CODICO Nr.	DESCRIZIONE	DESCRIPTION	DESIGNATION	BEZEICHNUNG	DENOMINACION	NOTE NOTES NOTES MARKE NOTAS	Q.TA' CONF. Q.TY PACK. Q.TE EMB. M.GE PAK. C.AD PAQ.	
1	280476090001	DADO (M7)	NUT (M7)	ECROU (M7)	MUTTER (M7)	TUERCA (M7)		1	
2	B0700000080A	RASAMENTO	SHIM	ROSETTE DE BUTÉE	DISTANZSCHEIBE	ARANDELA DE ESPESORACIÓN		1	
3	280676030000	FLANGIA	FLANGE	BRIDE	FLANSCH	BRIDA		1	
4	280346090000	RONDELLA	WASHER	RONDELLE	UNTERLEGSCHIEBE	ARANDELA		1	
5	280336090000	RONDELLA	WASHER	RONDELLE	UNTERLEGSCHIEBE	ARANDELA		1	
6	280386030000	PARAOILIO	OIL SEAL	BAGUE D'ETANCHEITE	WELLENDICHTRING	RETEN DE ACEITE		1	
7	280016220020	ALBERINO	SHAFT	ARBRE	WELLE	EJE		1	
8	280076030000	FLANGIA FARFALLA	FLANGE THROTTLE	BRIDE DE L'ACCELERATEUR	DROSSELFLANSCH	BRIDA DEL ACELERADOR		1	
9	280116080000	VITE	SCREW	VIS	SCHRAUBE	TORNILLO		1	
10	280196030000	BOCCOLA	BUSH	DOUILLE	BUCHSE	CASQUILLO		1	
11	280306030000	MOLLA	SPRING	RESSORT	FEDER	MUELLE		1	
12	B02000501029	VITE (M5X10)	SCREW (M5X10)	VIS (M5X10)	SCHRAUBE (M5X10)	TORNILLO (M5X10)		1	
13	280066220000	STAFFA	BRACKET	BRIDE	BÜGEL	SOPORTE		1	
14	B04000500059	DADO (M5)	NUT (M5)	ECROU (M5)	MUTTER (M5)	TUERCA (M5)		1	
15	B02000502529	VITE (M5X25)	SCREW (M5X25)	VIS (M5X25)	SCHRAUBE (M5X25)	TORNILLO (M5X25)		1	
16	280506030010	INSERTO	INSERT	INSERT	EISATZ	INSERTO		1	
17	3314302E0000	TAPPO	CAP	BOUCHON	VERSCHLUB	TAPÓN		1	
18	289026280000	INIETTORE	INJECTOR	INJECTEUR	EINSPRITZDÜSE	INJECTOR		1	
19	289086280010	FLAUTO INIETTORI	FUEL RAIL	FUEL RAIL	FUEL RAIL	FUEL RAIL		1	
20	289066280000	SENSORE MAP	MAP SENSOR	CAPTEUR MAP	SENSOR MAP	SENSOR MAP		1	
21	B02040501629	VITE (M5X16)	SCREW (M5X16)	VIS (M5X16)	SHARAUBE (M5X16)	TORNILLO (M5X16)		1	
22	289076280000	TUBO	TUBE	TUBE	ROHR	TUBO		1	
23	490167030000	MOLLETTA PASSATUBO	HOSE GUIDE SPRING	RESSORT PASSE-TUBE	FEDER LEITUNGSFÜHRUNG	PASADOR PASATUBO		1	
24	3313701K0000	INSERTO	INSERT	INSERT	EISATZ	INSERTO		1	



POS. NO. N. INDEX POS.	N. CODICE CODE NO. Nr. CODE ATRÍKEL Nr. CODICO Nr.	DESCRIZIONE	DESCRIPTION	DESIGNATION	BEZEICHNUNG	DENOMINACION	NOTE NOTES NOTES MARKE NOTAS	Q.TA' CONF. Q.TY PACK. Q.TE EMB. M.GE PAK. C.AD PAQ.	
25	280686030000	ANELLO DI TENUTA	SEAL RING	BAGUE D'ÉTANCHÉITÉ	DICHTRING	ANILLO DE RETÉN		1	
26	280576030000	PIASTRINO	PLATE	PLAQUETTE	PLÄTTCHEN	LÁMINA		1	
27	B02000300829	VITE (M3X8)	SCREW (M3X8)	VIS (M3X8)	SCHRAUBE (M3X8)	TORNILLO (M3X8)		1	
28	280116090000	CUSCINETTO A RULLI	BEARING NEEDLE	ROULEMENT À ROULEAUX	ROLLENLAGER	COJINETE DE RODILLOS		1	
29	280249010000	ANELLO SEEGER	CIRCLIP	CIRCLIP	SEEGERRING	ANILLO SEEGER		1	
30	R320057092000	PIASTRINO	PLATE	PLAQUETTE	PLÄTTCHEN	LÁMINA		1	
31	R170052045000	VITE (M4X12)	SCREW (M4X12)	VIS (M4X12)	SCHRAUBE (M4X12)	TORNILLO (M4X12)		1	
32	280756030010	POTENZIOMETRO	POTENTIOMETER	POTENTIOMÈTRE	POTENTIOMETER	POTENCIÓMETRO		1	
33	R999999999999	RONDELLA	WASHER	RONDELLE	UNTERLEGSCHIEBE	ARANDELA		1	
34	B1308040102H	VITE (M4X10)	SCREW (M4X10)	VIS (M4X10)	SCHRAUBE (M4X10)	TORNILLO (M4X10)		1	
35	B02000501429	VITE (M5X14)	SCREW (M5X14)	VIS (M5X14)	SCHRAUBE (M5X14)	TORNILLO (M5X14)		1	
36	289066220000	CORPO FARFALLATO	THROTTLE BODY	CORPS À PAPILLON	DROSSELKÖRPER	CUERPO MARIPOSA		1	
37	280716030000	TUBO	TUBE	TUBE	ROHR	TUBO		1	
38	06103N140000	FASCETTA	CLAMP	COLLIER	SHELLE	ABRAZADERA		1	
39	280946030000	TUBO	TUBE	TUBE	ROHR	TUBO		1	
40	280956030000	TUBO	TUBE	TUBE	ROHR	TUBO		1	
41	R320057080000	PIASTRINO SPECIALE	SPECIAL PLATE	PLAQUETTE SPÉCIALE	SPEZIALPLÄTTCHEN	LÁMINA ESPECIAL		1	
42	R92850089M	GUARNIZIONE O-RING	O-RING	JOINT D'ÉTANCHÉITÉ	DICHTUNG O-RING	JUNTA OR		1	
43	280476030020	MOTORINO PASSO PASSO	STEPPER MOTOR	MOTEUR PAS-À-PAS	SCHRITTMOTOR	MOTOR PASO PASO		1	
44	B07000000509	RONDELLA SPECIALE	SPECIAL WASHER	RONDELLE SPÉCIALE	SPEZIALUNTERLEGSCHIEBE	ARANDELA ESPECIAL		1	
45	280976030000	BOCCOLA	BUSH	DOUILLE	BÜCHSE	CASQUILLO		1	
46	280936030000	TUBO	TUBE	TUBE	ROHR	TUBO		1	
47	280966030000	DISTRIBUTORE	TIMING SYSTEM	DISTRIBUTEUR	VERTEILER	DISTRIBUIDOR		1	
48	R030486025000	GOMMINO ANTIVIBRANTE	VIBRATION DAMPER PAD	JOINT EN CAOUTCHOUC ANTI-VIBRATION	SCHWINGUNGSDÄMPFERGUMMI	JUNTA DE GOMA ANTI-VIBRACIÓN		3	

POS. NO. N. INDEX POS.	N. CODICE CODE NO. Nr. CODE ATRÍKEL Nr. CODICO Nr.	DESCRIZIONE	DESCRIPTION	DESIGNATION	BEZEICHNUNG	DENOMINACION	NOTE NOTES NOTES MARKE NOTAS	Q.TA' CONF. Q.TY PACK. Q.TE EMB. M.GE PAK. C.AD PAQ.	
49	280406090000	VITE	SCREW	VIS	SCHRAUBE	TORNILLO		1	
50	280416090000	GUARNIZIONE O-RING	O-RING	JOINT D'ÉTANCHÉITÉ	DICHTUNG O-RING	JUNTA OR		1	
51	R320052177000	VITE (M6X12)	SCREW (M6X12)	VIS (M6X12)	SHARAUBE (M6X12)	TORNILLO (M6X12)		1	
52	289006280010	CORPO FARFALLATO COMPLETO	THROTTLE BODY COMPLETE	CORPS A' PAPILLON COMPLET	DROSSELKÖRPER KOMPLETTE	CUERPO MARIPOSA COMPLETO		1	



Multimoto Motor Portugal SA - Alexandre Martins - aftersales@multimoto.pt

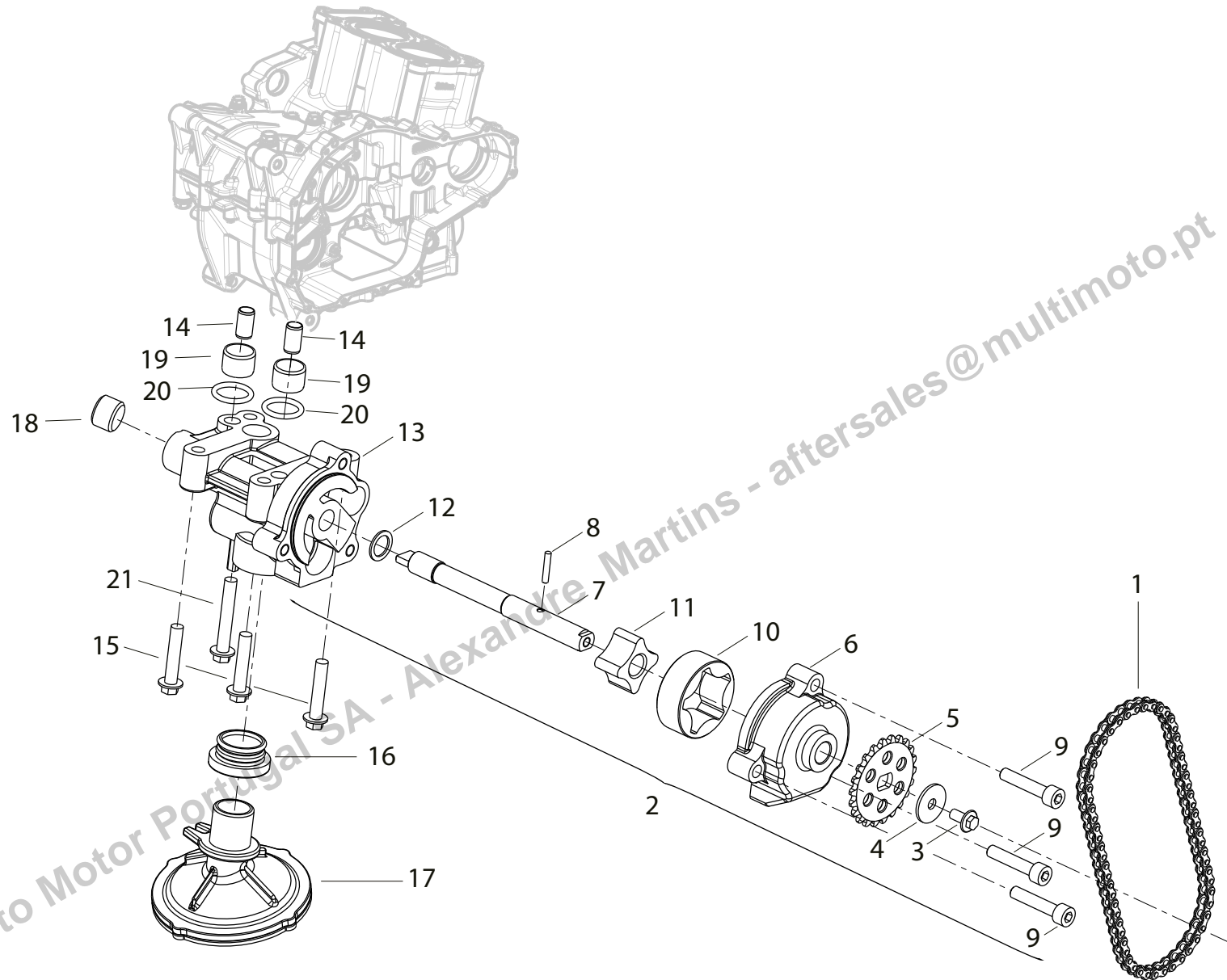

POS. NO. N. INDEX POS.	N. CODICE CODE NO. Nr. CODE ATRIBEL Nr. CODICO Nr.	DESCRIZIONE	DESCRIPTION	DESIGNATION	BEZEICHNUNG	DENOMINACION	NOTE NOTES NOTES MARKE NOTAS	Q.TA' CONF. Q.TY PACK. Q.TE EMB. M.GE PAK. C.AD PAQ.	
1	R320006044000	CATENA POMPA OLIO	OIL PUMP CHAIN	CHAÎNE POMPE À HUILE	KETTE ÖELPUMPE	CADENA BOMBA DE ACEITE		1	
2	269016280000	POMPA OLIO COMPLETA	COMPLETE OIL PUMP	POMPE À HUILE COMPLET	ÖLPUMPE KOMPLETT	BOMBA ACEITE COMPLETA		1	
3	R320452167000	VITE (M5X10)	SCREW (M5X10)	VIS (M5X10)	SCHRAUBE (M5X10)	TORNILLO (M5X10)		1	
4	R320052258000	RONDELLA	WASHER	RONDELLE	UNTERLEGSSCHEIBE	ARANDELA		1	
5	R320406026000	PIGNONE POMPA OLIO	OIL PUMP SPROCKET	PIGNON POMPE A HUILE	RITZEL, OELPUMPE	PIÑÓN BOMBA ACEITE		1	
6	R320401117000	COPERCHIO POMPA OLIO	OIL PUMP COVER	COUVERCLE POMPE À HUILE	OELPUMPEDECKEL	TAPA BOMBA DE ACEITE		1	
7	269036280000	ALBERO POMPA OLIO	OIL PUMP SHAFT	ARBRE POMPE À HUILE	WELLE ÖLPUMPE	ÁRBOL BOMBA ACEITE		1	
8	B090103016B0	PIOLO	PIN	PIVOT	STIFT	ESPINA		1	
9	R020051134000	VITE (M6X30)	SCREW (M6X30)	VIS (M6X30)	SHARAUBE (M6X30)	TORNILLO (M6X30)		1	
10	R320407045000	ROTORE ESTERNO	OUTER ROTOR	EXTERNE ROTORS	ROTOREN DECKEL	ROTOR EXTERIOR		1	
11	R320407046000	ROTORE INTERNO	INNER ROTOR	INTERNE ROTORS	ROTOREN INNERES	ROTOR INTERIOR		1	
12	R320052263000	RONDELLA	WASHER	RONDELLE	UNTERLEGSSCHEIBE	ARANDELA		1	
13	269026280000	CORPO POMPA OLIO	OIL PUMP BODY	CORPS POMPE HUILE	KÖRPER ÖLPUMPE	CUERPO BOMBA ACEITE		1	
14	160073070000	BOCCOLA	BUSH	DOUILLE	BUCHSE	CASQUILLO		1	
15	B01070603264	VITE (M6X32)	SCREW (M6X32)	VIS (M6X32)	SHARAUBE (M6X32)	TORNILLO (M6X32)		1	
16	R320013277000	RACCORDO FILTRO ASPIRAZIONE	QUICK-COUPLING UNION	RACCORD RAPIDE	STECKANSCHLUß	CONEXIÓN RÁPIDA		1	
17	R320401033000	FILTRO ASPIRAZIONE	INTAKE FILTER	FILTRE ASPIRATION	ANSAUGFILTER	FILTRO ASPRACIÓN		1	
18	100066090000	TAPPO FILETTATO	THREADED CAP	BOUCHON FILETÉE	GEWINDE VERSCHLUß	TAPÓN FILETEADO		1	
19	269136280000	SPINA	PIN	GOUPILLE	STIFT	PASADOR		1	
20	160085040000	GUARNIZIONE O-RING	O-RING	JOINT D'ÉTANCHÉITÉ	DICHTUNG O-RING	JUNTA OR		1	
21	R030652064000	VITE (M6X40)	SCREW (M6X40)	VIS (M6X40)	SHARAUBE (M6X40)	TORNILLO (M6X40)		2	



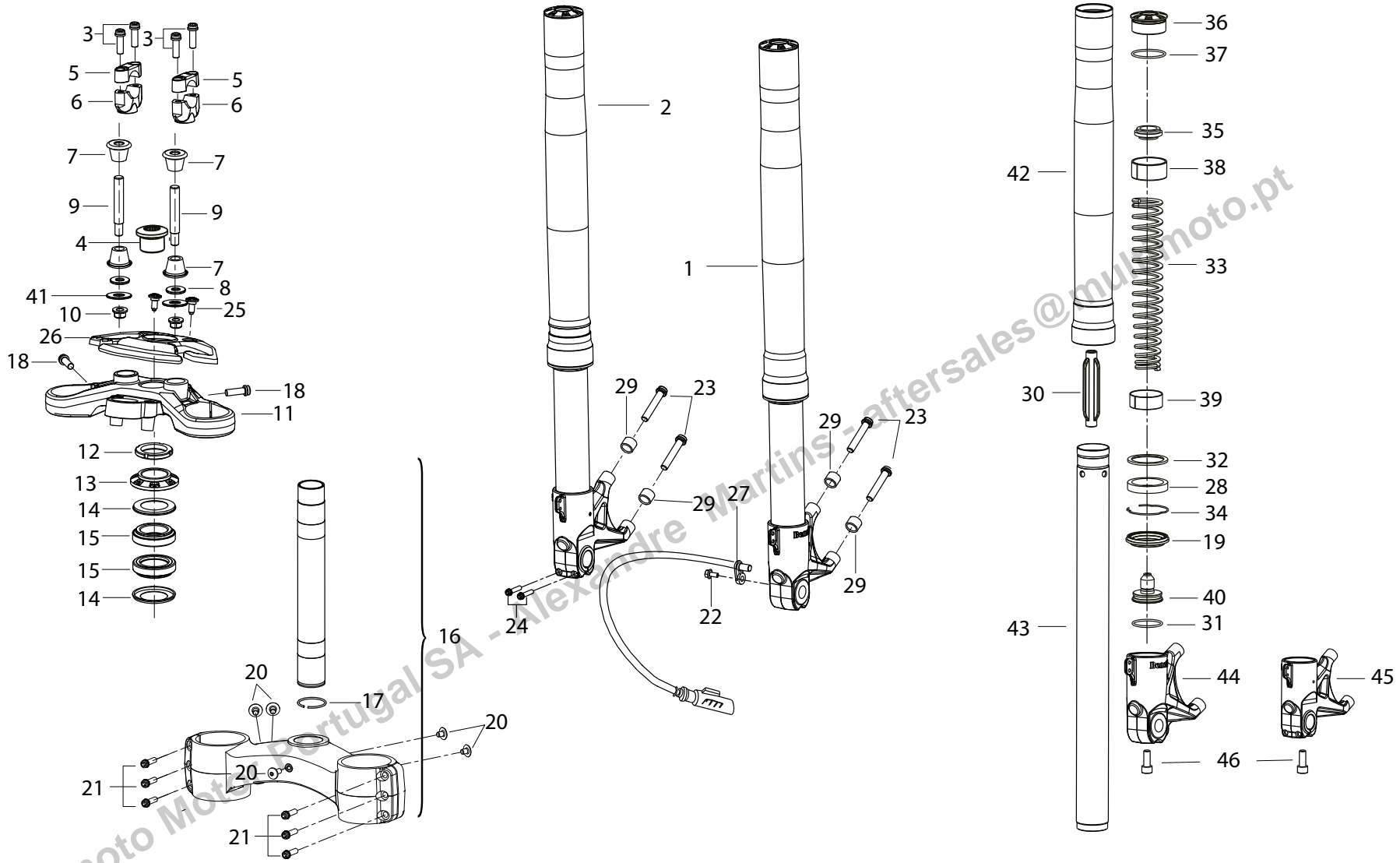

POS. NO. N. INDEX POS.	N. CODICE CODE NO. Nr. CODE ATRINKEL Nr. CODICO Nr.	DESCRIZIONE	DESCRIPTION	DESIGNATION	BEZEICHNUNG	DENOMINACION	NOTE NOTES NOTES MARKE NOTAS	Q.TA' CONF. Q.TY PACK. Q.TE EMB. M.GE PAK. C.AD PAQ.	
1	43200P160100	ASSIEME GAMBA SINISTRA (RADIALE)	L.H. FORK LEG ASSEMBLY (RADIAL)	ENSEMBLE FOURCHE GAUCHE (RADIAL)	LINKES FEDERBEIN KOMPLETT (RADIAL)	TUBO HORQUILLA IZQ. (RADIAL)		1	
2	43300P160100	ASSIEME GAMBA DESTRA (RADIALE)	R.H. FORK LEG ASSEMBLY (RADIAL)	ENSEMBLE FOURCHE DROITE (RADIAL)	RECHTES FEDERBEIN KOMPLETT (RADIAL)	TUBO HORQUILLA DERECHA (RADIAL)		1	
3	B0281080256H	VITE (M8X25)	SCREW (M8X25)	VIS (M8X25)	SHARAUBE (M8X25)	TORNILLO (M8X25)		1	
4	43049P250000	VITE SPECIALE	SPECIAL SCREW	VIS SPÉCIALE	SPEZIALSCHRAUBE	TORNILLO ESPECIAL		1	
5	43013P010101	COPPIA CAVALLOTTI	UPPER BRACKET	CAVALIER SUPÉRIEURE	BÜGELBOLZEN OBERER	PERNO DE U SUPERIOR		1	
6	43014P010100	CAVALLOTTO INFERIORE	LOWER BRACKET	CAVALIER INFÉRIEURE	BÜGELBOLZEN UNTERER	PERNO DE U INFERIOR		1	
7	47015P010000	SILENT-BLOCK MANUBRIO	HANDLEBAR SILENT-BLOCK	GUIDON SILENT BLOCK	LENKER SILENT-BLOCK	MANILLAR SILENT BLOCK		1	
8	40089P010100	RONDELLA	WASHER	RONDELLE	UNTERLEGSCHIEBE	ARANDELA		1	
9	40086P010002	PRIGIONIERO	STUD BOLT	GOUJON	STIFTSCHRAUBE	TORNILLO SIN FIN		1	
10	R91350091B	DADO (M10)	NUT (M10)	ECROU (M10)	MUTTER (M10)	TUERCA (M10)		1	
11	43011P160000	BASE DI STERZO SUPERIORE	UPPER STEERING HEAD BASE	BASE DE DIRECTION SUPERIEURE	GABELKOPF OBERE	TIJA CABEZA DIRECCIÓN SUPERIOR		1	
12	R90752321A	GHIERA PERNO DI STERZO	STEERING RING NUT PIN	BAGUE PIVOT DE DIRECTION	LENKUNGSSAPFEN-NUTMUTTER	ZUNCHO PERNO DE DIRECCIÓN		1	
13	43009P260000	GHIERA DI STERZO	STEERING RING NUT	BAGUE DE DIRECTION	LENKUNGSSAPFEN	ZUNCHO DE DIRECCIÓN		1	
14	43005S010000	ANELLO PARAPOLVERE	RING,PROTECTION DUST	BAGUE PARE POUSSIERE	DICHTRING STAUBSCHUTZ	ANILLO GUARDAPOLVO		1	
15	43130S010000	CUSCINETTO	BEARING	ROULEMENT	LAGER	COJINETE		1	
16	43100P160000	BASE DI STERZO INFERIORE	LOWER STEERING HEAD BASE	BASE DE DIRECTION INFERIEUR	GABELKOPF UNTEN	TIJA CABEZA DIRECCIÓN INFERIOR		1	
17	R320052045000	ANELLO SEEGER	CIRCLIP	CIRCLIP	SEEGERRING	ANILLO SEEGER		1	
18	R90751451B	VITE (TCEI M8X25)	SCREW (TCEI M8X25)	VIS (TCEI M8X25)	SHARAUBE (TCEI M8X25)	TORNILLO (TCEI M8X25)		1	
19	43290P250000	PARAPOLVERE	SEAL,DUST	PARE POUSSIERE	STAUBDECKEL	GUARDAPOLVO		1	
20	R320052046000	VITE (M6X8)	SCREW (M6X8)	VIS (M6X8)	SHARAUBE (M6X8)	TORNILLO (M6X8)		1	
21	R90750531B	VITE (M6X25)	SCREW (M6X25)	VIS (M6X25)	SHARAUBE (M6X25)	TORNILLO (M6X25)		5	
22	R320052145000	VITE (M6X12)	SCREW (M6X12)	VIS (M6X12)	SHARAUBE (M6X12)	TORNILLO (M6X12)		1	
23	08029P250000	VITE (M10X1.25X57)	SCREW (M10X1.25X57)	VIS (M10X1.25X57)	SCHRAUBE (M10X1.25X57)	TORNILLO (M10X1.25X57)		1	
24	R90750531B	VITE (M6X30)	SCREW (M6X30)	VIS (M6X30)	SHARAUBE (M6X30)	TORNILLO (M6X30)		1	



POS. NO. N. INDEX POS.	N. CODICE CODE NO. Nr. CODE ATRIBEL Nr. CODICO Nr.	DESCRIZIONE	DESCRIPTION	DESIGNATION	BEZEICHNUNG	DENOMINACION	NOTE NOTES NOTES MARKE NOTAS	Q.TA' CONF. Q.TY PACK. Q.TE EMB. M.GE PAK. C.AD PAQ.	
25	B0284060200A	VITE (M6X20)	SCREW (M6X20)	VIS (M6X20)	SHARAUBE (M6X20)	TORNILLO (M6X20)		1	
26	43012P160000	COPERCHIO	COVER	COUVERCLE	DECKEL	TAPA		1	
27	45710P250000	SENSORE DI VELOCITÀ ABS RUOTA ANTERIORE	FRONT WHELL SENSOR ABS	CAPTEUR VITESSE ABS ROUE AVANT	SENSOR GESCHWINDIGKEIT ABS VORDERRAD	SENSOR VELOCIDAD RUEDA DELANTERA ABS		1	
28	43260P250000	PARAOILIO	OIL SEAL	BAGUE D'ÉTANCHEITE	WELLENDICHTRING	RETEN DE ACEITE		1	
29	130015090000	DISTANZIALE	SPACER	ENTRETOISE	DISTANZSTÜCK	DISTANCIAL		1	
30	43609P130000	GUIDA MOLLA	SPRING GUIDE	GUIDE-RESSORT	GABELFEDERFÜHRUNG	GUIA MUELLE		1	
31	B190104100B0	GUARNIZIONE O-RING	O-RING	JOINT D'ÉTANCHÉITÉ	DICHTUNG O-RING	JUNTA OR		1	
32	43521P010000	RONDELLA	WASHER	RONDELLE	UNTERLEGSCHIEBE	ARANDELA		1	
33	43202P160000	MOLLA	SPRING	RESSORT	FEDER	MUELLE		1	
34	43523P010000	CLIP FISSAGGIO RAPIDO	QUIK FASTENING	FIXATION RAPIDE	SCHNELLEBEFESTIGUNG	FIJACIÓN RÁPIDA		1	
35	43234P100010	BOCCOLA	BUSH	DOUILLE	BUCHSE	CASQUILLO		1	
36	43204P160000	TAPPO FORCELLA	FRONT FORK CAP	BOUCHON FOURCHE	TELEGABELVERSCHLÜß	TAPÓN HORQUILLA		1	
37	B190104870B0	GUARNIZIONE O-RING	O-RING	JOINT D'ÉTANCHÉITÉ	DICHTUNG O-RING	JUNTA OR		1	
38	43212P300000	BOCCOLA SUPERIORE	UPPER BUSH	DOUILLE SUPÉRIEURE	ÖBERER BUCHSE	CASQUILLO SUPERIOR		1	
39	43239P010000	BOCCOLA INFERIORE	LOWER BUSH	DOUILLE INFÉRIEURE	UNTERER BUCHSE	CASQUILLO INFERIOR		1	
40	43681P160000	VALVOLA INFERIORE	LOWER VALVE	SOUPAPE INFÉRIEURE	UNTERER VENTIL	VÁLVULA INFERIOR		1	
41	08021P250000	ROSETTA	WASHER	ROSETTE	UNTERLEGSCHIEBE	ARANDELA		1	
42	43201P160100	FODERO FORCELLA	PIPE FORK	DOUBLURE DE FOURCHE	GABEL TAUCHROHR	FORRO DE HORQUILLA		1	
43	43231P160001	STELO FORCELLA	FORK TUBE	TUBE DE FOURCHE	GABELSTANGE	TUBO HORQUILLA		1	
44	43321P160000	PIEDINO FORCELLA ANTERIORE DESTRO	R.H. FOOT FRONT FORK	PIED FOURCHE AVANT DROITE	FÜßGABEL VORNE RECHTS	PIE DE HORQUILLA DELANTERA DER.		1	
45	43221P160000	PIEDINO FORCELLA ANTERIORE SINISTRO	L.H. FOOT FRONT FORK	PIED FOURCHE AVANT GAUCHE	FÜßGABEL VORNE LINKS	PIE DE HORQUILLA DELANTERA IZQ.		1	
46	B02051002553	VITE (M10X25)	SCREW (M10X25)	VIS (M10X25)	SCHRAUBE (M10X25)	TORNILLO (M10X25)		1	

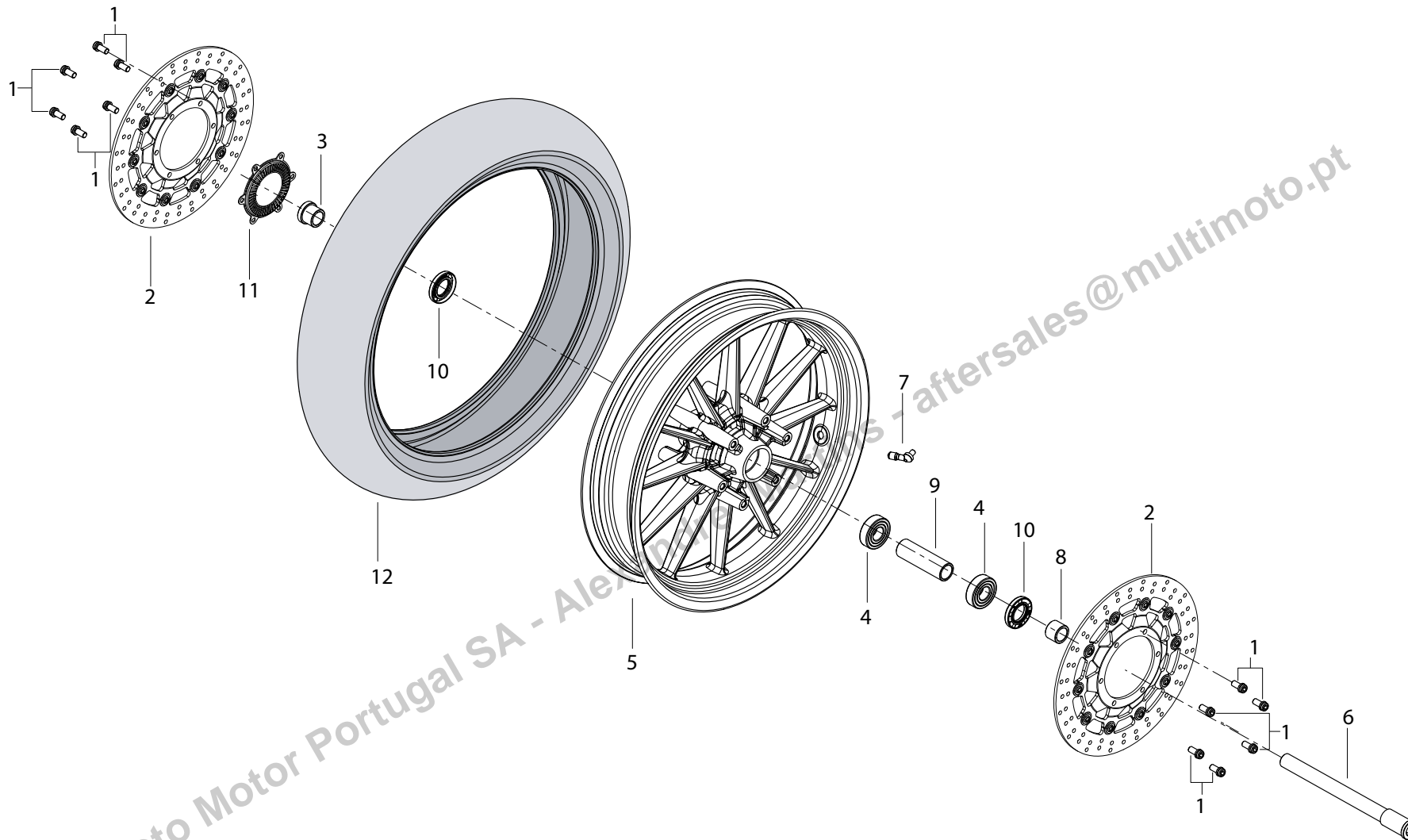

POS. NO. N. INDEX POS.	N. CODICE CODE NO. Nr. CODE ATRIKEL Nr. CODICO Nr.	DESCRIZIONE	DESCRIPTION	DESIGNATION	BEZEICHNUNG	DENOMINACION	NOTE NOTES NOTES MARKE NOTAS	Q.TA' CONF. Q.TY PACK. Q.TE EMB. M.GE PAK. C.AD PAQ.	
1	B02810802062	VITE (M8X1.25X20)	SCREW (M8X1.25X20)	VIS (M8X1.25X20)	SHARAUBE (M8X1.25X20)	TORNILLO (M8X1.25X20)		5	
2	45030P160000	DISCO FRENO ANTERIORE	FRONT BRAKE DISC	DISQUE FREIN AVANT	VORDERBREMSSCHEIBE	DISCO FRENO DELANTERO		1	
3	44005P160000	DISTANZIALE SINISTRO	L.H. SPACER	ENTRETOISE GAUCHE	LINKES DISTANZSTÜCK	DISTANCIADOR IZQ.		1	
4	B12016020400	CUSCINETTO	BEARING	ROULEMENT	LAGER	COJINETE		1	
5	R320471003000	CERCHIO RUOTA ANTERIORE (GRIGIO)	FRONT WHEEL RIM (GREY)	JANTE ROUE AVANT (GRIS)	VORDERRADFELGE (GRAU)	LLANTA RUEDA DELANTERA (GRIS)		1	
6	44004P160100	PERNO RUOTA ANTERIORE	FRONT WHEEL SPINDLE	PIVOT ROUE AVANT	VORDES REIFEN	PERNO RUEDA DELANTERA		1	
7	R020072108000	VALVOLA	VALVE	SOUPAPE	VENTIL	VÁLVULA		1	
8	R320452246000	DISTANZIALE	SPACER	ENTRETOISE	DISTANZSTÜCK	DISTANCIAL		1	
9	44006P100100	DISTANZIALE INTERNO	INNER SPACER	ENTRETOISE INTERNE	INNERES DISTANZSTÜCK	DISTANCIADOR INTERIOR		1	
10	60200J000001	PARAOILIO	OIL SEAL	BAGUE D'ETANCHEITE	WELLENDICHTRING	RETEN DE ACEITE		1	
11	45702P160000	RUOTA FONICA ABS	WHEEL SPEED FASTENING ABS	D' ATTACHE DE FIXATION DE ROUE PHONIQUE ABS	RAD-GESCHWINDIGKEIT BEFESTIGUNGSINSTALLATIONS ABS	FIJACIÓN DE LA RUEDA FÓNICA ABS		1	
12	B140507D1700	PNEUMATICO ANTERIORE (120/70-17)	FRONT TIRE (120/70-17)	PNEU AVANT (120/70-17)	VORDERERGUMMIREIFEN (120/70-17)	NEUMÁTICO DELANTERO (120/70-17)		1	



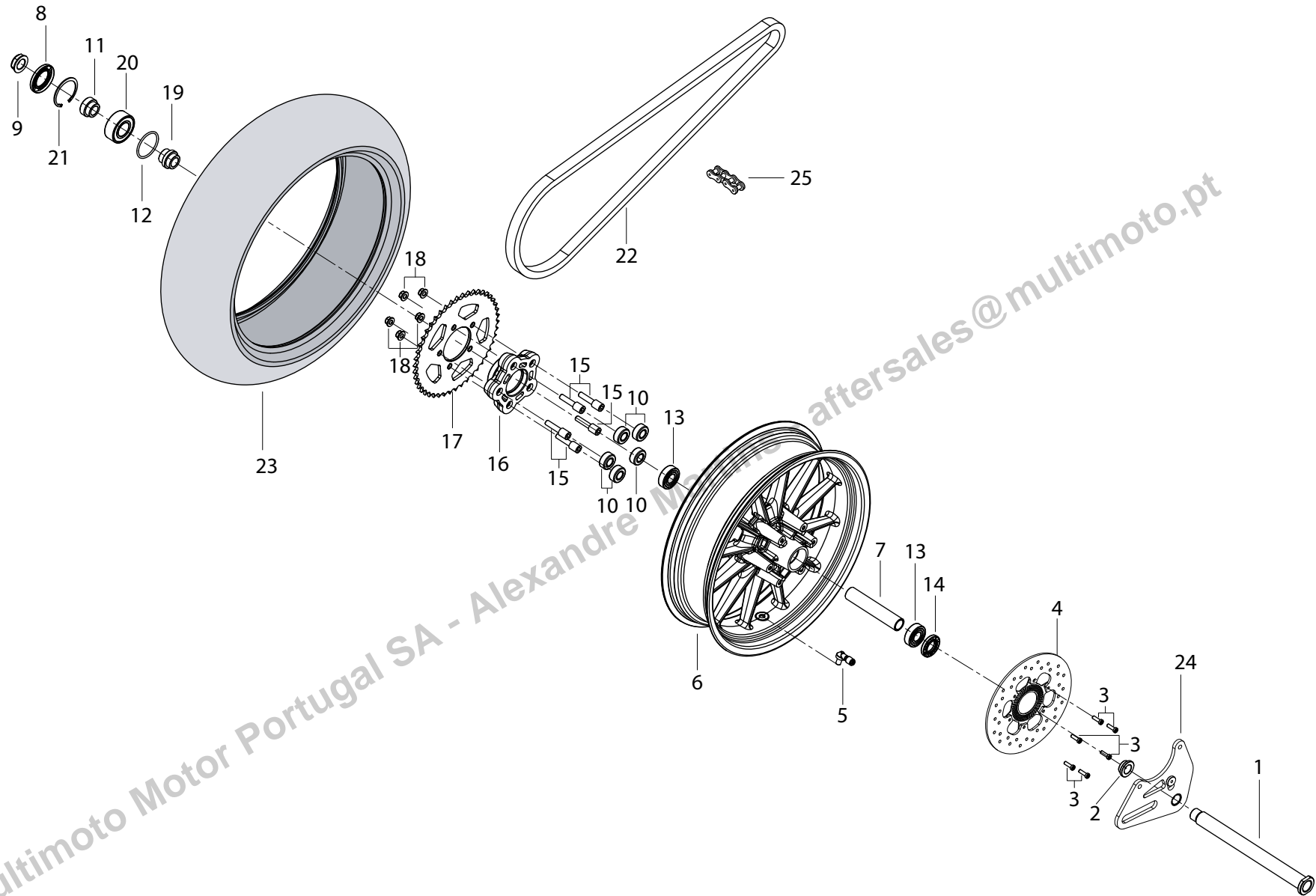

SSMT

POS. NO. N. INDEX POS.	N. CODICE CODE NO. Nr. CODE ATRIBEL NR. CODICO Nr.	DESCRIZIONE	DESCRIPTION	DESIGNATION	BEZEICHNUNG	DENOMINACION	NOTE NOTES NOTES MARKE NOTAS	Q.TA' CONF. Q.TY PACK. Q.TE EMB. M.GE PAK. C.AD PAQ.	
1	54004P100100	PERNO RUOTA POSTERIORE	REAR WHEEL SPINDLE	PIVOT ROUE ARRIÈRE	ZAPFEN REIFEN HINTERER	PERNO RUEDA TRASERA		1	
2	54005P100100	BOCCOLA	BUSH	DOUILLE	BUCHSE	CASQUILLO		1	
3	R90350671C	VITE (M6X20)	SCREW (M6X20)	VIS (M6X20)	SHARAUBE (M6X20)	TORNILLO (M6X20)		1	
4	55030P160000	DISCO FRENO POSTERIORE	REAR BRAKE DISC	DISQUE FREIN ARRIERE	HINTERE BREMSSCHEIBE	DISCO FRENO TRASERO		1	
5	R020072108000	VALVOLA	VALVE	SOUPAPE	VENTIL	VÁLVULA		1	
6	54100P10HT0Z	CERCHIO RUOTA POSTERIORE (NERO)	REAR WHEEL RIM (BLACK)	JANTE ROUE ARRIÈRE (NOIR)	HINTERRADFELGE (SCHWARZ)	LLANTA RUEDA TRASERA (NEGRO)		1	
7	R320452104000	DISTANZIALE INTERNO	INNER SPACER	ENTRETOISE INTERNE	INNERES DISTANZSTÜCK	DISTANCIADOR INTERIOR		1	
8	60200P100000	PARAPOLVERE	SEAL_DUST	PARE POUSSIERE	STAUBDECKEL	GUARDAPOLVO		1	
9	08051P100100	DADO	NUT	ECROU	MUTTER	TUERCA		1	
10	546225010000	GOMMA PARASTRAPPI	SPRING DRIVE RUBBER	CAOUTCHOUC FLECTEUR	STOESSCHUTZGUMMI	GOMA JUNTA AMORTIGUADORA		1	
11	R320452077000	DISTANZIALE	SPACER	ENTRETOISE	DISTANZSTÜCK	DISTANCIAL		1	
12	B190105300C0	GUARNIZIONE O-RING	O-RING	JOINT D'ÉTANCHÉITÉ	DICHTUNG O-RING	JUNTA OR		1	
13	B12016020400	CUSCINETTO	BEARING	ROULEMENT	LAGER	COJINETE		1	
14	60200J000001	PARAOLIO	OIL SEAL	BAGUE D'ETANCHEITE	WELLENDICHTRING	RETEN DE ACEITE		1	
15	60015P250010	VITE (M10X41)	SCREW (M10X41)	VIS (M10X41)	SCHRAUBE (M10X41)	TORNILLO (M10X41)		1	
16	60001P100000	FLANGIA PORTA CORONA	REAR SPROCKET FLANGE	BRIDE PORTE-COURONNE	KRANZHALTEFLANSCH	BRIDA PORTA-CORONA		1	
17	60002P160000	CORONA (Z42)	RING GEAR (Z42)	COURONNE (Z42)	KRANZ (Z42)	CORONA (Z42)		1	
18	R91350091B	DADO (M10)	NUT (M10)	ECROU (M10)	MUTTER (M10)	TUERCA (M10)		1	
19	54016P100100	DISTANZIALE	SPACER	ENTRETOISE	DISTANZSTÜCK	DISTANCIAL		1	
20	R180172114000	CUSCINETTO	BEARING	ROULEMENT	LAGER	COJINETE		1	
21	R92652620D	ANELLO ELASTICO	SNAP RING	BAGUE ÉLASTIQUE	SPRENGRING	SEAGER		1	
22	60310P160002	CATENA TRASMISSIONE	TRANSMISSION CHAIN	CHAÎNE DE TRANSMISSION	GETRIEBE-KETTE	CADENA DE LA TRANSMISIÓN		1	
23	B140111C1780	PNEUMATICO POSTERIORE 160/60-R17	REAR TIRE 160/60-R17	PNEU ARRIÈRE 160/60-R17	REIFEN HINTEREN 160/60-R17	NEUMÁTICO TRASERO 160/60-R17		1	
24	55610P160000	PIASTRA PORTA PINZA	CALIPER HOLDER PLATE	PLAQUE PORTE-PINCE	BREMSSZANGENPLATTE	LÁMINA PORTA-PINZA		1	
25	R180227030000	MAGLIA GIUNZIONE CATENA (REGINA ARGENTO)	CHAIN SECTOR	SECTEUR À CHAÎNE	KETTENSEKTOR	SECTOR DE CADENA		1	

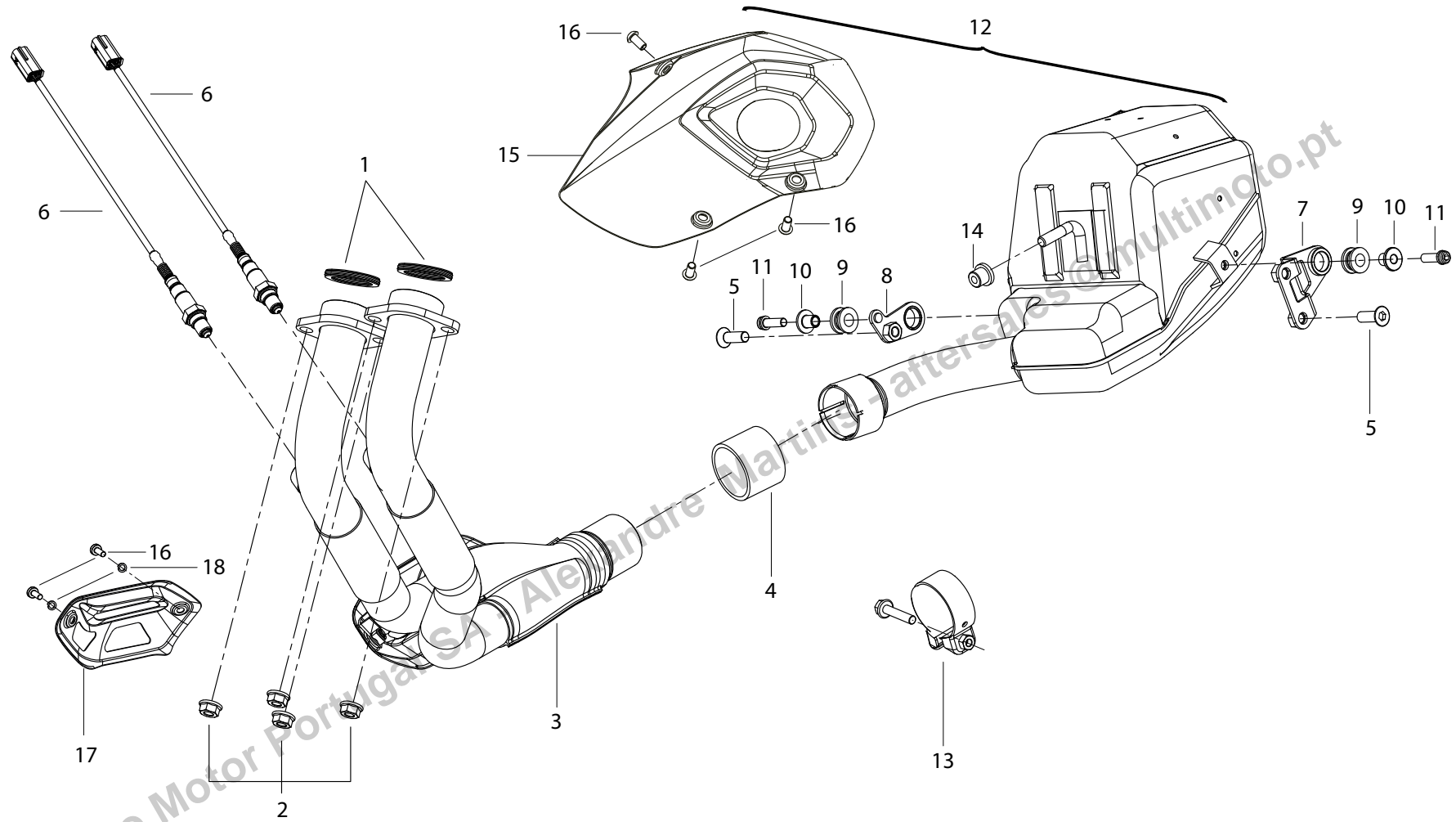

POS. NO. N. INDEX POS.	N. CODICE CODE NO. Nr. CODE ATRIBEL Nr. CODICO Nr.	DESCRIZIONE	DESCRIPTION	DESIGNATION	BEZEICHNUNG	DENOMINACION	NOTE NOTES NOTES MARKE NOTAS	Q.TA' CONF. Q.TY PACK. Q.TE EMB. M.GE PAK. C.AD PAQ.	
1	47800P250000	GUARNIZIONE SCARICO	EXHAUST GASKET	GARNITURE DE DÉCHARGE	AUSPUFFDICHTUNG	JUNTA ESCAPE		1	
2	R320052054000	DADO (M8)	NUT (M8)	ECROU (M8)	MUTTER (M8)	TUERCA (M8)		1	
3	47500P160201	COLLETTORE DI SCARICO	EXHAUST MANIFOLD	COLLECTEUR D'ÉCHAPPEMENT	AUSPUFFKRÜMMER	COLECTOR DE ESCAPE		1	
4	47035P250000	GUARNIZIONE GRAFITE	GASKET (GRAPHITE)	GARNITURE (GRAPHITE)	DICHTUNG (GRAPHITE)	JUNTA (GRAPHITE)		1	
5	B0217100306H	VITE (M10X30)	SCREW (M10X30)	VIS (M10X30)	SCHRAUBE (M10X30)	TORNILLO (M10X30)		1	
6	319026280000	SONDA LAMBDA	LAMBDA SENSOR	LAMBDA SENSOR	LAMBDA SENSOR	LAMBDA SENSOR		1	
7	47610P160001	FLANGIA SINISTRA	L. H. FLANGE	BRIDE GAUCHE	LINKES FLANSCH	BRIDA IZQUIERDA	until frame n. ZBNP16008HB770779	1	
8	47620P160002	FLANGIA DESTRA	R. H. FLANGE	BRIDE DROITE	RECHT FLANSCH	BRIDA DERECHA	from frame n. ZBNP16008HB770780	1	
9	65617H010010	GOMMINO	RUBBER PAD	JOINT EN CAOUTCHOUC	GUMMISTÜCK	JUNTA DE GOMA		1	
10	65613P260000	BOCCOLA	BUSH	DOUILLE	BUCHSE	CASQUILLO		1	
11	R90751451B	VITE (TCEI M8X25)	SCREW (TCEI M8X25)	VIS (TCEI M8X25)	SHARAUBE (TCEI M8X25)	TORNILLO (TCEI M8X25)		1	
12	47200P160200	SILENZIATORE	SILENCER	SILENCIEUX	SCHALLDÄMPFER	SILENCIADOR		1	
13	48830P290000	FASCETTA A VITE	SCREW HOSE CLAMP	COLLIER À VISSER	SCHRAUBENSCHELLE	ABRAZADERA A TORNILLO		1	
14	47026P160000	GOMMINO	RUBBER PAD	JOINT EN CAOUTCHOUC	GUMMISTÜCK	JUNTA DE GOMA		1	
15	47761P160000	PROTEZIONE MARMITTA	MUFFLER PROTECTION	PROTECTION SILENCIEUX	MUFFLER SCHUTZ	PROTECCIÓN ESCAPE		1	
16	B0218060106A	VITE (M6X10)	SCREW (M6X10)	VIS (M6X10)	SHARAUBE (M6X10)	TORNILLO (M6X10)		1	
17	47761P160001	PROTEZIONE MARMITTA	MUFFLER PROTECTION	PROTECTION SILENCIEUX	MUFFLER SCHUTZ	PROTECCIÓN ESCAPE		1	
18	B0700000060A	RONDELLA	WASHER	RONDELLE	UNTERLEGSCHIEBE	ARANDELA		1	

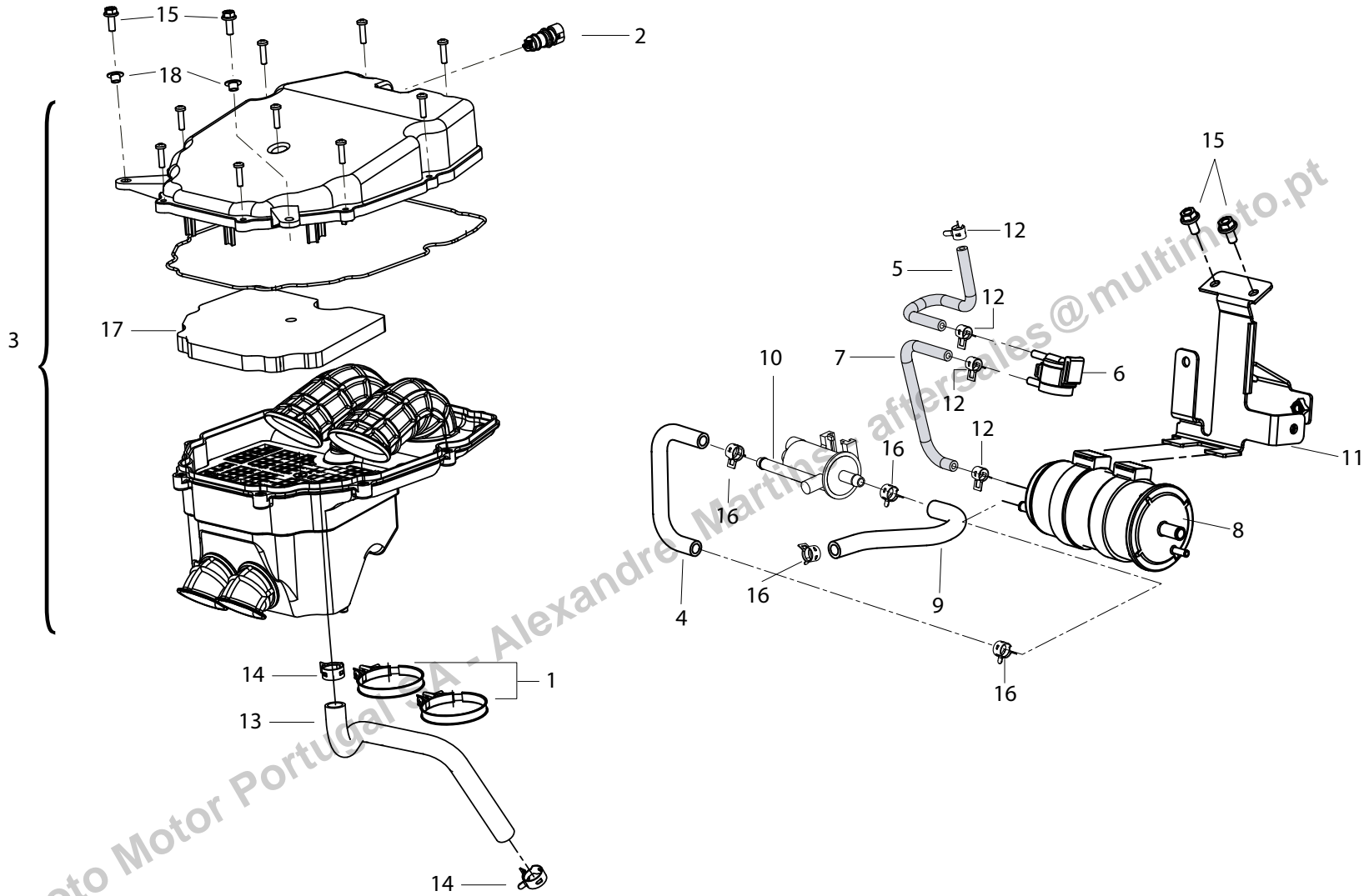

POS. NO. N. INDEX POS.	N. CODICE CODE NO. Nr. CODE ATRÍKEL Nr. CODICO Nr.	DESCRIZIONE	DESCRIPTION	DESIGNATION	BEZEICHNUNG	DENOMINACION	NOTE NOTES NOTES MARKE NOTAS	Q.TA' CONF. Q.TY PACK. Q.TE EMB. M.GE PAK. C.AD PAQ.	
1	R32045220000	FASCETTA A VITE	SCREW HOSE CLAMP	COLLIER À VISSER	SCHRAUBENSHELLE	ABRAZADERA A TORNILLO		1	
2	310015040000	SENSORE TEMPERATURA ARIA	AIR TEMPERATURE SENSOR	CAPTEUR TEMPÉRATURE AIR	LUFTEMPERATURSENSOR	SENSOR TEMPERATURA AIRE		1	
3	49100P160000	SCATOLA FILTRO ARIA COMPLETA	COMPLETE AIR FILTER BOX	BOÎTE FILTRE À AIR COMPLET	LUFTFILTERKASTEN KOMPLETT	CAJA FILTRO AIRE COMPLETO		1	
4	49922P160000	TUBO	TUBE	TUBE	ROHR	TUBO		1	
5	B16010422901	TUBO	TUBE	TUBE	ROHR	TUBO		1	
6	50260T730003	VALVOLA DI NON RITORNO	ONE-WAY VALVE	VALVE À SENS UNIQUE	EINWEGVENTIL	VÁLVULA DE UNA VÍA		1	
7	B16010425951	TUBO	TUBE	TUBE	ROHR	TUBO		1	
8	R320490125000	FILTRO CANISTER	FILTER CANISTER	FILTRE CANISTER	FILTER CANISTER	FILTRO CANISTER		1	
9	49923P160000	TUBO	TUBE	TUBE	ROHR	TUBO		1	
10	49710N070000	VALVOLA	VALVE	SOUPAPE	VENTIL	VALVULA		1	
11	57050P160000	PIASTRA	PLATE	PLAQUE	PLATTE	SOPORTE		1	
12	50306T450010	FASCETTA A MOLLA	SPRING HOSE CLAMP	COLLIER À RESSORT	FEDERSHELLE	ABRAZADERA A MUELLE		10	
13	R320460105000	MANICOTTO	HOSE	MANCHON	MUFFE	MANGUETA		1	
14	R020086166000	MOLLETTA PASSATUBO	HOSE GUIDE SPRING	RESSORT PASSE-TUBE	FEDER LEITUNGSFÜHRUNG	MUELLE PASATUBO		10	
15	B0109060166H	VITE (M6X16)	SCREW (M6X16)	VIS (M6X16)	SHARAUBE (M6X16)	TORNILLO (M6X16)		1	
16	50307J140002	FASCETTA A MOLLA	SPRING HOSE CLAMP	COLLIER À RESSORT	FEDERSHELLE	ABRAZADERA A MUELLE		10	
17	49202P160000	FILTRO ARIA	AIR FILTER	FILTRE À AIR	LUFTFILTER	FILTRO AIRE		1	
18	R90750351B	BOCCOLA	BUSH	DOUVILLE	BUCHSE	CASQUILLO		1	

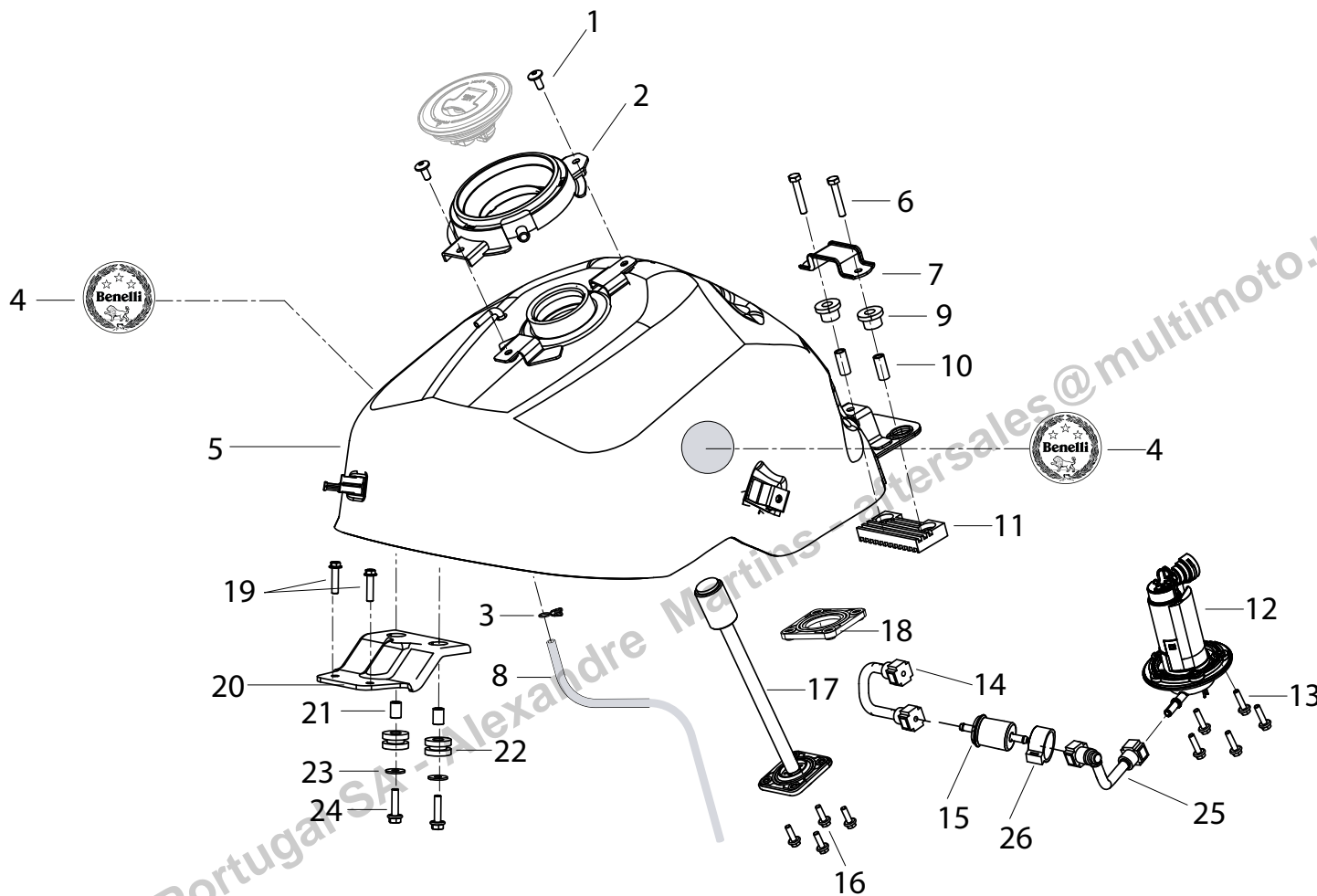

POS. NO. N. INDEX POS.	N. CODICE CODE NO. Nr. CODE ATRIBEL Nr. CODICO Nr.	DESCRIZIONE	DESCRIPTION	DESIGNATION	BEZEICHNUNG	DENOMINACION	NOTE NOTES NOTES MARKE NOTAS	Q.TA' CONF. Q.TY PACK. Q.TE EMB. M.GE PAK. C.AD PAQ.	
1	R90752031B	VITE (M6X14)	SCREW (M6X14)	VIS (M6X14)	SHARAUBE (M6X14)	TORNILLO (M6X14)		5	
2	65679V02000	CHIUSURA CARENA CENTRALE	CENTRAL CLOSING FAIRING	FERMETURE CARÈNE CENTRAL	VERSCHLUSS VERKLEIDUNG MITTLERER	CIERRE CARENADO CENTRAL		1	
3	R700052132000	MOLLA	SPRING	RESSORT	FEDER	MUELLE		5	
4	05533P16WS04	ADESIVO LOGO (BENELLI)	STICKER LOGO (BENELLI)	DÉCALCOMANIE LOGO (BENELLI)	AUFKLEBER LOGO (BENELLI)	ADHESIVO LOGO (BENELLI)		1	
4	05533P16JS04	ADESIVO LOGO (BENELLI)	STICKER LOGO (BENELLI)	DÉCALCOMANIE LOGO (BENELLI)	AUFKLEBER LOGO (BENELLI)	ADHESIVO LOGO (BENELLI)		1	
5	50100P160000	SERBATOIO BENZINA	FUEL TANK	RÉSERVOIR CARBURANT	KRAFTSTOFFTANK	DEPÓSITO GASOLINA		1	
6	R90750541B	VITE (M6X35)	SCREW (M6X35)	VIS (M6X35)	SHARAUBE (M6X35)	TORNILLO (M6X35)		1	
7	R320457046000	PIASTRA	PLATE	PLAQUE	PLATTE	SOPORTE		1	
8	B160107C6001	TUBO	TUBE	TUBE	ROHR	TUBO		1	
9	50222J000001	BUSSOLA	BUSH	DOUILLE	BUCHSE	CASQUILLO		1	
10	50221J000001	BOCCOLA	BUSH	DOUILLE	BUCHSE	CASQUILLO		1	
11	R320457047000	GOMMINO ANTIVIBRANTE	VIBRATION DAMPER PAD	JOINT EN CAOUTCHOUC ANTI-VIBRATION	SCHWINGUNGSDÄMPFERGUMMI	JUNTA DE GOMA ANTI-VIBRACIÓN		1	
12	50400P160000	POMPA BENZINA	FUEL PUMP	POMPE CARBURANT	BENZINPUMPE	BOMBA GASOLINA		1	
13	B01090502065	VITE (M5X20)	SCREW (M5X20)	VIS (M5X20)	SCHRAUBE (M5X20)	TORNILLO (M5X20)		1	
14	50090P160000	TUBO BENZINA	FUEL PIPE	TUYAU ESSENCE	BENZINSCHLAUCH	TUBO GASOLINA		1	
15	50340N070000	FILTRO BENZINA	FUEL FILTER	FILTRE À ESSENCE	BENZINFILTER	FILTRO GASOLINA		1	
16	B0109050166H	VITE (M5X16)	SCREW (M5X16)	VIS (M5X16)	SHARAUBE (M5X16)	TORNILLO (M5X16)		1	
17	50800P160000	SONDA LIVELLO CARBURANTE	FUEL LEVEL SENSOR	SONDE DE NIVEAU CARBURANT	KRAFTSTOFFPEGELSONDE	SONDA NIVEL GASOLINA		1	
18	50808P250010	GUARNIZIONE SONDA LIVELLO CARBURANTE	GASKET FUEL LEVEL SENSOR	GARNITURE SONDE DE NIVEAU CARBURANT	DICHTUNG KRAFTSTOFFPEGELSONDE	JUNTA SONDA NIVEL COMBUSTIBLE		1	
19	B0109060166H	VITE (M6X16)	SCREW (M6X16)	VIS (M6X16)	SHARAUBE (M6X16)	TORNILLO (M6X16)		1	
20	50027P160000	PIASTRA	PLATE	PLAQUE	PLATTE	SOPORTE		1	
21	R320052069000	BOCCOLA	BUSH	DOUILLE	BUCHSE	CASQUILLO		1	
22	50005P250000	GOMMINO	RUBBER PAD	JOINT EN CAOUTCHOUC	GUMMISTÜCK	JUNTA DE GOMA		1	
23	R320052072000	RONDELLA	WASHER	RONDELLE	UNTERLEGSCHIEBE	ARANDELA		1	
24	160106030130	VITE (M6X30)	SCREW (M6X30)	VIS (M6X30)	SHARAUBE (M6X30)	TORNILLO (M6X30)		1	

 **SERBATOIO**

 **FUEL TANK**

 **RÉSERVOIR
CARBURANT**

 **KRAFTSTOFFTANK**

 **DEPÓSITO GASOLINA**

TAVOLA
DRAWING
TABLE
BILD
TABLA

POS. NO. N. INDEX POS.	N. CODICE CODE NO. Nr. CODE ATRİKEL Nr. CODICO Nr.	DESCRIZIONE	DESCRIPTION	DESIGNATION	BEZEICHNUNG	DENOMINACION	NOTE NOTES NOTES MARKE NOTAS	Q.TA' CONF. Q.TY PACK. Q.TE EMB. M.GE PAK. C.AD PAQ.	
25	50360P160000	TUBO BENZINA	FUEL PIPE	TUYAU ESSENCE	BENZINSCHLAUCH	TUBO GASOLINA		1	
26	50391N070010	SUPPORTO FILTRO	HOLDER FILTER	SUPPORT FILTRE	HALTERUNG FILTER	SOPORTE FILTRO		1	



Multimoto Motor Portugal SA - Alexandre Martins - aftersales@multimoto.pt

 **CARENATURE ANTERIORI**

 **FRONT FAIRINGS**

 **CARENAGES AVANT**

 **SCHALE FRONTSEITE**

 **BASTIDOR DELANTERO**

TAVOLA
DRAWING
TABLE
BILD
TABLA

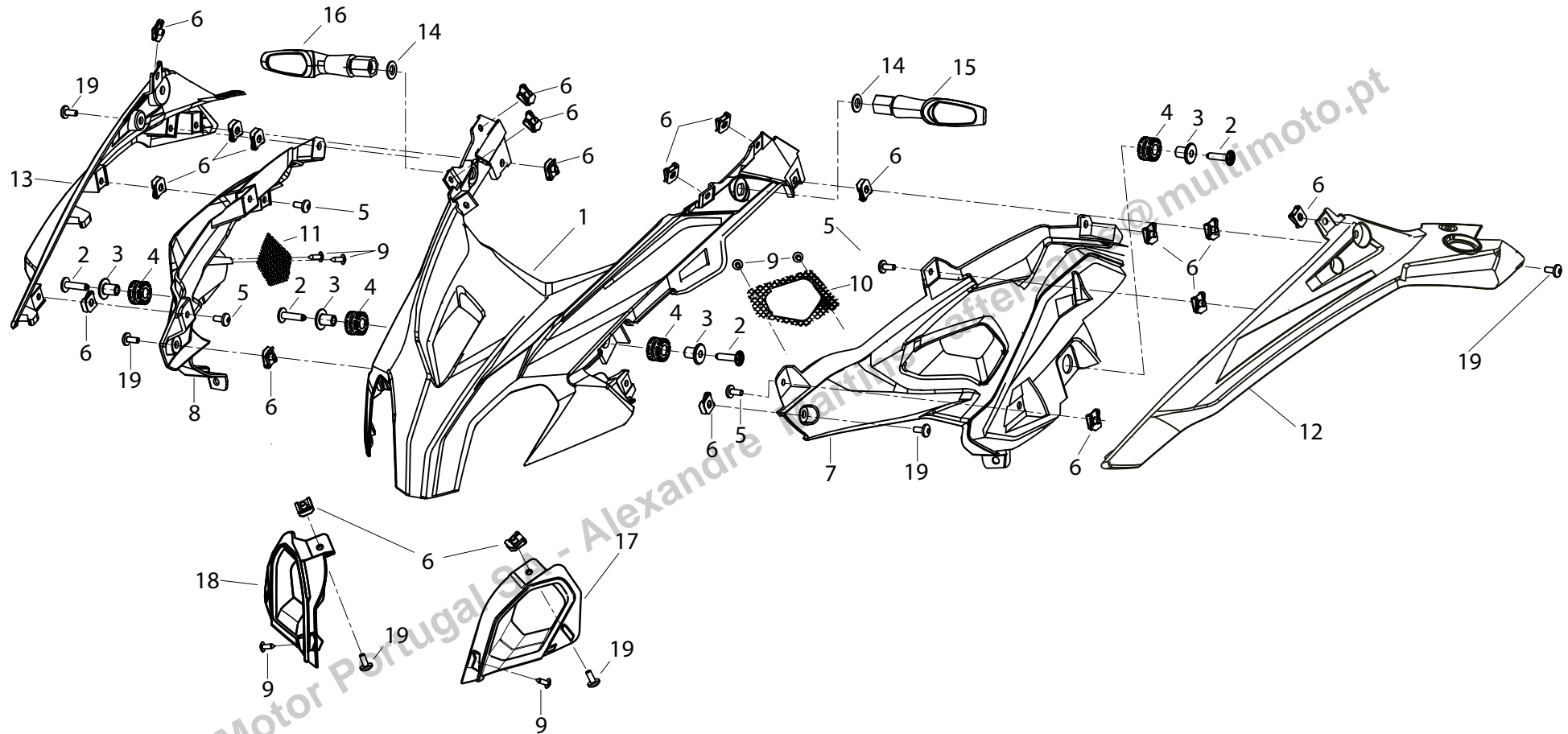

POS. NO. N. INDEX POS.	N. CODICE CODE NO. Nr. CODE ATRIKEL Nr. CODICO Nr.	DESCRIZIONE	DESCRIPTION	DESIGNATION	BEZEICHNUNG	DENOMINACION	NOTE NOTES NOTES MARKE NOTAS	Q.TA' CONF. Q.TY PACK. Q.TE EMB. M.GE PAK. C.AD PAQ.	
1	65301P16BA00	CARENA ANTERIORE	FRONT FAIRING	CARÉNAGE AVANT	VORDERSHALE	CARENADO DELANTERO		1	
2	R320452063000	VITE (M6X25)	SCREW (M6X25)	VIS (M6X25)	SHARAUBE (M6X25)	TORNILLO (M6X25)		1	
3	140035040010	BOCCOLA SUPERIORE	UPPER BUSH	DOUILLE SUPÉRIEURE	OBERER BUCHSE	CASQUILLO SUPERIOR		1	
4	R180479181000	GOMMINO	RUBBER PAD	JOINT EN CAOUTCHOUC	GUMMISTÜCK	JUNTA DE GOMA		1	
5	08011P160000	VITE (M5X12)	SCREW (M5X12)	VIS (M5X12)	SCHRAUBE (M5X12)	TORNILLO (M5X12)		1	
6	65624P160000	CLIP FISSAGGIO RAPIDO (M5)	QUIK FASTENING (M5)	FIXATION RAPIDE (M5)	SCHNELLEBESFESTIGUNG (M5)	FIJACIÓN RÁPIDA (M5)		1	
7	65316P160000	CONVOGLIATORE ARIA SINISTRO	AIR MANIFOLD L.H.	CONVOYEUR D'AIR GAUCHE	LUFTFÖRDERER LINK	ENCANALADOR AIRE IZQUIERDO		1	
8	65317P160000	CONVOGLIATORE ARIA DESTRO	R.H. AIR MANIFOLD	CONVOYEUR D'AIR DROIT	LUFTFÖRDERER RECHT	ENCANALADOR AIRE DERECHO		1	
9	B05074201305	VITE (ST4.2X13)	SCREW (ST4.2X13)	VIS (ST4.2X13)	SHARAUBE (ST4.2X13)	TORNILLO (ST4.2X13)		10	
10	65318P160000	RETINA SINISTRA	L.H. NET	GRILLE GAUCHE	LINKES NETZ	RED IZQUIERDA		1	
11	65319P160000	RETINA DESTRA	R.H. NET	GRILLE DROITE	NETZ RECHTS	RED DERECHA		1	
12	65303P16WS00	FIANCHETTO SINISTRO (BIANCO)	L.H. BODY PANEL (WHITE)	PANNEAU LATÉRAL GAUCHE (BLANC)	LINKES SEITENABDECKUNG (WEISS)	PANEL LATERAL IZQUIERDO (BLANCO)	WHITE	1	
12	65303P16JS00	FIANCHETTO SINISTRO (GRIGIO)	L.H. BODY PANEL (GREY)	PANNEAU LATÉRAL GAUCHE (GRIS)	LINK SEITENABDECKUNG (GRAU)	PANEL LATERAL IZQUIERDO. (GRIS)	RED	1	
12	65303P16FH00	FIANCHETTO SINISTRO (ROSSO FH)	L.H. BODY PANEL (RED)	PANNEAU LATÉRAL GAUCHE (ROUGE)	LINKES SEITENABDECKUNG (ROT)	PANEL LATERAL IZQUIERDO (ROJO)	GREY	1	
12	65303P16KD00	FIANCHETTO SINISTRO (BLUE KD)	L.H. BODY PANEL (BLUE KD)	PANNEAU LATÉRAL GAUCHE (BLEU KD)	LINKES SEITENABDECKUNG (BLAU KD)	PANEL LATERAL IZQUIERDO (AZUL KD)	WHITE	1	
13	65309P16WS00	FIANCHETTO DESTRO (BIANCO WS)	R.H. BODY PANEL (WHITE WS)	PANNEAU LATÉRAL DROITE (BLANC WS)	RECHTES SEITENABDECKUNG (WEIß WS)	PANEL LATERAL DERECHA (BLANCO WS)	RED	1	
13	65309P16JS00	FIANCHETTO DESTRO (GRIGIO)	R.H. BODY PANEL (GREY)	PANNEAU LATÉRAL DROITE (GRIS)	RECHT SEITENABDECKUNG (GRAU)	PANEL LATERAL DERECHO (GRIS)	GREY	1	
13	65309P16FH00	FIANCHETTO DESTRO (ROSSO FH)	R.H. BODY PANEL (RED FH)	PANNEAU LATÉRAL DROITE (ROUGE FH)	RECHT SEITENABDECKUNG (ROT FH)	PANEL LATERAL DERECHO (ROJO FH)		1	
13	65309P16KD00	FIANCHETTO DESTRO (BLUE KD)	R.H. BODY PANEL (BLUE KD)	PANNEAU LATÉRAL DROITE (BLEU KD)	RECHT SEITENABDECKUNG (BLAU KD)	PANEL LATERAL DERECHO (AZUL KD)		1	
14	08023P250000	RONDELLA	WASHER	RONDELLE	UNTERLEGSSCHEIBE	ARANDELA		1	
15	81100V020000	INDICATORE DI DIREZIONE COMPLETO (ANTERIORE SINISTRO)	COMPLETE TURN INDICATOR (FRONT L.H.)	CLIGNOTANT COMPLÈTE (AVANT GAUCHE)	FAHRRICHTUNGSANZEIGE KOMPLETT (VORDERES LINK)	INDICADOR DE DIRECCIÓN COMPLETA (DELANTERO IZQUIERDO)		1	
16	81300V020000	INDICATORE DI DIREZIONE COMPLETO (ANTERIORE DESTRO)	COMPLETE TURN INDICATOR (FRONT R.H.)	CLIGNOTANT COMPLÈTE (AVANT ARRIERE)	FAHRRICHTUNGSANZEIGE KOMPLETT (VORDERES RECHT)	INDICADOR DE DIRECCIÓN COMPLETA (DELANTERO DERECHO)		1	
17	65305P16BA00	PRESA ARIA SINISTRA	L.H. AIR INTAKE	PRISE D'AIR GAUCHE	LUFTEINLASS LINKS	TOMA DE AIRE IZQUERDA		1	
18	65306P16BA00	PRESA ARIA DESTRA	R.H. AIR INTAKE	PRISE D'AIR DROITE	LUFTEINLASS RECHTS	TOMA DE AIRE DERECHA		1	

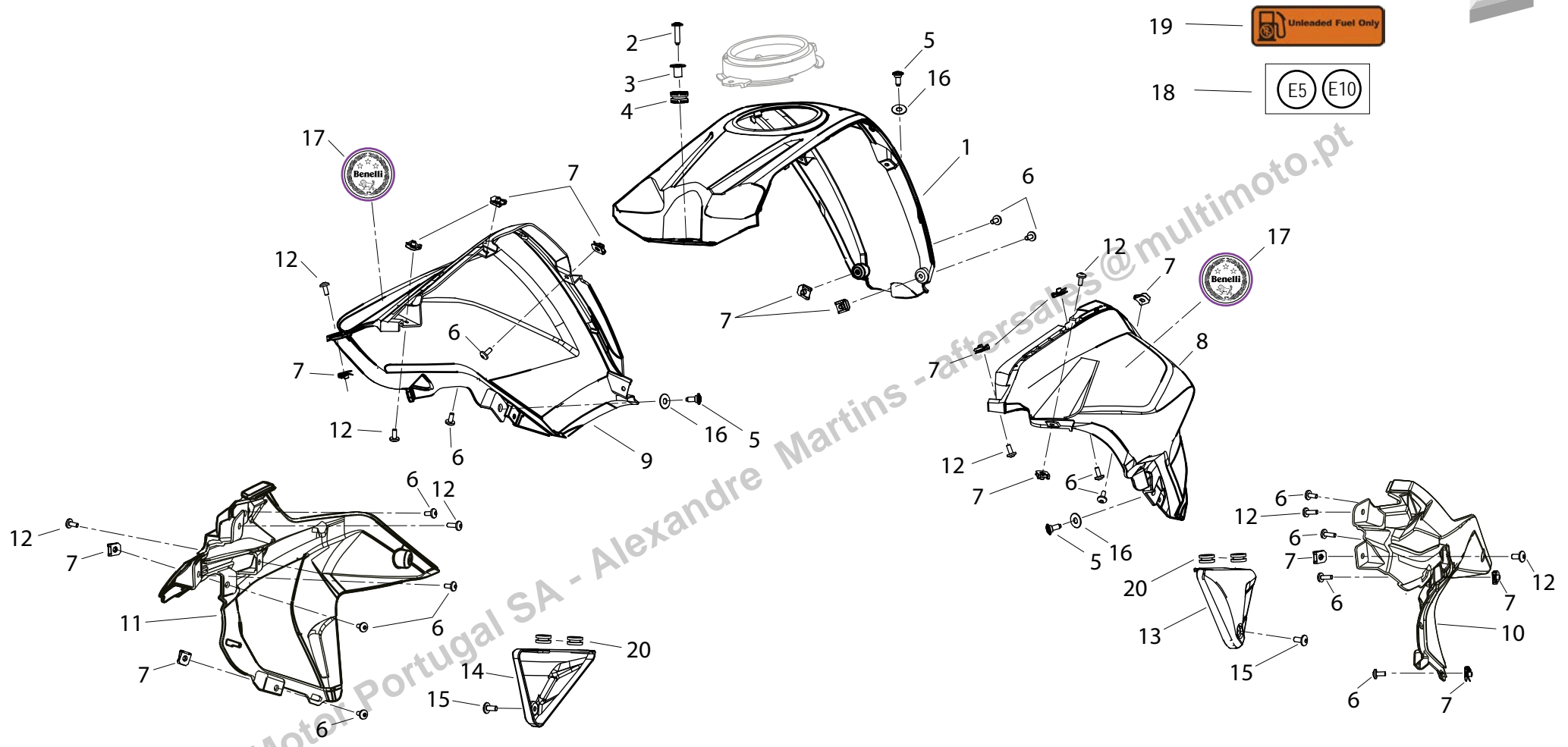

POS. NO. N. INDEX POS.	N. CODICE CODE NO. Nr. CODE ATRIKEL Nr. CODICO Nr.	DESCRIZIONE	DESCRIPTION	DESIGNATION	BEZEICHNUNG	DENOMINACION	NOTE NOTES NOTES MARKE NOTAS	Q.TA' CONF. Q.TY PACK. Q.TE EMB. M.GE PAK. C.AD PAQ.	
1	65672P16BA00	CALOTTA CENTRALE SERBATOIO BENZINA	CENTRAL FUEL TANK CAP	CALOTTE CENTRAL RÉSERVOIR CARBURANT	KAPPE ZENTRAL KRAFTSTOFFTANK	CASQUETE CENTRAL DEPÓSITO GASOLINA		1	
2	R320452063000	VITE (M6X25)	SCREW (M6X25)	VIS (M6X25)	SHARAUBE (M6X25)	TORNILLO (M6X25)		1	
3	140035040010	BOCCOLA SUPERIORE	UPPER BUSH	DOUILLE SUPÉRIEURE	OBERER BUCHSE	CASQUILLO SUPERIOR		1	
4	R180479181000	GOMMINO	RUBBER PAD	JOINT EN CAOUTCHOUC	GUMMISTÜCK	JUNTA DE GOMA		1	
5	R90752268E	VITE (M6X15.2)	SCREW (M6X15.2)	VIS (M6X15.2)	SHARAUBE (M6X15.2)	TORNILLO (M6X15.2)		5	
6	08011P160000	VITE (M5X12)	SCREW (M5X12)	VIS (M5X12)	SCHRAUBE (M5X12)	TORNILLO (M5X12)		1	
7	65624P160000	CLIP FISSAGGIO RAPIDO (M5)	QUIK FASTENING (M5)	FIXATION RAPIDE (M5)	SCHNELLEBEFESTIGUNG (M5)	FIJACIÓN RÁPIDA (M5)		1	
8	65673P16WS00	CALOTTA SERBATOIO BENZINA SINISTRA (BIANCO WS)	L.H. FUEL TANK CAP (WHITE WS)	CALOTTE RÉSERVOIR CARBURANT GAUCHE (BLANC)	KAPPE KRAFTSTOFFTANK LINKES (WEIß)	CASQUETE DEPÓSITO GASOLINA IZQ. (BLANCO)		1	
8	65673P16JS00	CALOTTA SERBATOIO BENZINA SINISTRA (GRIGIO)	L.H. FUEL TANK CAP (GREY)	CALOTTE RÉSERVOIR CARBURANT GAUCHE (GRIS)	KAPPE KRAFTSTOFFTANK LINKSES (GRAU)	CASQUETE DEPÓSITO GASOLINA IZQ. (GRIS)		1	
8	65673P16FH00	CALOTTA SERBATOIO BENZINA SINISTRA (ROSSO FH)	L.H. FUEL TANK CAP (RED FH)	CALOTTE RÉSERVOIR CARBURANT GAUCHE (ROUGE FH)	KAPPE KRAFTSTOFFTANK LINKES (ROT FH)	CASQUETE DEPÓSITO GASOLINA IZQ. (ROJO FH)		1	
8	65673P16KD00	CALOTTA SERBATOIO BENZINA SINISTRA (BLU KD)	L.H. FUEL TANK CAP (BLUE KD)	CALOTTE RÉSERVOIR CARBURANT GAUCHE (BLEU KD)	KAPPE KRAFTSTOFFTANK LINKES (BLAU KD)	CASQUETE DEPÓSITO GASOLINA IZQ. (AZUL KD)		1	
8	65673P16016Z	CALOTTA SERB BENZ SINISTRA (BIANCO WS) CON ADESIVI	L.H. FUEL TANK CAP (WHITE WS) WITH STICKERS	CALOTTE RÉSERVOIR CARB GAUCHE (BLANC) AVEC DECALCOMANIE	KAPPE KRAFTSTOFFTANK LINKES (WEIß) MIT AUFKLEBER	CASQUETE DEPÓSITO GASOLINA IZQ. (BLANCO) CON ADHESIVO		1	
8	65673P16017Z	CALOTTA SERB BENZINA SINISTRA (GRIGIO) CON ADESIVI	L.H. FUEL TANK CAP (GREY) WITH STICKERS	CALOTTE RÉSERVOIR CARB GAUCHE (GRIS) AVEC DECALCOMANIE	KAPPE KRAFTSTOFFTANK LINKS (GRAU) MIT AUFKLEBER	CASQUETE DEPÓSITO GASOLINA IZQ. (GRIS) CON ADHESIVO		1	
8	65673P16018Z	CALOTTA SERB BENZ SINISTRA (ROSSO FH) CON ADESIVI	L.H. FUEL TANK CAP (RED FH) WITH STICKERS	CALOTTE RÉSERVOIR CARB GAUCHE (ROUGE FH) AVEC DECALCOMANIE	KAPPE KRAFTSTOFFTANK LINKES (ROT FH) MIT AUFKLEBER	CASQUETE DEPÓSITO GASOLINA IZQ. (ROJO FH) CON ADHESIVO		1	
8	65673P16019Z	CALOTTA SERB BENZINA SINISTRA (BLU KD) CON ADESIVI	L.H. FUEL TANK CAP (BLUE KD) WITH STICKERS	CALOTTE RÉSERVOIR CARB GAUCHE (BLEU KD) AVEC DECALCOMANIE	KAPPE KRAFTSTOFFTANK LINKES (BLAU KD) MIT AUFKLEBER	CASQUETE DEPÓSITO GASOLINA IZQ. (AZUL KD) CON ADHESIVO		1	
9	65674P16WS00	CALOTTA SERBATOIO BENZINA DESTRA (BIANCO WS)	R.H. FUEL TANK CAP (WHITE WS)	CALOTTE RÉSERVOIR CARBURANT DROITE (BLANC WS)	KAPPE KRAFTSTOFFTANK RECHT (WEIß WS)	CASQUETE DEPÓSITO GASOLINA DEL. (BLANCO WS)		1	
9	65674P16JS00	CALOTTA SERBATOIO BENZINA DESTRA (GRIGIO)	R.H. FUEL TANK CAP (GREY)	CALOTTE RÉSERVOIR CARBURANT DROITE (GRIS)	KAPPE KRAFTSTOFFTANK RECHTES (GRAU)	CASQUETE DEPÓSITO GASOLINA DER. (GRIS)		1	
9	65674P16FH00	CALOTTA SERBATOIO BENZINA DESTRA (ROSSO)	R.H. FUEL TANK CAP (RED)	CALOTTE RÉSERVOIR CARBURANT DROITE (ROUGE)	KAPPE KRAFTSTOFFTANK RECHTES (ROT)	CASQUETE DEPÓSITO GASOLINA DER. (ROJO)		1	
9	65674P16KD00	CALOTTA SERBATOIO BENZINA DESTRA (BLU KD)	R.H. FUEL TANK CAP (BLUE KD)	CALOTTE RÉSERVOIR CARBURANT DROITE (BLEU KD)	KAPPE KRAFTSTOFFTANK RECHT (BLAU KD)	CASQUETE DEPÓSITO GASOLINA DEL. (AZUL KD)		1	
9	65674P16016Z	CALOTTA SERB BENZ DESTRA (BIANCO WS) CON ADESIVI	R.H. FUEL TANK CAP (WHITE WS) WITH STICKERS	CALOTTE RÉSERVOIR CARB DROITE (BLANC WS) AVEC DECALCOMANIE	KAPPE KRAFTSTOFFTANK RECHT (WEIß WS) MIT AUFKLEBER	CASQUETE DEPÓSITO GASOLINA DEL. (BLANCO WS) CON ADHESIVO		1	
9	65674P16017Z	CALOTTA SERB BENZINA DESTRA (GRIGIO) CON ADESIVI	R.H. FUEL TANK CAP (GREY) WITH STICKERS	CALOTTE RÉSERVOIR CARB DROITE (GRIS) AVEC DECALCOMANIE	KAPPE KRAFTSTOFFTANK RECHTES (GRAU) MIT AUFKLEBER	CASQUETE DEPÓSITO GASOLINA DER. (GRIS) CON ADHESIVO		1	
9	65674P16018Z	CALOTTA SERBATOIO BENZINA DESTRA (ROSSO TL)	R.H. FUEL TANK CAP (RED)	CALOTTE RÉSERVOIR CARBURANT DROITE (ROUGE)	KAPPE KRAFTSTOFFTANK RECHTES (ROT)	CASQUETE DEPÓSITO GASOLINA DERECHO (ROJO)		1	
9	65674P16019Z	CALOTTA SERB BENZINA DESTRA (ROSSO) CON ADESIVI	R.H. FUEL TANK CAP (RED) WITH STICKERS	CALOTTE RÉSERVOIR CARB DROITE (ROUGE) AVEC DECALCOMANIE	KAPPE KRAFTSTOFFTANK RECHTES (ROT) MIT AUFKLEBER	CASQUETE DEPÓSITO GASOLINA DER. (ROJO) CON ADHESIVO		1	
10	65675P160000	PANNELLO SINISTRO	L.H. PANEL	PANNEAU GAUCHE	TAFEL LINKS	PANEL IZQUIERDA		1	

POS. NO. N. INDEX POS.	N. CODICE CODE NO. Nr. CODE ATRIKEL Nr. CODICO Nr.	DESCRIZIONE	DESCRIPTION	DESIGNATION	BEZEICHNUNG	DENOMINACION	NOTE NOTES NOTES MARKE NOTAS	Q.TA' CONF. Q.TY PACK. Q.TE EMB. M.GE PAK. C.AD PAQ.	
11	65676P160000	PANNELLO DESTRO	R.H. PANEL	PANNEAU DROITE	TAFEL RECHTS	PANEL DERECHA		1	
12	08012P160000	VITE (M5X16)	SCREW (M5X16)	VIS (M5X16)	SCHRAUBE (M5X16)	TORNILLO (M5X16)		1	
13	65691P160000	COPERCHIO SX	COVER L.H.	COUVERCLE GAUCHE	KUPPLUNG LINKER	TAPA IZQUIERDA		1	
14	65692P160000	COPERCHIO DX	COVER R.H.	COUVERCLE DROITE	KUPPLUNG RECHTER	TAPA DERECHA		1	
15	R90752031B	VITE (M6X14)	SCREW (M6X14)	VIS (M6X14)	SHARAUBE (M6X14)	TORNILLO (M6X14)		5	
16	R90752302B	RONDELLA NYLON	WASHER NYLON	RONDELLE EN NYLON	NYLON-UNTERLEGSCHIEBE	ARANDELA DE NYLON		5	
17	05533P16WS04	ADESIVO LOGO (BENELLI)	STICKER LOGO (BENELLI)	DÉCALCOMANIE LOGO (BENELLI)	AUFKLEBER LOGO (BENELLI)	ADHESIVO LOGO (BENELLI)		1	
17	05533P16JS04	ADESIVO LOGO (BENELLI)	STICKER LOGO (BENELLI)	DÉCALCOMANIE LOGO (BENELLI)	AUFKLEBER LOGO (BENELLI)	ADHESIVO LOGO (BENELLI)		1	
18	05532P260000	ADESIVO (OMOLOGAZIONE E5-E10)	STICKER (HOMOLOGATION E5-E10)	DÉCALCOMANIE (HOMOLOGATION E5-E10)	AUFKLEBER (RATIFIKATION E5-E10)	ADHESIVO (HOMOLOGACION E5-E10)		1	
19	05531P130005	ADESIVO (BENZINA SENZA PIOMBO)	STICKER (UNLEADED FUEL)	DÉCALCOMANIE (ESSENCE SANS PLOMB)	AUFKLEBER (BLEIFREI BENZIN)	ADHESIVO (GASOLINA SIN PLOMO)		1	
20	43038P250000	GOMMINO ANTIVIBRANTE	VIBRATION DAMPER PAD	JOINT EN CAOUTCHOUC ANTI-VIBRATION	SCHWINGUNGSDÄMPFERGUMMI	JUNTA DE GOMA ANTI-VIBRACIÓN		1	



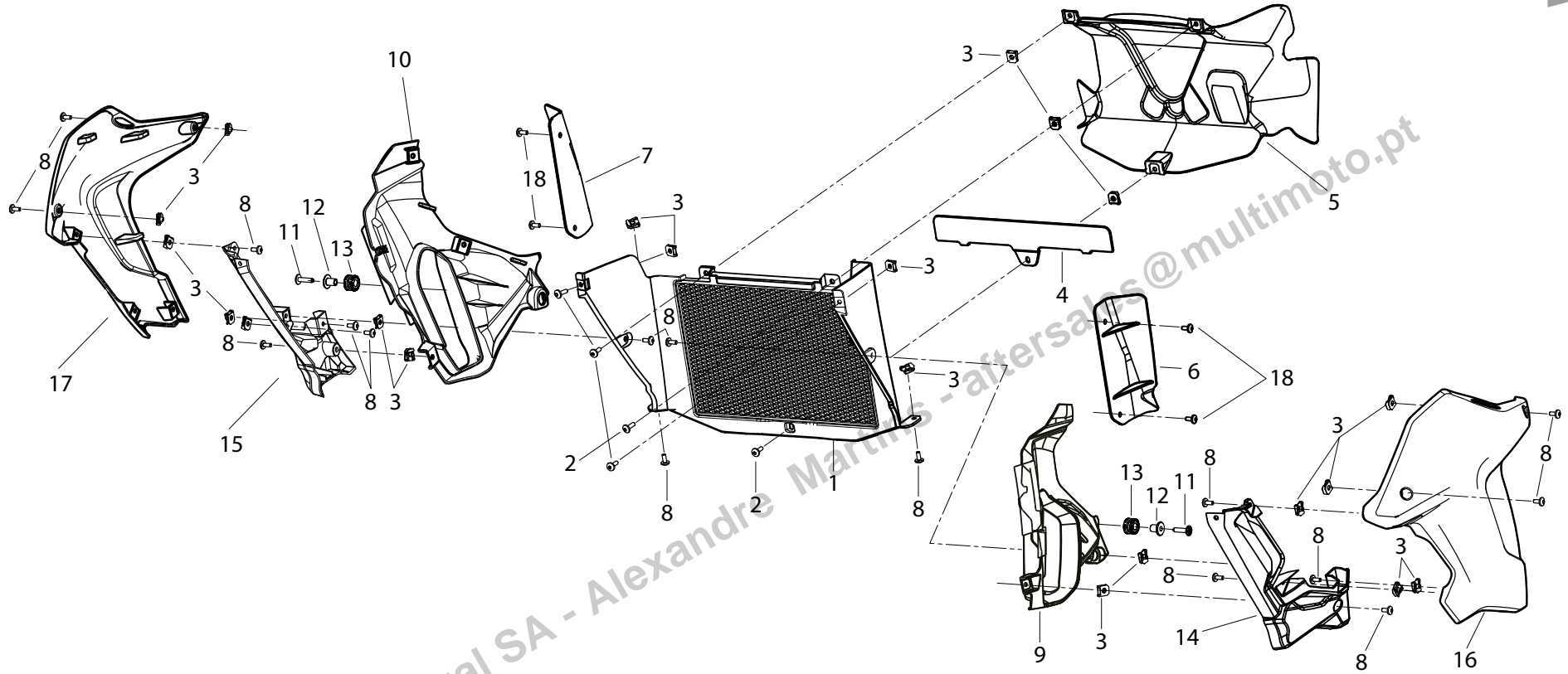

POS. NO. N. INDEX POS.	N. CODICE CODE NO. Nr. CODE ATRIKEL Nr. CODICO Nr.	DESCRIZIONE	DESCRIPTION	DESIGNATION	BEZEICHNUNG	DENOMINACION	NOTE NOTES NOTES MARKS NOTAS	Q.TA' CONF. Q.TY PACK. Q.TE EMB. M.GE PAK. C.AD PAQ.	
1	65681P160000	PROTEZIONE RADIATORE	RADIATOR PROTECTION	PROTECTION RADIATEUR	HEIZKÖRPER SCHUTZ	PROTECCIÓN RADIATOR		1	
2	08012P160000	VITE (M5X16)	SCREW (M5X16)	VIS (M5X16)	SCHRAUBE (M5X16)	TORNILLO (M5X16)		1	
3	65624P160000	CLIP FISSAGGIO RAPIDO (M5)	QUIK FASTENING (M5)	FIXATION RAPIDE (M5)	SCHNELLEBEFESTIGUNG (M5)	FIJACIÓN RÁPIDA (M5)		1	
4	65685P160000	STAFFA	BRACKET	BRIDE	BÜGEL	SOPORTE		1	
5	65682P160000	CONVOGLIATORE	MANIFOLD	CONVOYEUR	FÖRDERER	ENCANALADOR		1	
6	65683P160000	STAFFA SINISTRA	L.H. BRACKET	BRIDE GAUCHE	LINKER BÜGEL	SOPORTE IZQUIERDA		1	
7	65684P160000	STAFFA DESTRA	R.H. BRACKET	BRIDE GAUCHE	BÜGEL RECHTER	SOPORTE DERECHA		1	
8	08012P160000	VITE (M6X14)	SCREW (M6X14)	VIS (M6X14)	SHARAUBE (M6X14)	TORNILLO (M6X14)		1	
9	65307P160010	CONVOGLIATORE SINISTRO	L.H. MANIFOLD	CONVOYEUR GAUCHE	FÖRDERER LINK	ENCANALADOR IZQUIERDO		1	
10	65308P160010	CONVOGLIATORE DESTRO	R.H. AIR MANIFOLD	CONVOYEUR D'AIR DROITE	LUFTFÖRDERER RECHT	ENCANALADOR DERECHO		1	
11	R320452063000	VITE (M6X25)	SCREW (M6X25)	VIS (M6X25)	SHARAUBE (M6X25)	TORNILLO (M6X25)		1	
12	140035040010	BOCCOLA SUPERIORE	UPPER BUSH	DOUILLE SUPÉRIEURE	OBERER BUCHSE	CASQUILLO SUPERIOR		1	
13	R180479181000	GOMMINO	RUBBER PAD	JOINT EN CAOUTCHOUC	GUMMISTÜCK	JUNTA DE GOMA		1	
14	65621P160000	FIANCHETTO SX (GRIGIO)	L.H. BODY PANEL (GREY)	PANNEAU LATÉRAL GAUCHE (GRIS)	LINK SEITENABDECKUNG (GRAU)	LATERAL IZQ. (GRIS)		1	
15	65622P160000	FIANCHETTO DX (GRIGIO)	R.H. BODY PANEL (GREY)	PANNEAU LATÉRAL DROITE (GRIS)	RECHT SEITENABDECKUNG (GRAU)	PANEL LATERAL DERECHO (GRIS)		1	
16	65632P16WS00	CARENATURA SUPERIORE ESTERNA SX (BIANCO WS)	L.H. OUTER UPPER FAIRING (WHITE WS)	CARÉNAGE SUP. EXTERNE GAUCHE (BLANC WS)	SCHALE OBERER ÄÜBERE LINKER (WEIß WS)	BASTIDOR SUPERIOR EXTERIOR IZQ. (BLANCO WS)		1	
16	65632P16JS00	CARENATURA SUPERIORE ESTERNA SX (GRIGIO)	L.H. OUTER UPPER FAIRING GRAY	CARÉNAGE SUPÉRIEURE EXTERNE GAUCHE (GRIS)	SCHALE OBERER ÄÜBERE LINKER (GRAU)	BASTIDOR SUPERIOR EXTERIOR IZQ. (GRIS)		1	
16	65632P16FH00	CARENATURA SUPERIORE ESTERNA SX (ROSSO FH)	L.H. OUTER UPPER FAIRING (RED FH)	CARÉNAGE SUP. EXTERNE GAUCHE (ROUGE FH)	SCHALE OBERER ÄÜBERE LINKER (ROT FH)	BASTIDOR SUPERIOR EXTERIOR IZQ. (ROJO FH)		1	
16	65632P16KD00	CARENATURA SUPERIORE ESTERNA SX (BLU KD)	L.H. OUTER UPPER FAIRING (BLEU KD)	CARÉNAGE SUPÉRIEURE EXTERNE GAUCHE (BLEU KD)	SCHALE OBERER ÄÜBERE LINKER (BLAU KD)	BASTIDOR SUPERIOR EXTERIOR IZQ. (AZUL KD)		1	
16	R999999999999	CARENATURA SUP. ESTERNA SX (BIANCO WS) CON ADESIVI	L.H. OUTER UPPER FAIRING (WHITE WS) WITH STICKERS	CARÉNAGE SUP. EX. GAUCHE (BLANC WS) AVEC DÉCALCOMANIE	SCHALE OBERER ÄÜBERE LINKER (WEIß WS) MIT AUFKLEBER	BASTIDOR SUP. EX. IZQ. (BLANCO WS) CON ADHESIVO		1	
16	65632P16023Z	CARENATURA SUP. ESTERNA SX (GRIGIO) CON ADESIVI	L.H. OUTER UPPER FAIRING (GREY) WITH STICKERS	CARÉNAGE SUP. EX. GAUCHE (GRIS) AVEC DÉCALCOMANIE	SCHALE OBERER ÄÜBERE LINKS (GRAU) MIT AUFKLEBER	BASTIDOR SUPERIOR EXTERIOR IZQ. (GRIS) CON ADHESIVO		1	
16	65632P16024Z	CARENATURA SUP. ESTERNA SX (ROSSO FH) CON ADESIVI	L.H. OUTER UPPER FAIRING (RED FH) WITH STICKERS	CARÉNAGE SUP. EX. GAUCHE (ROUGE FH) AVEC DÉCALCOMANIE	SCHALE OBERER ÄÜBERE LINKER (ROT FH) MIT AUFKLEBER	BASTIDOR SUP. EX. IZQ. (ROJO FH) CON ADHESIVO		1	
16	65632P16025Z	CARENATURA SUP. ESTERNA SX (BLU KD) CON ADESIVI	L.H. OUTER UPPER FAIRING (BLEU KD) WITH STICKERS	CARÉNAGE SUP. EX. GAUCHE (BLEU KD) AVEC DÉCALCOMANIE	SCHALE OBERER ÄÜBERE LINKER (BLAU KD) MIT AUFKLEBER	BASTIDOR SUP. EXTERIOR IZQ. (AZUL KD) CON ADHESIVO		1	
17	65633P16WS00	CARENATURA SUPERIORE ESTERNA DX (BIANCO WS)	R.H. OUTER UPPER FAIRING (WHITE WS)	CARÉNAGE SUPÉRIEURE EXTERNE DROITE (BLANC WS)	SCHALE OBERER ÄÜBERE RECHTE (WEIß WS)	BASTIDOR SUPERIOR EXTERIOR DER. (BLANCO WS)		1	

POS. NO. N. INDEX POS.	N. CODICE CODE NO. Nr. CODE ATRIKEL Nr. CODICO Nr.	DESCRIZIONE	DESCRIPTION	DESIGNATION	BEZEICHNUNG	DENOMINACION	NOTE NOTES NOTES MARKE NOTAS	Q.TA' CONF. Q.TY PACK. Q.TE EMB. M.GE PAK. C.AD PAQ.	
17	65633P16JS00	CARENATURA SUPERIORE ESTERNA DX (GRIGIO)	R.H. OUTER UPPER FAIRING (GRAY)	CARÉNAGE SUPÉRIEURE EXTERNE DROITE (GRIS)	SCHALE OBERER ÄÜBERE RECHTE (GRAU)	BASTIDOR SUPERIOR EXTERIOR DER. (GRIS)		1	
17	65633P16FH00	CARENATURA SUPERIORE ESTERNA DX (ROSSO FH)	R.H. OUTER UPPER FAIRING (RED FH)	CARÉNAGE SUPÉRIEURE EXTERNE DROITE (ROUGE FH)	SCHALE OBERER ÄÜBERE RECHTE (ROT FH)	BASTIDOR SUPERIOR EXTERIOR DER. (ROJO FH)		1	
17	65633P16KD00	CARENATURA SUPERIORE ESTERNA DX (BLU KD)	R.H. OUTER UPPER FAIRING (BLEU KD)	CARÉNAGE SUPÉRIEURE EXTERNE DROITE (BLEU KD)	SCHALE OBERER ÄÜBERE RECHTE (BLAU KD)	BASTIDOR SUPERIOR EXTERIOR DER. (AZUL KD)		1	
17	65633P16022Z	CARENATURA SUP. ESTERNA DX (BIANCO WS) CON ADESIVI	R.H. OUTER UPPER FAIRING (WHITE WS) WITH STICKERS	CARÉNAGE SUP. EX. DROITE (BLANC WS) AVEC DÉCALCOMANIE	SCHALE OBERER ÄÜBERE RECHTE (WEIß WS) MIT AUFKLEBER	BASTIDOR SUPERIOR EXTERIOR DER. (BLANCO WS) CON ADHESIVO		1	
17	65633P16023Z	CARENATURA SUPERIORE ESTERNA DX (GRIGIO) CON ADESIVI	R.H. OUTER UPPER FAIRING (GREY) WITH STICKERS	CARÉNAGE SUP. EXTERNE DROITE (GRIS) AVEC DÉCALCOMANIE	SCHALE OBERER ÄÜBERE RECHTE (GRAU) MIT AUFKLEBER	BASTIDOR SUPERIOR EXTERIOR DER. (GRIS) CON ADHESIVO		1	
17	65633P16024Z	CARENATURA SUP. ESTERNA DX (ROSSO FH) CON ADESIVI	R.H. OUTER UPPER FAIRING (RED FH) WITH STICKERS	CARÉNAGE SUP. EX. DROITE (ROUGE FH) AVEC DÉCALCOMANIE	SCHALE OBERER ÄÜBERE RECHTE (ROT FH) MIT AUFKLEBER	BASTIDOR SUPERIOR EXTERIOR DER. (ROJO FH) CON ADHESIVO		1	
17	65633P16025Z	CARENATURA SUPERIORE ESTERNA DX (BLU KD) CON ADESIVI	R.H. OUTER UPPER FAIRING (BLEU KD) WITH STICKERS	CARÉNAGE SUP. EX. DROITE (BLEU KD) AVEC DÉCALCOMANIE	SCHALE OBERER ÄÜBERE RECHTE (BLAU KD) MIT AUFKLEBER	BASTIDOR SUPERIOR EXTERIOR DER. (AZUL KD) CON ADHESIVO		1	
18	R90750491B	VITE (M6X14)	SCREW (M6X14)	VIS (M6X14)	SHARAUBE (M6X14)	TORNILLO (M6X14)		1	



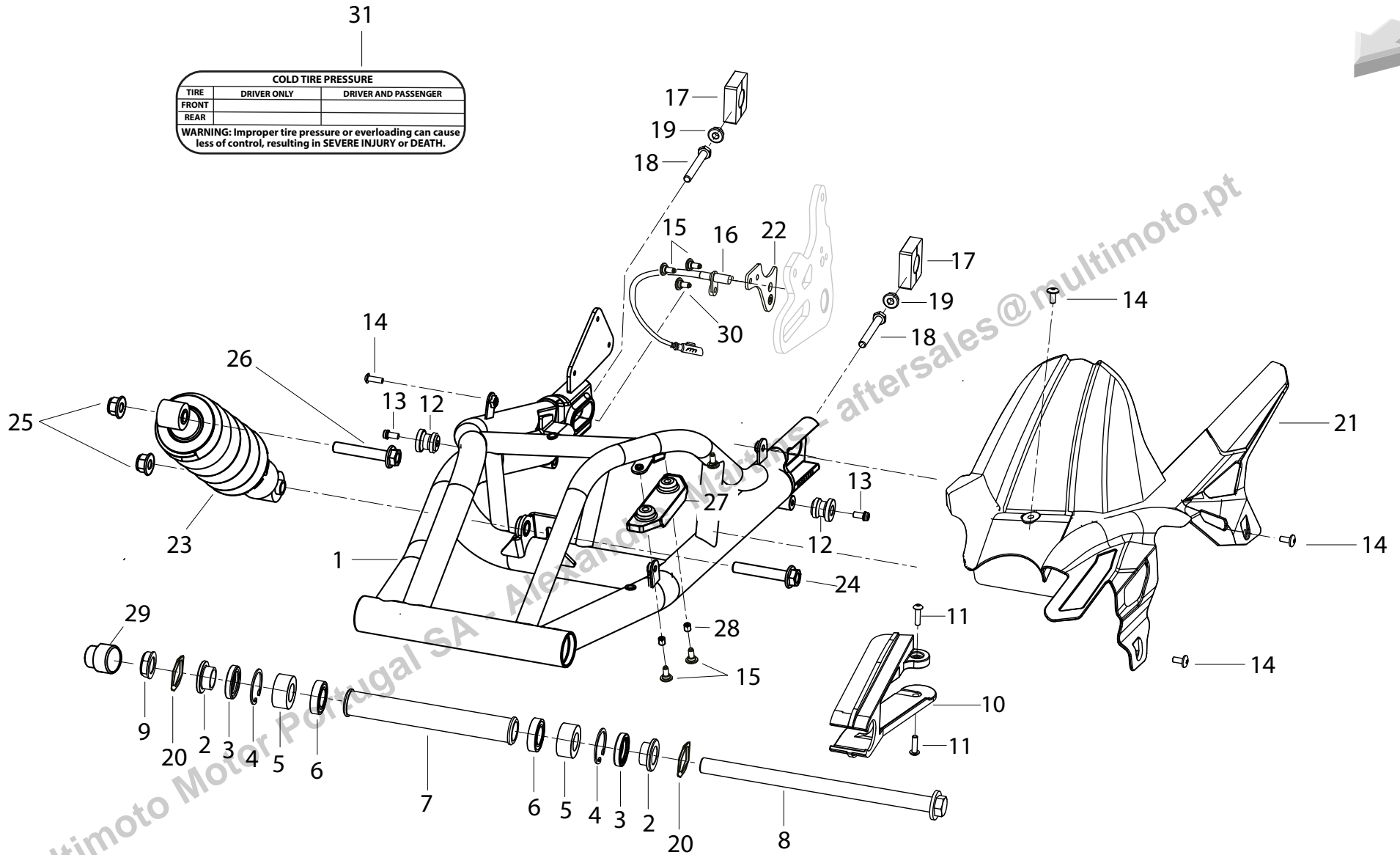

POS. NO. N. INDEX POS.	N. CODICE CODE NO. Nr. CODE ATRIBEL Nr. CODICO Nr.	DESCRIZIONE	DESCRIPTION	DESIGNATION	BEZEICHNUNG	DENOMINACION	NOTE NOTES NOTES MARKE NOTAS	Q.TA' CONF. Q.TY PACK. Q.TE EMB. M.GE PAK. C.AD PAQ.	
1	53100P160100	FORCELLONE	SWINGARM	FOURCHE	SCHWINGE	BASCULANTE		1	
2	53006P100100	BOCCOLA	BUSH	DOUILLE	BUCHSE	CASQUILLO		1	
3	53220P100000	PARAOILIO	OIL SEAL	BAGUE D'ETANCHEITE	WELLENDICHTRING	RETEN DE ACEITE		1	
4	R320452053000	ANELLO SEEGER	CIRCLIP	CIRCLIP	SEEGERRING	ANILLO SEEGER		1	
5	R320452210000	CUSCINETTO	BEARING	ROULEMENT	LAGER	COJINETE		1	
6	R320452211000	CUSCINETTO	BEARING	ROULEMENT	LAGER	COJINETE		1	
7	53005P100000	DISTANZIALE INTERNO	INNER SPACER	ENTRETOISE INTERNE	INNERES DISTANZSTÜCK	DISTANCIADOR INTERIOR		1	
8	53001P160000	PERNO FORCELLONE	SWINGARM PIVOT	AXE FOURCHE ARRIÈRE	SCHWINGENBOLZEN	EJE BASCULANTE		1	
9	08051P100100	DADO	NUT	ECROU	MUTTER	TUERCA		1	
10	R320427030000	PATTINO CATENA INFERIORE	LOWER CHAIN SLIDING SHOE	PATIN CHAÎNE INFÉRIEURE	UNTERER KETTENGLEITSCHUH	PATÍN CADENA INFERIOR		1	
11	R90752268E	VITE (M6X15.2)	SCREW (M6X15.2)	VIS (M6X15.2)	SHARAUBE (M6X15.2)	TORNILLO (M6X15.2)		5	
12	53021P250000	NOTTOLINO FORCELLONE	SWINGARM PAWLS	CLIQUETS FOURCHE	KLINKEN SCHWINGE	TRINQUETES BASCULANTE		1	
13	R90750531B	VITE (M6X25)	SCREW (M6X25)	VIS (M6X25)	SHARAUBE (M6X25)	TORNILLO (M6X25)		1	
14	R90752031B	VITE (M6X14)	SCREW (M6X14)	VIS (M6X14)	SHARAUBE (M6X14)	TORNILLO (M6X14)		5	
15	R700052157000	VITE (M6X16)	SCREW (M6X16)	VIS (M6X16)	SHARAUBE (M6X16)	TORNILLO (M6X16)		5	
16	55710P250000	SENSORE ABS RUOTA POSTERIORE	SENSOR ABS REAR WHEEL	CAPTEUR ABS ROUE ARRIÈRE	SENSOR ABS HINTERER	SENSOR ABS RUEDA TRASERA		1	
17	53231P100001	PATTINO REGISTRO CATENA	CHAIN ADJUSTER SLIDING SHOE	RÉGLAGE CHAÎNE	EINSTELLER KETTE	REGULACIÓN CADENA		1	
18	R320052081000	VITE (M8)	SCREW (M8)	VIS (M8)	SHARAUBE (M8)	TORNILLO (M8)		1	
19	R320052054000	DADO (M8)	NUT (M8)	ECROU (M8)	MUTTER (M8)	TUERCA (M8)		1	
20	43025J010050	RONDELLA	WASHER	RONDELLE	UNTERLEGSCHIEBE	ARANDELA		1	
21	60101P160000	PARAFANGO POSTERIORE	REAR MUDGUARD	GARDE -BOUE ARRIÈRE	HINTERERS SCHUTZBLECH	GUARDABARROS TRASERO		1	
22	55420P160002	PIASTRA	PLATE	PLAQUE	PLATTE	SOPORTE		1	
23	63800P160007	AMMORTIZZATORE POSTERIORE	REAR SHOCK ABSORBER	AMORTISSEUR ARRIÈRE	HINTERER STOßDÄMPFER	AMORTIGUADOR TRASERO		1	
24	08011M150100	VITE (M12X75)	SCREW (M12X75)	VIS (M12X75)	SCHRAUBE (M12X75)	TORNILLO (M12X75)		1	

POS. NO. N. INDEX POS.	N. CODICE CODE NO. Nr. CODE ATRÍKEL Nr. CODICO Nr.	DESCRIZIONE	DESCRIPTION	DESIGNATION	BEZEICHNUNG	DENOMINACION	NOTE NOTES NOTES MARKE NOTAS	Q.TA' CONF. Q.TY PACK. Q.TE EMB. M.GE PAK. C.AD PAQ.	
25	B0417121254H	DADO (M12X1.25)	NUT (M12X1.25)	ECROU (M12X1.25)	MUTTER (M12X1.25)	TUERCA (M12X1.25)		1	
26	08018P160000	VITE (M12X65)	SCREW (M12X65)	VIS (M12X65)	SCHRAUBE (M12X65)	TORNILLO (M12X65)		1	
27	53018P100000	PATTINO CATENA FORCELLONE	SWINGARM CHAIN SLIDING SHOE	PATIN CHAÎNE FOURCHE	KETTENGLEITSCHUN SCHWINGE	PATÍN CADENA BASCULANTE		1	
28	53022P100000	DISTANZIALE	SPACER	ENTRETOISE	DISTANZSTÜCK	DISTANCIAL		1	
29	53018P160000	GOMMINO	RUBBER PAD	JOINT EN CAOUTCHOUC	GUMMISTÜCK	JUNTA DE GOMA		1	
30	R90750641B	VITE (TEF M6X14)	SCREW (TEF M6X14)	VIS (TEF M6X14)	SHRAUBE (TEF M6X14)	TORNILLO (TEF M6X14)		5	
31	05581N220001	ADESIVO INFORMATIVO	INFORMATION STICKER	AUTOCOLLANT D'INFORMATION	INFORMATIONSSICKER	ETIQUETA DE INFORMACIÓN		1	



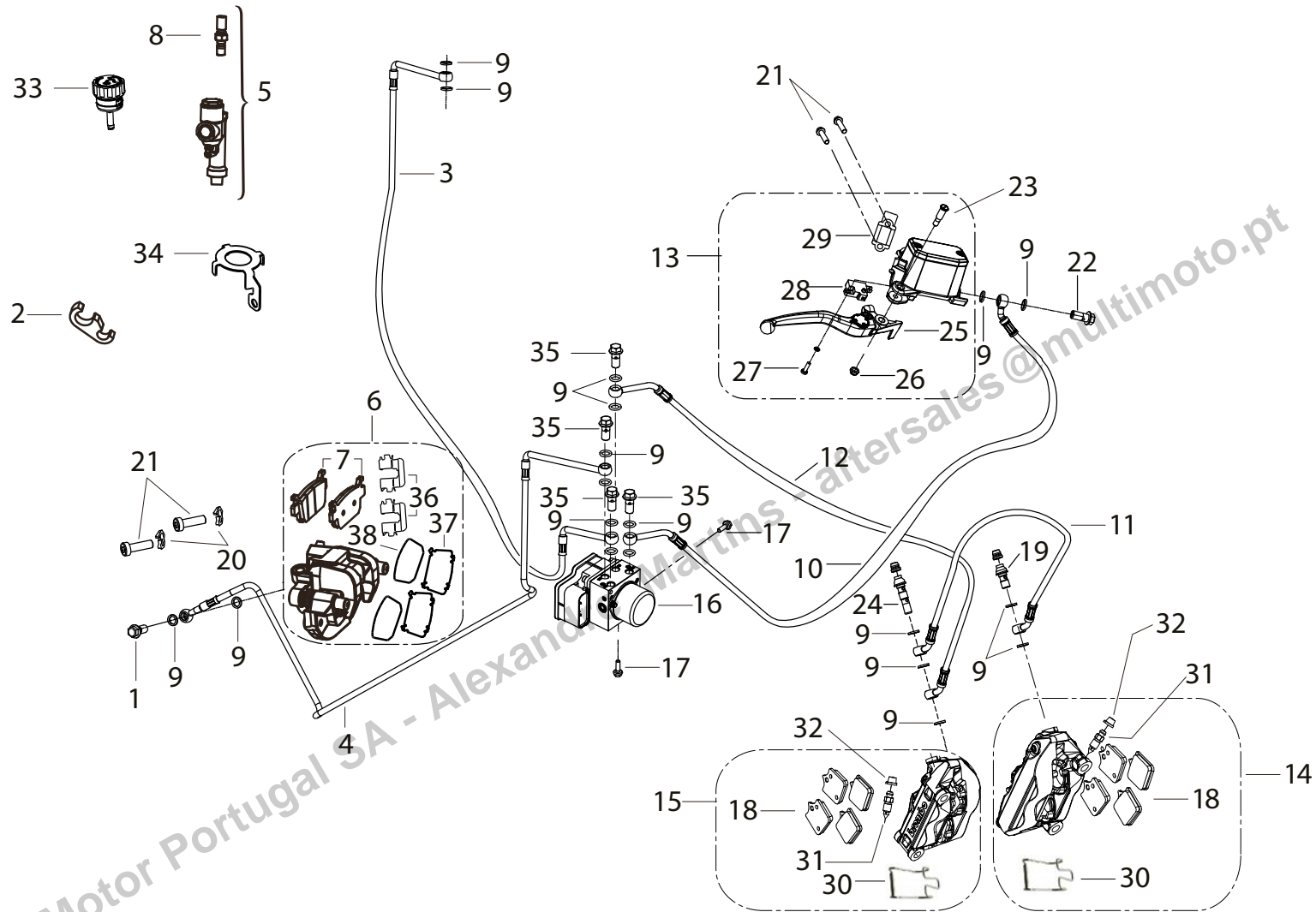

POS. NO. N. INDEX POS.	N. CODICE CODE NO. Nr. CODE ATRIKEL Nr. CODICO Nr.	DESCRIZIONE	DESCRIPTION	DESIGNATION	BEZEICHNUNG	DENOMINACION	NOTE NOTES NOTES MARKER NOTAS	Q.TA' CONF. Q.TY PACK. Q.TE EMB. M.GE PAK. C.AD PAQ.	
1	55037J410000	VITE SPECIALE	SPECIAL SCREW	VIS SPÉCIALE	SPEZIALSCHRAUBE	TORNILLO ESPECIAL		1	
2	45044P160000	FASCETTA A MOLLA	SPRING HOSE CLAMP	COLLIER RESSORT	FEDERSCHELLE	ABRAZADERA A MUELLE		1	
3	55240P160001	TUBO POMPA FRENO POSTERIORE - CENTRALINA ABS	REAR BRAKE PUMP LINE - ABS CONTROL UNIT	TUBE POMPE FREIN ARRIÈRE - CENTRALE ABS	HINTERE PUMPE BREMSLEITUNG - STEUERGEHÄUSE ABS	TUBO BOMBA FRENO TRASERO - CENTRALITA ABS		1	
4	55270P160001	TUBO PINZA FRENO POSTERIORE - CENTRALINA ABS	REAR BRAKE CALIPER LINE - ABS CONTROL UNIT	TUBE FREIN ARRIÈRE - CENTRALE ABS	HITERE BREMSZANGE BREMSLEITUNG - STEUERGEHÄUSE ABS	TUBO PINZA FRENO TRASERO - CENTRALITA ABS		1	
5	55400P160000	POMPA FRENO POSTERIORE	REAR BRAKE PUMP	POMPE FREIN ARRIÈRE	PUMPE FÜR HITERRADBREMSE	BOMBA FRENO TRASERO		1	
6	55500P160000	PINZA FRENO POSTERIORE	REAR BRAKE CALIPER	PINCE FREIN ARRIÈRE	HITERE BREMSZANGE	PINZA FRENO TRASERO		1	
7	R320463113000	COPPIA PASTIGLIE FRENO (POSTERIORI)	BRAKE PADS PAIR (REAR)	PAIRE DE PLAQUETTES FREIN (ARRIÈRE)	PAAR BREMSBELÄGE (RÜCKSEITE)	PAR PASTILLAS (TRASERO)		1	
8	55300P160000	IDROSTOP POSTERIORE	REAR HYDROSTOP	HYDROSTOP ARRIERE	HINTERER HYDROSTOPP	HIDROSTOP TRASERO		1	
9	45078P300000	GUARNIZIONE	GASKET	GARNITURE	DICHTUNG	JUNTA		1	
10	45240P160002	TUBO POMPA FRENO ANTERIORE - CENTRALINA ABS	FRONT BRAKE PUMP TUBE - ABS CONTROL UNIT	TUBE POMPE FREIN AVANT - CENTRALE ABS	VORDERE PUMPE BREMSLEITUNG - STEUER-GEHÄUSE ABS	TUBO BOMBA FRENO DELANTERO - CENTRALITA ABS		1	
11	45250P160000	TUBO FRENO ANTERIORE	FRONT BRAKE TUBE	TUBE FREIN AVANT	VORDERE BREMSLEITUNG	TUBO FRENO DELANTERO		1	
12	45270P160002	TUBO FRENO ANTERIORE	FRONT BRAKE TUBE	TUBE FREIN AVANT	VORDERE BREMSLEITUNG	TUBO FRENO DELANTERO		1	
13	45400P250114	POMPA FRENO ANTERIORE COMPLETA	FRONT BRAKE PUMP COMPLET	POMPE FREIN AVANT COMPLET	PUMPE FÜR VORDERRADBREMSE KOMPLET	BOMBA FRENO DELANTERO COMPLETA		1	
14	45500P160000	PINZA FRENO SINISTRA (RADIALE)	L.H. BRAKE CALIPER (RADIAL)	PINCE FREIN GAUCHE (RADIAL)	LINKE BREMSZANGE (RADIAL)	PINZA FRENO IZQ.(RADIAL)		1	
15	45600P160000	PINZA FRENO DESTRA (RADIALE)	R.H. BRAKE CALIPER (RADIAL)	PINCE FREIN DROIT (RADIAL)	RECHTE BREMSZANGE (RADIAL)	PINZA FRENO DER.(RADIAL)		1	
16	45700P250000	UNITÀ IDRAULICA ABS	HYDRAULIC UNIT ABS	UNITÉ HYDRAULIQUE ABS	HYDRAULIKEINHEIT ABS	UNIDAD HIDRÁULICA ABS		1	
17	B01090601264	VITE (M6X12)	SCREW (M6X12)	VIS (M6X12)	SHARAUBE (M6X12)	TORNILLO (M6X12)		1	
18	R0000001127000	COPPIA PASTIGLIE FRENO (ANTERIORE)	BRAKE PADS PAIR (FRONT)	PAIRE DE PLAQUETTES FREIN (AVANT)	PAAR BREMSBELÄGE (VORDERRADBREMSE)	PAR PASTILLAS FRENO (DELANTERO)		1	
19	45037P300000	VITE SPECIALE	SPECIAL SCREW	VIS SPÉCIALE	SPEZIALSCHRAUBE	TORNILLO ESPECIAL		1	
20	B0700000080H	RONDELLA ELASTICA	ELASTIC WASHER	RONDELLE ELASTIQUE	ELASTISCHER RING	ARANDELA ELÁSTICA		1	
21	R90751451B	VITE (TCEI M8X25)	SCREW (TCEI M8X25)	VIS (TCEI M8X25)	SHARAUBE (TCEI M8X25)	TORNILLO (TCEI M8X25)		1	
22	45037J000000	VITE FORATA FRENI	EYE SCREW BRAKES	VIS À TROU FREIN	ÖSENSCHRAUBE BREMSE	TORNILLO TALADRADO FRENOS		1	
23	45024P300000	VITE SPECIALE	SPECIAL SCREW	VIS SPÉCIALE	SPEZIALSCHRAUBE	TORNILLO ESPECIAL		1	
24	45037P150000	VITE SPECIALE	SPECIAL SCREW	VIS SPÉCIALE	SPEZIALSCHRAUBE	TORNILLO ESPECIAL		1	

POS. NO. N. INDEX POS.	N. CODICE CODE NO. Nr. CODE ATRIKEL Nr. CODICO Nr.	DESCRIZIONE	DESCRIPTION	DESIGNATION	BEZEICHNUNG	DENOMINACION	NOTE NOTES NOTES MARKE NOTAS	Q.TA' CONF. Q.TY PACK. Q.TE EMB. M.GE PAK. C.AD PAQ.	
25	45020P360000	LEVA COMANDO FRENO ANTERIORE (NERO)	FRONT BRAKE CONTROL LEVER (BLACK)	LEVIER DE COMMANDE FREIN AVANT (NOIR)	BREMSHEBEL VORDERER (SCHWARZ)	LEVA MANDO FRENO DELANTERA (NEGRO)		1	
26	R030458034000	DADO AUTOBLOCCANTE (M6)	NUT, SELF - LOCKING (M6)	ECROU AUTO BLOCANT (M6)	SELBSTSICHERNDE MUTTER (M6)	TUERCA AUTOBLOCANTE (M6)		10	
27	B02040401225	VITE (M4X12)	SCREW (M4X12)	VIS (M4X12)	SHARAUBE (M4X12)	TORNILLO (M4X12)		1	
28	45300P360000	MICROINTERRUTTORE	MICROSWITCH	MICRO-INTERRUPTEUR	MIKROSCHALTER	MICROINTERRUPTOR		1	
29	45023P250000	CAVALLOTTO	BRACKET	CAVALIER	BÜGELBOLZEN	PERNO DE U		1	
30	45017S010000	MOLLA	SPRING	RESSORT	FEDER	MUELLE		1	
31	45019N3CT000	SPURGO	BLEED	VIDANGE	ABLAß	PURGA		1	
32	45021B510000	GOMMINO	RUBBER PAD	JOINT EN CAOUTCHOUC	GUMMISTÜCK	JUNTA DE GOMA		1	
33	55140P260000	SERBATOIO OLIO FRENI	OIL TANK BRAKE	RÉSERVOIR D' HUILE FREIN	ÖLTANKBREMSE	DEPÓSITO ACEITE FRENO		1	
34	57041V030001	PIASTRINO	PLATE	PLAQUETTE	PLÄTTCHEN	LAMINA		1	
35	55037P250000	VITE SPECIALE	SPECIAL SCREW	VIS SPÉCIALE	SPEZIALSCHRAUBE	TORNILLO ESPECIAL		1	
36	55018P100000	SUPPORTO ELASTICO	SPRING PAD	SUPPORT ÉLASTIQUE	ELASTISCHE UNTERSTÜTZUNG	SOPORTE ELASTICO		1	
37	55099P100000	PIASTRA	PLATE	PLAQUE	PLATTE	SOPORTE		1	
38	55098P100000	ISOLANTE TERMICO	THERMIC INSULATOR	ISOLANT THERMIQUE	WÄRMEISOLATION	AISLAMIENTO TÉRMICO		1	



 **CIRCUITO DI RAFFREDDAMENTO**

 **COOLING CIRCUIT**

 **CIRCUIT DE REFRIGERATION**

 **KÜHLREISLAUF**

 **CIRCUITO REFRIGERADOR**

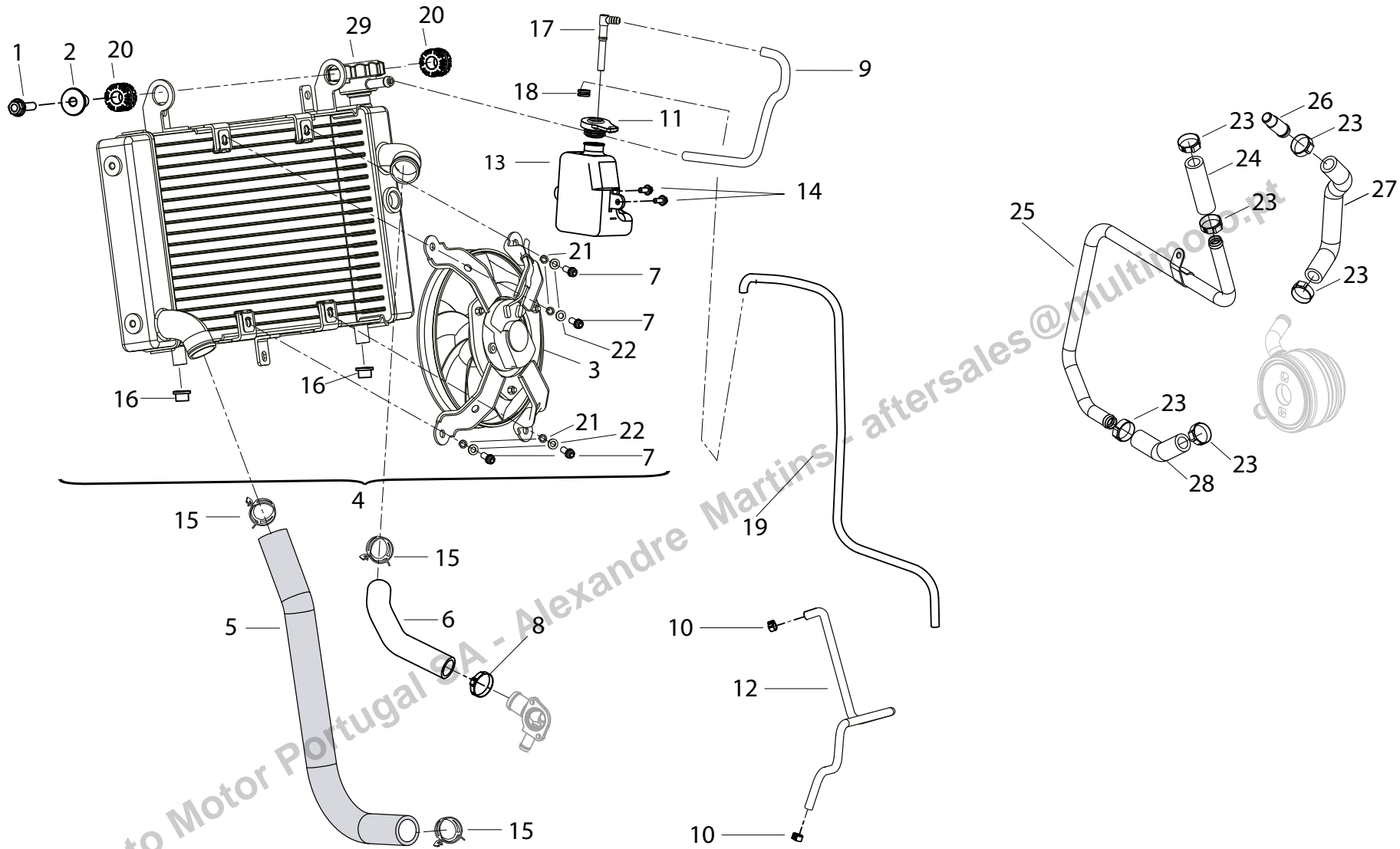

POS. NO. N. INDEX POS.	N. CODICE CODE NO. Nr. CODE ATRIKEL Nr. CODICO Nr.	DESCRIZIONE	DESCRIPTION	DESIGNATION	BEZEICHNUNG	DENOMINACION	NOTE NOTES NOTES MARKE NOTAS	Q.TA' CONF. Q.TY PACK. Q.TE EMB. M.GE PAK. C.AD PAQ.	
1	R320052143000	VITE (M6X25)	SCREW (M6X25)	VIS (M6X25)	SHARAUBE (M6X25)	TORNILLO (M6X25)		1	
2	R320052134000	BOCCOLA	BUSH	DOUILLE	BUCHSE	CASQUILLO		1	
3	270786280000	ELETTROVENTOLA	ELECTRIC FAN	ELECTRO-VENTILATEUR	ELEKTROLÜFTERRAD	ELECTROVENTILADOR		1	
4	279126280020	RADIATORE ACQUA COMPLETO	COMPLETE WATER RADIATOR	COMPLET RADIATEUR D'EAU	KOMPLETT WASSERKUEHLER	RADIATOR AGUA COMPLETO		1	
5	R320483059000	MANICOTTO	HOSE	MANCHON	MUFFE	MANGUETA		1	
6	06251P160000	MANICOTTO	HOSE	MANCHON	MUFFE	MANGUETA		1	
7	B0101060102H	VITE (M6X10)	SCREW (M6X10)	VIS (M6X10)	SCHRAUBE (M6X10)	TORNILLO (M6X10)		#N/D	
8	496505010000	FASCETTA A VITE	SCREW HOSE CLAMP	COLLIER À VISSER	SCHRAUBENSHELLE	ABRAZADERA A TORNILLO		1	
9	06223P160000	TUBO	TUBE	TUBE	ROHR	TUBO		1	
10	R320052151000	FASCETTA	CLAMP	COLLIER	SHELLE	ABRAZADERA		1	
11	R310083030000	TAPPO SERBATOIO ACQUA	WATER TANK CAP	BOUCHON DE RÉSERVOIR L'EAU	TANKVERSCHLUB WASSER	TAPÓN DEPÓSITO AGUA		1	
12	R320090050000	TUBO	TUBE	TUBE	ROHR	TUBO		1	
13	06111P250000	SERBATOIO ACQUA	WATER TANK	RÉSERVOIR D'EAU	WASSERTANK	DEPÓSITO AGUA		1	
14	B01090601262	VITE (M6X12)	SCREW (M6X12)	VIS (M6X12)	SHARAUBE (M6X12)	TORNILLO (M6X12)		1	
15	06103P160000	FASCETTA	CLAMP	COLLIER	SHELLE	ABRAZADERA		1	
16	270011170000	BOCCOLA	BUSH	DOUILLE	BUCHSE	CASQUILLO		1	
17	R310083031000	TUBO ASPIRAZIONE	INTAKE TUBE	TUBE D'ASPIRATION	ROHR EILNA	TUBO DE ASIRACIÓN		1	
18	43038P250000	GOMMINO ANTIVIBRANTE	VIBRATION DAMPER PAD	JOINT EN CAOUTCHOUC ANTI-VIBRATION	SCHWINGUNGSDÄMPFERGUMMI	JUNTA DE GOMA ANTI-VIBRACIÓN		1	
19	R320083056000	TUBO	TUBE	TUBE	ROHR	TUBO		1	
20	R180479181000	GOMMINO	RUBBER PAD	JOINT EN CAOUTCHOUC	GUMMISTÜCK	JUNTA DE GOMA		1	
21	B0700000060H	RONDELLA	WASHER	RONDELLE	UNTERLEGSCHIEBE	ARANDELA		1	
22	B0703000060H	RONDELLA	WASHER	RONDELLE	UNTERLEGSCHIEBE	ARANDELA		1	
23	150226280000	FASCETTA	CLAMP	COLLIER	SHELLE	ABRAZADERA		1	
24	150186280000	TUBO	TUBE	TUBE	ROHR	TUBO		1	

POS. NO. N. INDEX POS.	N. CODICE CODE NO. Nr. CODE ATRÍKEL Nr. CODICO Nr.	DESCRIZIONE	DESCRIPTION	DESIGNATION	BEZEICHNUNG	DENOMINACION	NOTE NOTES NOTES MARKE NOTAS	Q.TA' CONF. Q.TY PACK. Q.TE EMB. M.GE PAK. C.AD PAQ.	
25	150216280000	MANICOTTO	HOSE	MANCHON	MUFFE	MANGUETA		1	
26	150176280000	SPINA	PIN	GOUPILLE	STIFT	PASADOR		1	
27	150206280000	MANICOTTO	HOSE	MANCHON	MUFFE	MANGUETA		1	
28	150196280000	MANICOTTO	HOSE	MANCHON	MUFFE	MANGUETA		1	
29	279185050000	TAPPO RADIATORE	RADIATOR CAP	BOUCHON RADIATEUR	VERSCHLUß FÜR KÜHLER	TAPÓN RADIADOR		1	



Multimoto Motor Portugal SA - Alexandre Martins - aftersales@multimoto.pt

POS. NO. N. INDEX POS.	N. CODICE CODE NO. Nr. CODE ATRIBEL NR. CODICO Nr.	DESCRIZIONE	DESCRIPTION	DESIGNATION	BEZEICHNUNG	DENOMINACION	NOTE NOTES NOTES MARKE NOTAS	Q.TA' CONF. Q.TY PACK. Q.TE EMB. M.GE PAK. C.AD PAQ.	
1	57110P160101	TELAIO	FRAME	CADRE	RAHMEN	CHASIS		1	
2	B0159100506H	VITE (M10X1.25X50)	SCREW (M10X1.25X50)	VIS (M10X1.25X50)	SCHRAUBE (M10X1.25X50)	TORNILLO (M10X1.25X50)		1	
3	B0417101254H	DADO (M10)	NUT (M10)	ECROU (M10)	MUTTER (M10)	TUERCA (M10)		1	
4	B01591007562	VITE (M10X75)	SCREW (M10X75)	VIS (M10X75)	SHARAUBE (M10X75)	TORNILLO (M10X75)		1	
5	A303896076000	KIT PROTEZIONE MOTORE	KIT ENGINE PROTECTION	KIT PROTECTION MOTEUR	KIT SCHUTZ MOTOR	KIT PROTECCIÓN MOTOR		1	
6	52018J800000	VITE (M8X25)	SCREW (M8X25)	VIS (M8X25)	SHARAUBE (M8X25)	TORNILLO (M8X25)		1	
7	B0205080606H	VITE (M8X60)	SCREW (M8X60)	VIS (M8X60)	SHARAUBE (M8X60)	TORNILLO (M8X60)		1	
8	B0159101306H	VITE (M10X130)	SCREW (M10X130)	VIS (M10X130)	SCHRAUBE (M10X130)	TORNILLO (M10X130)		1	
9	57060P130000	BOCCOLA IN GOMMA	RUBBER BUSHING	DOUILLE EN CAOUTCHOUC	GUMMITÜLLE	CASQUILLO DE GOMA		1	
10	57028P160000	DISTANZIALE	SPACER	ENTRETOISE	DISTANZSTÜCK	DISTANCIAL		1	
11	57029P160000	DISTANZIALE	SPACER	ENTRETOISE	DISTANZSTÜCK	DISTANCIAL		1	
12	B01591012565	VITE	SCREW	VIS	SCHRAUBE	TORNILLO		1	
13	B0417060004H	DADO (M6)	NUT (M6)	ECROU (M6)	MUTTER (M6)	TUERCA (M6)		1	
14	B0159100686H	VITE	SCREW	VIS	SCHRAUBE	TORNILLO		1	
15	B0109060166H	VITE (M6X16)	SCREW (M6X16)	VIS (M6X16)	SHARAUBE (M6X16)	TORNILLO (M6X16)		1	
16	08100P160000	PIASTRINO	PLATE	PLAQUETTE	PLÄTTCHEN	LÁMINA		1	
17	57041P160000	STAFFA SINISTRA	L.H. BRACKET	BRIDE GAUCHE	LINKER BÜGEL	SOPORTE IZQUERDA		1	
18	57042P160000	STAFFA DESTRA	R.H. BRACKET	BRIDE DROITE	RECHTER BÜGEL	SOPORTE DERECHA		1	
19	57001P160000	PIASTRINO OMOLOGAZIONE	PLATE HOMOLOGATION	PLAQUETTE HOMOLOGATION	PLÄTTCHEN RATIFIKATION	LÁMINA HOMOLOGACION		1	
20	R170052095000	RIVETTO (3.2X7)	RIVET (3.2X7)	RIVET (3.2X7)	REIBNIETE (3.2X7)	REMACHE (3.2X7)		1	
21	43504E070001	TAMPONE IN GOMMA	RUBBER PAD	TAMPON EN CAOUTCHOUC	GUMMISTOPFEN	APOYO DE GOMA		1	
22	59400P160000	TELAIO ANTERIORE	FRONT FRAME	CADRE AVANT	VORAHMEN FRONTSEITE	CHASIS DELANTERO		1	
23	658035010010	CLIP FISSAGGIO RAPIDO (M6)	QUIK FASTENING (M6)	FIXATION RAPIDE (M6)	SCHNELLEBEFESTIGUNG (M6)	FIJACIÓN RÁPIDA (M6)		1	
24	R90751421B	VITE (TCEI M8X16)	SCREW (TCEI M8X16)	VIS (TCEI M8X16)	SHARAUBE (TCEI M8X16)	TORNILLO (TCEI M8X16)		5	

POS. NO. N. INDEX POS.	N. CODICE CODE NO. Nr. CODE ATRIBEL Nr. CODICO Nr.	DESCRIZIONE	DESCRIPTION	DESIGNATION	BEZEICHNUNG	DENOMINACION	NOTE NOTES NOTES MARKE NOTAS	Q.TA' CONF. Q.TY PACK. Q.TE EMB. M.GE PAK. C.AD PAQ.	
25	57480P160000	STAFFA	BRACKET	BRIDE	BÜGEL	SOPORTE		1	
26	B01591002065	VITE (M10X20)	SCREW (M10X20)	VIS (M10X20)	SHARAUBE (M10X20)	TORNILLO (M10X20)		1	
27	59460P160000	SUPPORTO CUPOLINO	HEADLIGHT FAIRING HOLDER	SUPPORT CARÉNAGE	HALTERUNG FAHRTWINDSCHUTZ	SOPORTE CÚPULA		1	
28	B0417100004H	DADO (M10)	NUT (M10)	ECROU (M10)	MUTTER (M10)	TUERCA (M10)		2	
29	B07000000802	RONDELLA ELASTICA	ELASTIC WASHER	RONDELLE ELASTIQUE	ELASTISCHER RING	ARANDELA ELÁSTICA		1	
30	B0109080166H	VITE (M8X16)	SCREW (M8X16)	VIS (M8X16)	SCHRAUBE (M8X16)	TORNILLO (M8X16)		1	
31	B01090601264	VITE (M6X12)	SCREW (M6X12)	VIS (M6X12)	SHARAUBE (M6X12)	TORNILLO (M6X12)		1	
32	B07030000802	RONDELLA	WASHER	RONDELLE	UNTERLEGSCHIEBE	ARANDELA		1	
33	08014P160000	VITE (M10X17)	SCREW (M10X17)	VIS (M10X17)	SCHRAUBE (M10X17)	TORNILLO (M10X17)		1	
34	65697P160000	COPERCHIO TELAIO SX	L.H. FRAME COVER	COUVERCLE CADRE GAUCHE	DECKEL RAHMENLINKER	TAPA CHASIS IZQUIERDA		1	
35	65698P160000	COPERCHIO TELAIO DX	R.H. FRAME COVER	COUVERCLE CADRE DROITE	DECKEL RAHMENRECHTES	TAPA CHASIS DERECHA		1	
36	B02830601262	VITE (M6X12)	SCREW (M6X12)	VIS (M6X12)	SHARAUBE (M6X12)	TORNILLO (M6X12)		1	
37	R320052144000	VITE (M6X35)	SCREW (M6X35)	VIS (M6X35)	SHARAUBE (M6X35)	TORNILLO (M6X35)		1	



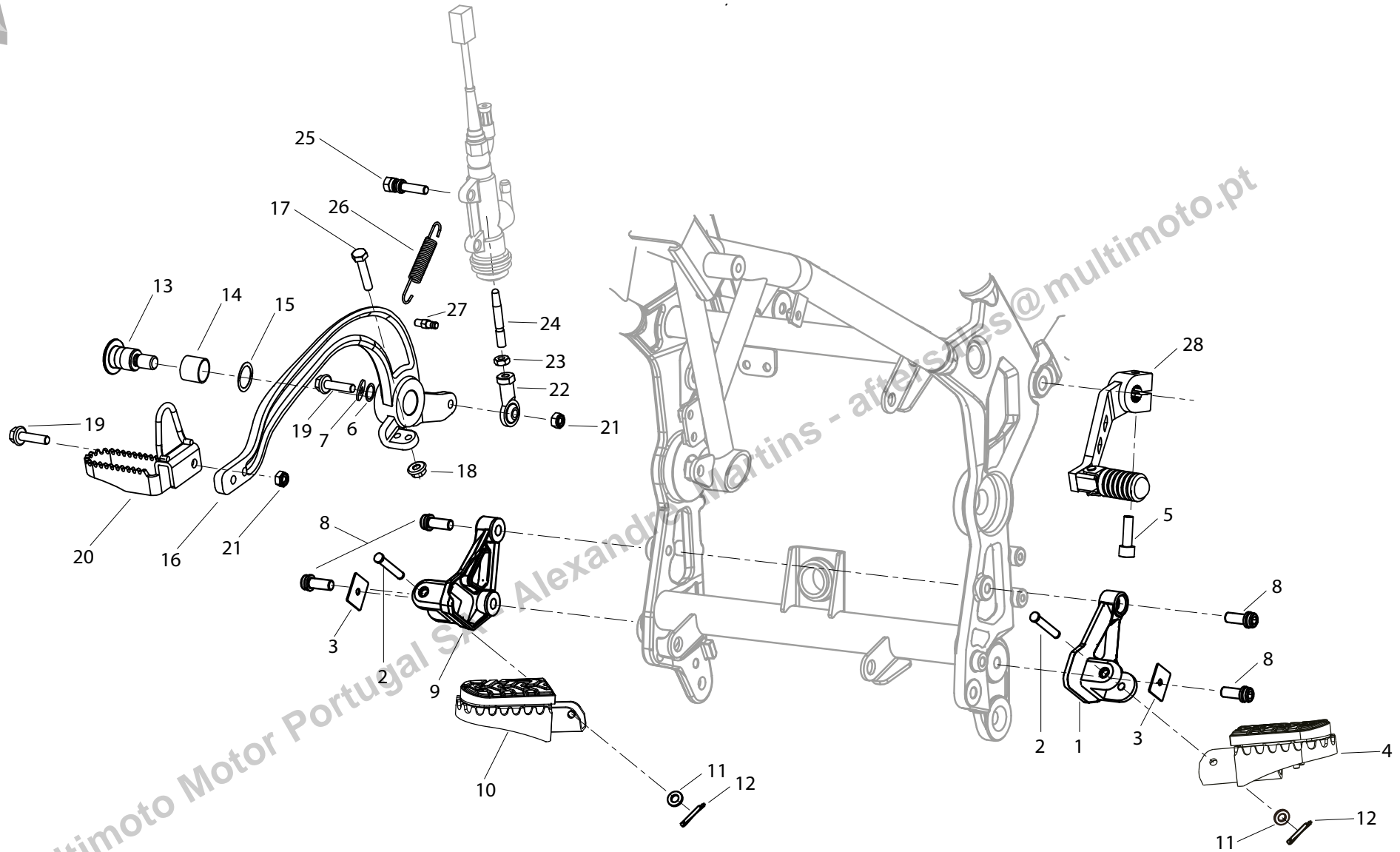

POS. NO. N. INDEX POS.	N. CODICE CODE NO. Nr. CODE ATRIKEL Nr. CODICO Nr.	DESCRIZIONE	DESCRIPTION	DESIGNATION	BEZEICHNUNG	DENOMINACION	NOTE NOTES NOTES MARKE NOTAS	Q.TA' CONF. Q.TY PACK. Q.TE EMB. M.GE PAK. C.AD PAQ.	
1	58226P160000	SUPPORTO PEDANA ANTERIORE SINISTRA	REAR L.H. FOOT PEG HOLDER	SUPPORT REPOSE-PIED AR. GAUCHE	HALTERUNG HINTERE FUSSRASTE LINKS	SOPORTE ESTRIBERA TRASERA IZQ.		1	
2	58217P260000	PERNO	PIN	PIVOT	ZAPFEN	PERNO		1	
3	58256P160000	PIASTRINO	PLATE	PLAQUETTE	PLÄTTCHEN	LÁMINA		1	
4	58220P160002	PEDANA ANTERIORE SINISTRA	L.H. FRONT FOOT PEG	REPOSE-PIED AVANT GAUCHE	VORDERE LINKFUSSRASTE	ESTRIBERA DELANTERA IZQ.		1	
5	B02810602062	VITE (M6X20)	SCREW (M6X20)	VIS (M6X20)	SHARAUBE (M6X20)	TORNILLO (M6X20)		1	
6	R21215391A	RONDELLA ELASTICA	ELASTIC WASHER	RONDELLE ELASTIQUE	ELASTISCHER RING	ARANDELA ELÁSTICA		1	
7	B0702000060H	RONDELLA	WASHER	RONDELLE	UNTERLEGSCHIEBE	ARANDELA		1	
8	B02810802062	VITE (M8X1.25X20)	SCREW (M8X1.25X20)	VIS (M8X1.25X20)	SHARAUBE (M8X1.25X20)	TORNILLO (M8X1.25X20)		5	
9	58246P160000	SUPPORTO PEDANA ANTERIORE DESTRA	REAR R.H. FOOT PEG HOLDER	SUPPORT REPOSE-PIED AR. DROITE	HALTERUNG HINTERE FUSSRASTE RECHTS	SOPORTE ESTRIBERA TRASERA DER.		1	
10	58240P160002	PEDANA ANTERIORE DESTRA	R.H. FRONT FOOT PEG	REPOSE-PIED AVANT DROIT	VORDERE RECHTE FUSSRASTE	ESTRIBERA DELANTERA DER.		1	
11	B0703000060A	RONDELLA	WASHER	RONDELLE	UNTERLEGSCHIEBE	ARANDELA		1	
12	B090002018AH	COPIGLIA	SPLIT PIN	GOUIPILLE	SPLINT	CLAVIJA		1	
13	R320052289000	VITE	SCREW	VIS	SCHRAUBE	TORNILLO		1	
14	58511S010000	BOCCOLA	BUSH	DOUILLE	BUCHSE	CASQUILLO		1	
15	R21215391A	RONDELLA ELASTICA	ELASTIC WASHER	RONDELLE ELASTIQUE	ELASTISCHER RING	ARANDELA ELÁSTICA		1	
16	58471P160000	PEDALE COMANDO FRENO	BRAKE CONTROL PEDAL	PÉDALE DE COMMANDE FREIN	FUSSBREMSPEDAL	PEDAL MANDO FRENO		1	
17	B01010603522	VITE (M6X35)	SCREW (M6X35)	VIS (M6X35)	SCHRAUBE (M6X35)	TORNILLO (M6X35)		1	
18	B0407060005H	DADO (M6)	NUT (M6)	ECROU (M6)	MUTTER (M6)	TUERCA (M6)		1	
19	160106030130	VITE (M6X30)	SCREW (M6X30)	VIS (M6X30)	SHARAUBE (M6X30)	TORNILLO (M6X30)		1	
20	40720V300100	PEDALE COMANDO FRENO	BRAKE CONTROL PEDAL	PÉDALE DE COMMANDE FREIN	FUSSBREMSPEDAL	PEDAL MANDO FRENO		1	
21	R91750031B	DADO (M6)	NUT (M6)	ECROU (M6)	MUTTER (M6)	TUERCA (M6)		10	
22	R21813851A	SNODO SFERICO	BALL JOINT	JOINT À ROTULE	KUGELGELENK	ARTICULACIÓN ESFERI		1	
23	R91551041B	DADO (M6)	NUT (M6)	ECROU (M6)	MUTTER (M6)	TUERCA (M6)		10	
24	55061P120000	ASTA DI REGISTRO	ADJUSTER ROD	TIGE DE RÉGLAGE	EINSTELLSTAB	VORILLA DE REGULACIÓN		1	

 **PEDANE ANTERIORI**

 **FRONT FOOT PEG**

 **REPOSE PIED AVANT**

 **VORDERE FUSSRASTE**

 **ESTRIBERAS DELANTERA**

TAVOLA
DRAWING
TABLE
BILD
TABLA

POS. NO. N. INDEX POS.	N. CODICE CODE NO. Nr. CODE ATRIKEL Nr. CODICO Nr.	DESCRIZIONE	DESCRIPTION	DESIGNATION	BEZEICHNUNG	DENOMINACION	NOTE NOTES NOTES MARKE NOTAS	Q.TA' CONF. Q.TY PACK. Q.TE EMB. M.GE PAK. C.AD PAQ.	
25	08013P160000	VITE (M6X22)	SCREW (M6X22)	VIS (M6X22)	SCHRAUBE (M6X22)	TORNILLO (M6X22)		1	
26	40702P160000	MOLLA RITORNO	RETURN SPRING	RESSORT DE RETOUR	RÜCKSCHLAGFEDER	MUELLE DE RETORNO		1	
27	40273P250000	PERNO FILETTATO	THREADED PIN	PIVOT FILETÉE	GEWINDEZAPFEN	PERNO FILETEADO		1	
28	08370P160000	PEDALE COMANDO CAMBIO	GEARCHANGE PEDAL	PÉDALE DE COMMANDE VITESSES	GANGSCHALTPEDAL	PEDAL MANDO CAMBIO		1	



Multimoto Motor Portugal SA - Alexandre Martins - aftersales@multimoto.pt

 **PEDANE POSTERIORI**

 **REAR FOOT PEG**

 **REPOSE PIED ARIERE**

 **HINTERE FUSSRASTE**

 **ESTRIBERAS TRASERA**

TAVOLA
DRAWING
TABLE
BILD
TABLA

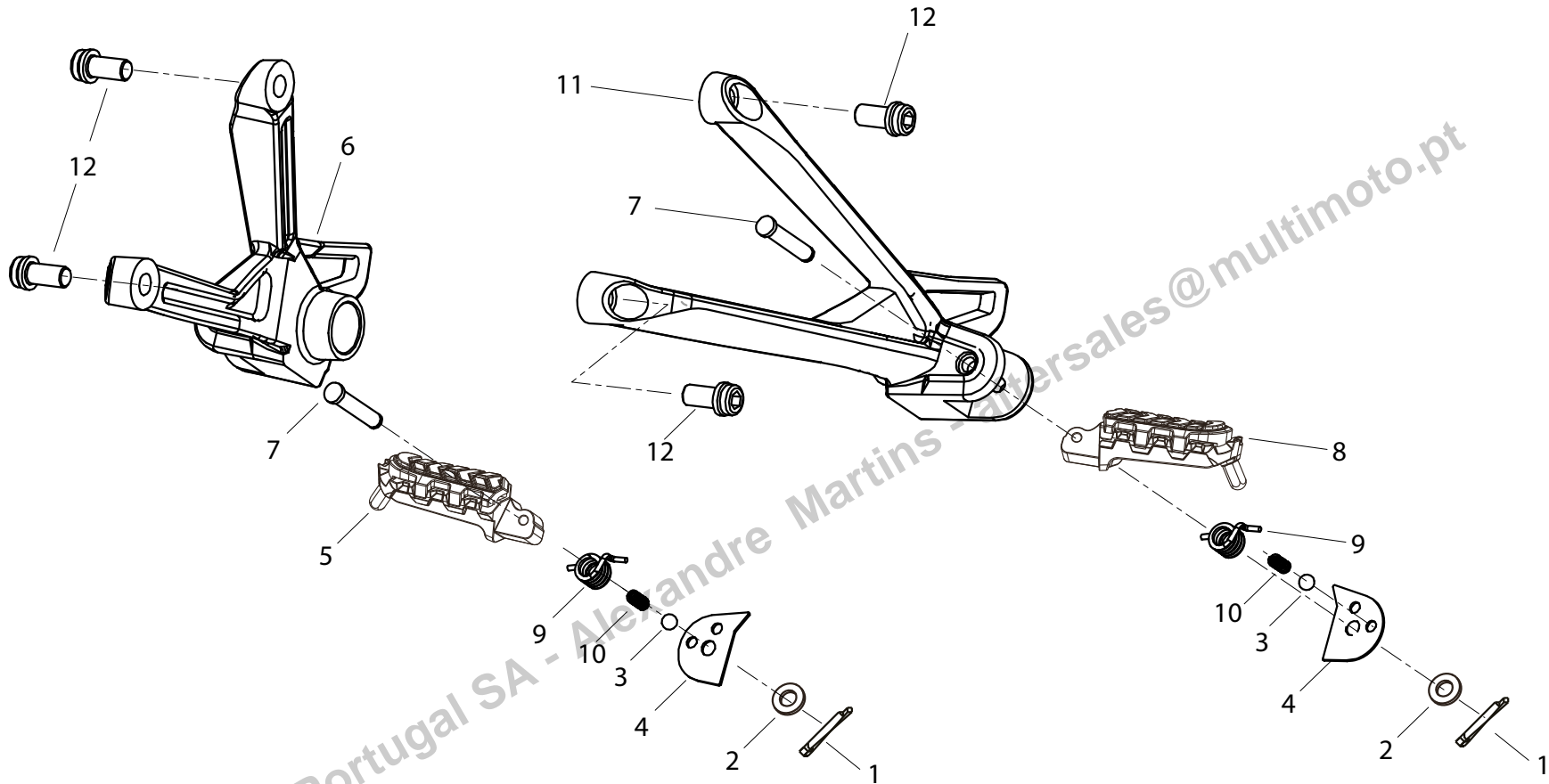

 **PEDANE POSTERIORI**

 **REAR FOOT PEG**

 **REPOSE PIED ARIERRE**

 **HINTERE FUSSRASTE**

 **ESTRIBERAS TRASERA**

TAVOLA
DRAWING
TABLE
BILD
TABLA

POS. NO. N. INDEX POS.	N. CODICE CODE NO. Nr. CODE ATRIKEL Nr. CODICO Nr.	DESCRIZIONE	DESCRIPTION	DESIGNATION	BEZEICHNUNG	DENOMINACION	NOTE NOTES NOTES MARKE NOTAS	Q.TA' CONF. Q.TY PACK. Q.TE EMB. M.GE PAK. C.AD PAQ.	
1	B090002018AH	COPIGLIA	SPLIT PIN	GOUPILLE	SPLINT	CLAVIJA		1	
2	B0703000060A	RONDELLA	WASHER	RONDELLE	UNTERLEGSSCHEIBE	ARANDELA		1	
3	B06000002000	SFERA	BALL	BILLE	KUGEL	ESFERA		1	
4	58451S010000	PIASTRINO	PLATE	PLAQUETTE	PLÄTTCHEN	LÁMINA		1	
5	58280P160000	PEDANA POSTERIORE DESTRA	R.H. REAR FOOT PEG	REPOSE-PIED AR. DROITE	HINTERE FUSSRASTE RECHTS	ESTRIBERA TRASERA DER.		1	
6	58471P160000	SUPPORTO PEDANA POSTERIORE DESTRA	REAR R.H. FOOT PEG HOLDER	SUPPORT REPOSE-PIED AR. DROITE	HALTERUNG HINTERE FUSSRASTE RECHTS	SOPORTE ESTRIBERA TRASERA DER.		1	
7	58217P100000	PERNO	PIN	PIVOT	ZAPFEN	PERNO		1	
8	58260P160000	PEDANA POSTERIORE SINISTRA	L.H. REAR FOOT PEG	REPOSE-PIED AR. GAUCHE	HINTERE FUSSRASTE LINKS	ESTRIBERA TRASERA IZQ.		1	
9	58202D010100	MOLLA	SPRING	RESSORT	FEDER	MUELLE		1	
10	58222B930000	MOLLA	SPRING	RESSORT	FEDER	MUELLE		1	
11	58451P160000	SUPPORTO PEDANA POSTERIORE SINISTRA	REAR L.H. FOOT PEG HOLDER	SUPPORT REPOSE-PIED AR. GAUCHE	HALTERUNG HINTERE FUSSRASTE LINKS	SOPORTE ESTRIBERA TRASERA IZQ.		1	
12	R90751451B	VITE (TCEI M8X25)	SCREW (TCEI M8X25)	VIS (TCEI M8X25)	SHARAUBE (TCEI M8X25)	TORNILLO (TCEI M8X25)		5	



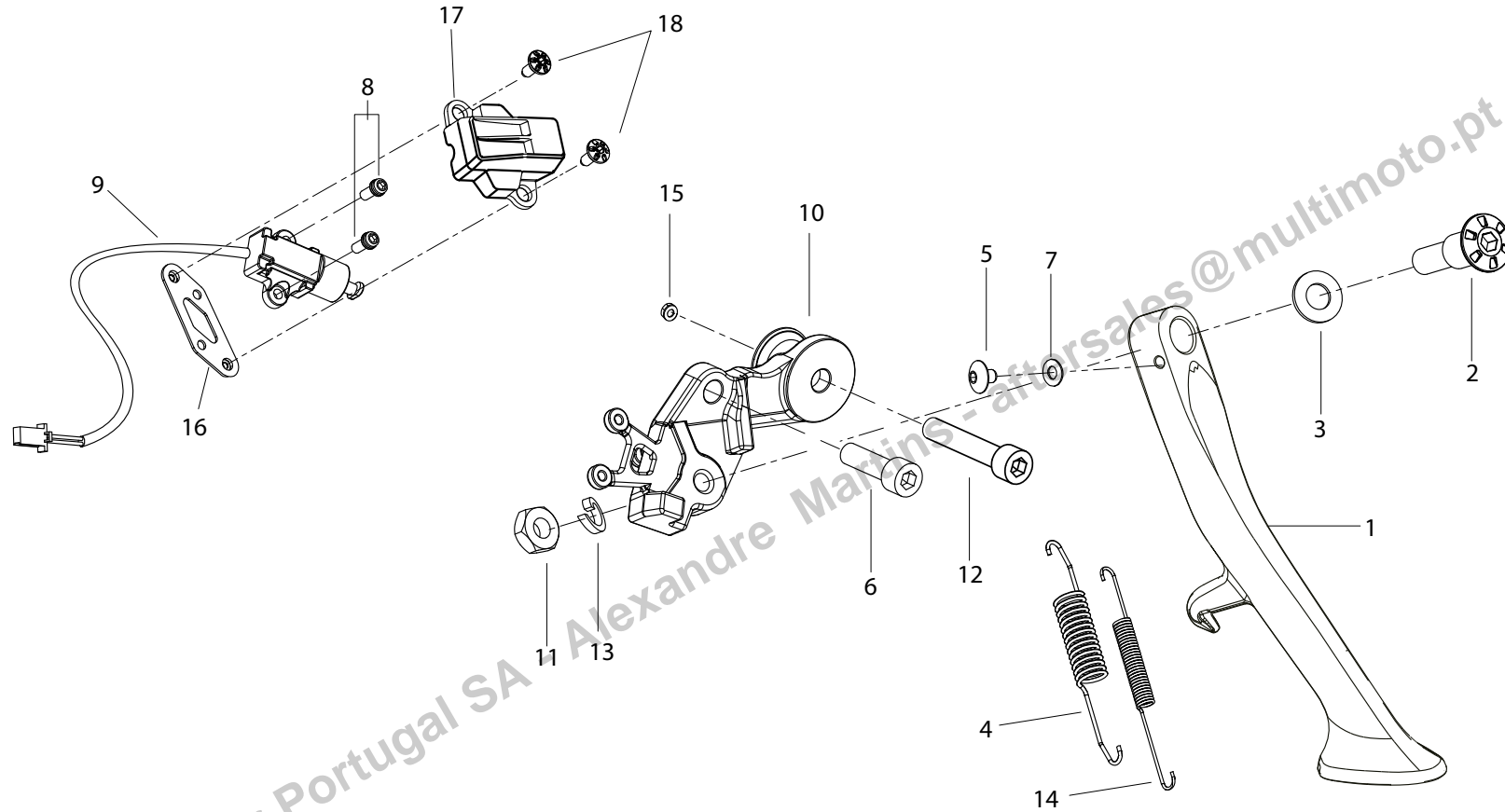

POS. NO. N. INDEX POS.	N. CODICE CODE NO. Nr. CODE ATRIBEL Nr. CODICO Nr.	DESCRIZIONE	DESCRIPTION	DESIGNATION	BEZEICHNUNG	DENOMINACION	NOTE NOTES NOTES MARKE NOTAS	Q.TA' CONF. Q.TY PACK. Q.TE EMB. M.GE PAK. C.AD PAQ.	
1	58701P160001	CAVALLETTO LATERALE	SIDE STAND	BÉQUILLE LATERALE	SEITENSTÄNDER	CABALLETE LATERAL		1	
2	57005P280000	VITE CAVALLETTO LATERALE	SCREW SIDE STAND	VIS BÉQUILLE LATERALE	SCHRAUBE SEITENSTÄNDER	TORNILLO CABALLETE LATERAL		1	
3	08021P250000	ROSETTA	WASHER	ROSETTE	UNTERLEGSCHLEIBE	ARANDELA		1	
4	57003P160000	MOLLA ESTERNA	OUTER SPRING	RESSORT EXTERNE	ÄUßERE FEDER	MUELLE EXTERIOR		1	
5	R320052046000	VITE (M6X8)	SCREW (M6X8)	VIS (M6X8)	SHARAUBE (M6X8)	TORNILLO (M6X8)		1	
6	B0205100406H	VITE (M10X40)	SCREW (M10X40)	VIS (M10X40)	SCHRAUBE (M10X40)	TORNILLO (M10X40)		1	
7	B0703000060H	RONDELLA	WASHER	RONDELLE	UNTERLEGSCHLEIBE	ARANDELA		1	
8	B02810501662	VITE (M5X16)	SCREW (M5X16)	VIS (M5X16)	SCHRAUBE (M5X16)	TORNILLO (M5X16)		5	
9	91170P160000	INTERRUTTORE CAVALLETTO LATERALE	SWITCH, SIDE STAND WARNING	INTERRUPTEUR BEQUILLE LATERAL	SEITENSTAENDERSCHALTER	INTERRUPTOR CABALLETE LATERAL		1	
10	57405P280000	PIASTRA SUPPORTO CAVALLETTO LATERALE	SIDE STAND SUPPORT PLATE	PLAQUE DE SUPPORT BÉQUILLE LATERALE	HALTEPLATTE FÜR SEITENSTÄNDER	PLACA DE SOPORTE CABALLETE LATERAL		1	
11	B04031212514	DADO (M12X1.25)	NUT (M12X1.25)	ECROU (M12X1.25)	MUTTER (M12X1.25)	TUERCA (M12X1.25)		1	
12	B0205100606H	VITE (M10X60)	SCREW (M10X60)	VIS (M10X60)	SHARAUBE (M10X60)	TORNILLO (M10X60)		1	
13	B07000001204	MOLLA A TAZZA	SPRING WASHER	BELLEVILLE	TELLERFEDER	ARANDELA DE MUELLE		1	
14	57004P160000	MOLLA INTERNA	INNER SPRING	RESSORT INTERNE	INNERE FEDER	MUELLE INTERIOR		1	
15	B0417100004H	DADO (M10)	NUT (M10)	ECROU (M10)	MUTTER (M10)	TUERCA (M10)		1	
16	58730P290000	PIASTRINO	PLATE	PLAQUETTE	PLÄTTCHEN	LÁMINA		1	
17	91171P290000	COPERCHIO	COVER	COUVERCLE	DECKEL	TAPA		1	
18	R90752268E	VITE (M6X15.2)	SCREW (M6X15.2)	VIS (M6X15.2)	SHARAUBE (M6X15.2)	TORNILLO (M6X15.2)		1	

 **MANUBRI E
COMANDI**

 **HANDLEBAR
AND CONTROLS**

 **GUIDON ET
COMANDES**

 **LENKER UND
STEUERORGANE**

 **MANILLARY
MANDOS**

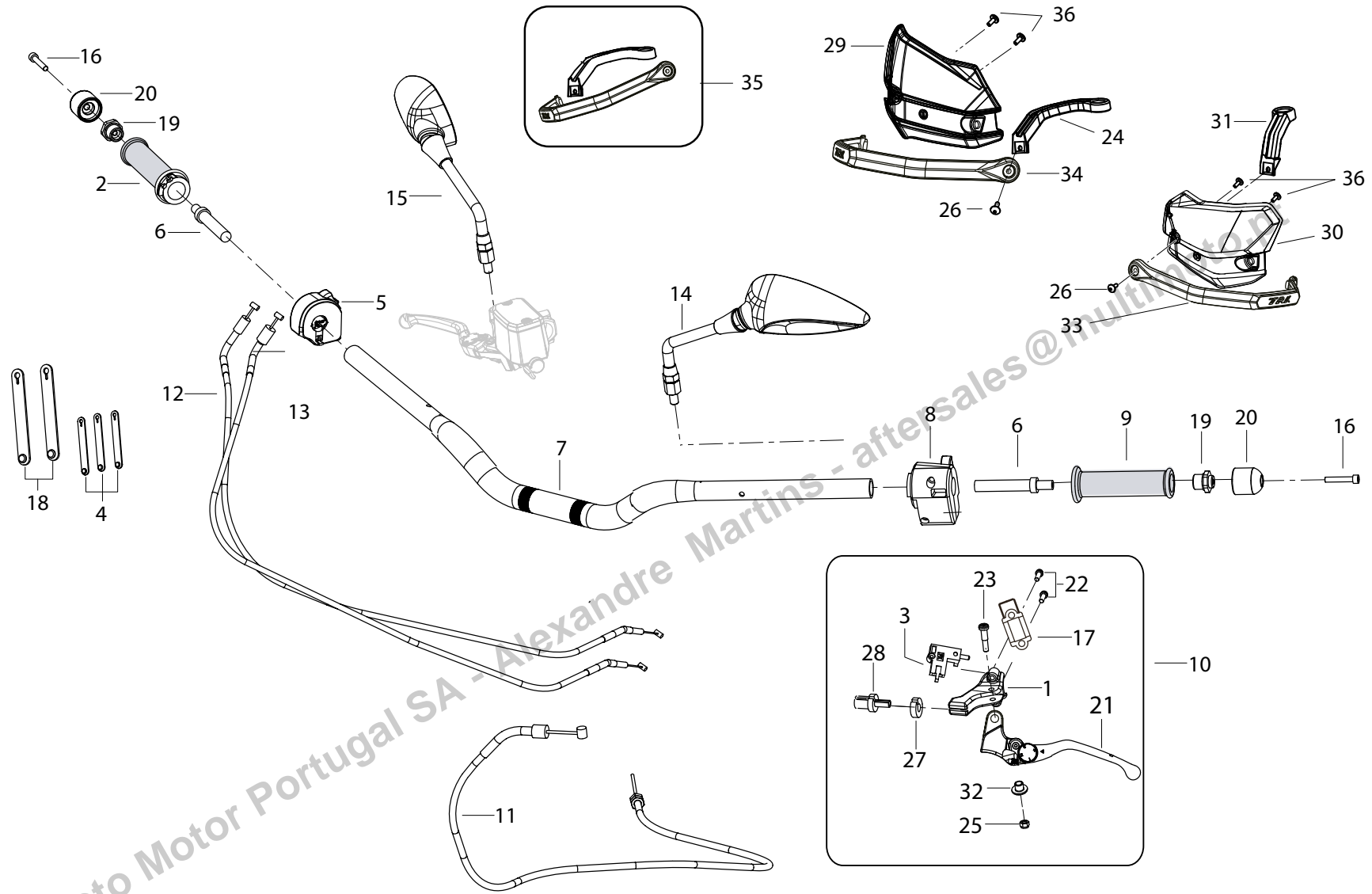

POS. NO. N. INDEX POS.	N. CODICE CODE NO. Nr. CODE ATRIBEL Nr. CODICO Nr.	DESCRIZIONE	DESCRIPTION	DESIGNATION	BEZEICHNUNG	DENOMINACION	NOTE NOTES NOTES MARKE NOTAS	Q.TA' CONF. Q.TY PACK. Q.TE EMB. M.GE PAK. C.AD PAQ.	
1	40081P250001	SUPPORTO LEVA	LEVER HOLDER	SUPPORT LEVIER	HALTERUNGSHEBEL	SOPORTE LEVA		1	
2	40210P160000	MANOPOLA DESTRA	R.H.GRIP	POIGNÉE DROITE	DREHKNOFF RECHTES	PUÑO DERECHA		1	
3	91090P250000	INTERRUPTORE FRIZIONE	CLUTCH SWITCH	INTERRUPTEUR EMBRAYAGE	KUPPLUNGSSCHALTER	INTERRUPTOR EMBRAGUE		1	
4	49371T620000	GUIDA TUBO	TUBE GUIDE	GUIDE DE TUBE	LEITUNG-FÜHRER	GUÍA DEL TUBO		1	
5	40600P370004	COMMUTATORE LUCI DESTRO	R.H. LIGHTS SWITCH	COMMUTEUR FEUX DROIT	RECHTES LENKERSCHALTER	CONMUTADOR LUCES DERECHO		1	
6	40031S010000	TERMINALE MANOPOLA	HAND GRIP TERMINAL	TERMINAISON POIGNÉE	ENDSTÜCK GRIFF	TERMINAL PUÑO		1	
7	40101P260002	MANUBRIO (NERO)	HANDLEBAR (BLACK)	GUIDON (NOIR)	LENKER (SCHWARZ)	MANILLAR (NEGRO)		1	
8	40500P370002	COMMUTATORE LUCI SINISTRO	L.H. LIGHTS SWITCH	COMMUTEUR FEUX GAUCHE	LINKS LENKERSCHALTER	CONMUTADOR LUCES IZQUIERDO		1	
9	40001P160000	MANOPOLA SINISTRA	L.H. GRIP	POIGNÉE GAUCHE	DREHKNOFF LINKS	PUÑO IZQUERDA		1	
10	40080P160101	COMANDO FRIZIONE COMPLETO	COMPLET CLUTCH CONTROL	COMMANDE EMBRAYAGE COMPLET	KOMPLETT KUPPLUNGSSTEUERUNG	ACCINAMENTO EMBRAGUE COMPLETO		1	
11	40400P160002	CAVO FRIZIONE	CLUTCH CABLE	CÂBLE EMBRAYAGE	KUPPLUNG KABEL	CABLE EMBRAGUE		1	
12	40300P160003	CAVO APERTURA GAS	CABLE OPENING THROTTLE	CÂBLE OVERTURE GAZ	GASÖFFNUNGSKABEL	CABLE ABERTURA ACELERADOR		1	
13	40330P160003	CAVO CHIUSURA GAS	CABLE CLOSING THROTTLE	CÂBLE FERMETURE GAZ	GASCHLIEßKABEL	CABLE CIERRE ACELERADOR		1	
14	40450P160000	SPECCHIO RETROVISORE SINISTRO	L.H. REAR-VIEW MIRROR	RÉTROVISEUR GAUCHE	LINKS RÜCKSPIEGEL	ESPEJO RETROVISOR IZQUIERDA		1	
15	40480P160000	SPECCHIO RETROVISORE DESTRO	R.H. REAR-VIEW MIRROR	RÉTROVISEUR DROIT	RECHTER RÜCKSPIEGEL	ESPEJO RETROVISOR DERECHA		1	
16	B0284060400A	VITE (M6X40)	SCREW (M6X40)	VIS (M6X40)	SCHRAUBE (M6X40)	TORNILLO (M6X40)		1	
17	40082P250000	CAVALLOTTO	BRACKET	CAVALIER	BÜGELBOLZEN	PERNO DE U		1	
18	40023P250000	FASCETTA IN GOMMA	RUBBER HOSE CLAMP	COLLIER EN CAOUTCHOUC	GUMMISCHELLE	ABRAZADERA EN GOMA		1	
19	40032P250000	TAPPO MANOPOLA	GRIP CAP	BOUCHON POIGNÉE	VERSCHLUß DREHKNOFF	TAPÓN DE PUÑO		1	
20	40031P160000	TERMINALE MANOPOLA	HAND GRIP TERMINAL	TERMINAISON POIGNÉE	ENDSTÜCK GRIFF	TERMINAL PUÑO		1	
21	41080P160101	LEVA COMANDO FRIZIONE	CLUTCH CONTROL LEVER	LEVIER DE COMMANDE EMBRAYAGE	KUPPLUNGHEBEL	LEVA MANDO EMBRAGUE		1	
22	B02810603062	VITE (M6X30)	SCREW (M6X30)	VIS (M6X30)	SHARAUBE (M6X30)	TORNILLO (M6X30)		1	
23	40083P250000	VITE	SCREW	VIS	SCHRAUBE	TORNILLO		1	

POS. NO. N. INDEX POS.	N. CODICE CODE NO. Nr. CODE ATRÍKEL Nr. CODICO Nr.	DESCRIZIONE	DESCRIPTION	DESIGNATION	BEZEICHNUNG	DENOMINACION	NOTE NOTES NOTES MARKE NOTAS	Q.TA' CONF. Q.TY PACK. Q.TY EMB. M.GE PAK. C.AD PAQ.	
24	65219P160003	STAFFA SUPPORTO DX	R.H. HOLDER BRACKET	BRIDE SUPPORT DROIT	BÜGEL HALTERUNG RECHTES	ESTRIBO SOPORTE DER.		1	
25	B04160600065	DADO (M6)	NUT (M6)	ECROU (M6)	MUTTER (M6)	TUERCA (M6)		1	
26	08012P160000	VITE (M5X16)	SCREW (M5X16)	VIS (M5X16)	SCHRAUBE (M5X16)	TORNILLO (M5X16)		1	
27	40087K010000	DADO SPECIALE	SPECIAL NUT	ECROU SPÉCIALE	SPEZIALMUTTER	TUERCA ESPECIAL		1	
28	40086K010000	VITE SPECIALE	SPECIAL SCREW	VIS SPÉCIALE	SPEZIALSCHRAUBE	TORNILLO ESPECIAL		1	
29	65217P160001	PARAMANO DX	R.H. HAND GUARD	PROTECTION-MAIN DROIT	HANDSCHUTZ RECHTES	PROTECCIÓN MANO DER.		1	
30	65216P160001	PARAMANO SX	L.H. HAND GUARD	PROTECTION-MAIN GAUCHE	HANDSCHUTZ LINKS	PROTECCIÓN MANO IZQ.		1	
31	65218P160002	STAFFA SUPPORTO SX	L.H. HOLDER BRACKET	BRIDE SUPPORT GAUCHE	BÜGEL HALTERUNG LINKS	ESTRIBO SOPORTE IZO.		1	
32	40085S010000	BOCCOLA	BUSH	DOUILLE	BUCHSE	CASQUILLO		1	
33	65221P160002	STAFFA PARAMANO SX	L.H. HAND GUARD BRACKET	BRIDE PROTECTION-MAIN GAUCHE	BÜGEL HANDSCHUTZ LINKS	SOPORTE PROTECCIÓN MANO IZQ.		1	
34	65222P160003	STAFFA PARAMANO DX	R.H. HAND GUARD BRACKET	BRIDE PROTECTION-MAIN DROIT	BÜGEL HANDSCHUTZ RECHTES	SOPORTE PROTECCIÓN MANO DER.		1	
35	65220P16003Z	KIT STAFFA SUPPORTO PARAMANI DESTRO	R.H. KIT HAND-GUARD BRACKET	KIT BRIDE SUPPORT PROTEGE-MAIN DROIT	KIT BÜGEL HALTERUNG HANDSCHUTZ RECHTES	KIT ESTRIBO SOPORTE GUARDAMANO DER.		1	
36	08011P160000	VITE (M5X12)	SCREW (M5X12)	VIS (M5X12)	SCHRAUBE (M5X12)	TORNILLO (M5X12)		1	

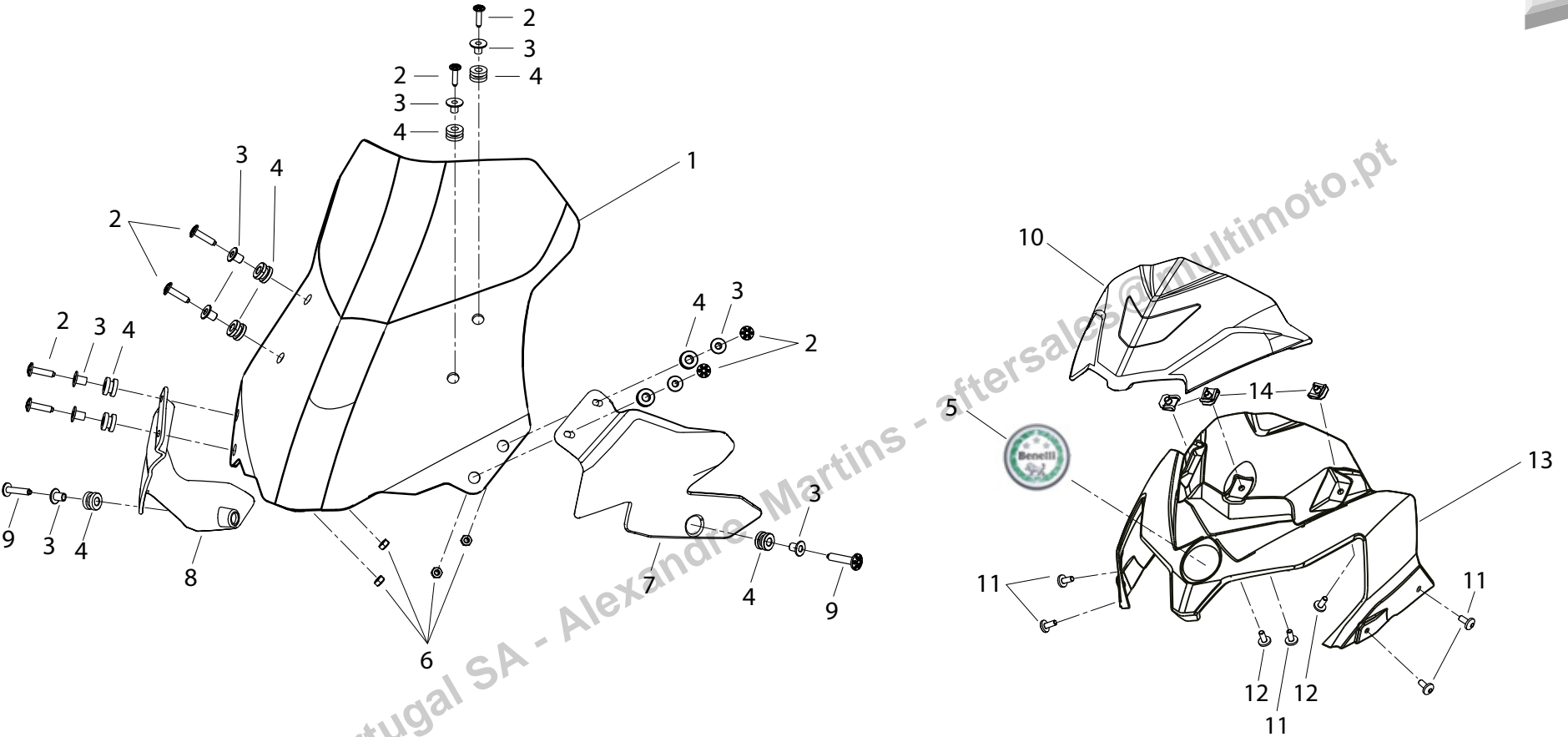

POS. NO. N. INDEX POS.	N. CODICE CODE NO. Nr. CODE ATRÍKEL Nr. CODICO Nr.	DESCRIZIONE	DESCRIPTION	DESIGNATION	BEZEICHNUNG	DENOMINACION	NOTE NOTES NOTES MARKE NOTAS	Q.TA' CONF. Q.TY PACK. Q.TE EMB. M.GE PAK. C.AD PAQ.	
1	65503P160000	CUPOLINO MOBILE	MOBILE HEADLIGHT FAIRING	BULLE MOBILE	BEWEGLICHECOCKPITVERKLEIDUNG	CÚPULA MÓVIL		1	
2	R320452063000	VITE (M6X25)	SCREW (M6X25)	VIS (M6X25)	SHARAUBE (M6X25)	TORNILLO (M6X25)		1	
3	65517K320000	DISTANZIALE	SPACER	ENTRETOISE	DISTANZSTÜCK	DISTANCIAL		1	
4	R300079190000	ANTIVIBRANTE	VIBRATION DAMPER	ANTIVIBRATION	SCHWINGUNGSDÄMPFER	ANTI-VIBRACIÓN		1	
5	05521B450000	ADESIVO	STICKER	DÉCALCOMANIE	AUFKLEBER	ADHESIVO		1	
6	R91750031B	DADO (M6)	NUT (M6)	ECROU (M6)	MUTTER (M6)	TUERCA (M6)		10	
7	65204P160000	CUPOLINO SINISTRO	L.H. HEADLIGHT FAIRING	CARÈNAGE GAUCHE	FAHRTWINDSCHUTZ LINKES	CÚPULA IZQUIERDA		1	
8	65205P160000	CUPOLINO DESTRO	R.H. HEADLIGHT FAIRING	CARÈNAGE DROITE	FAHRTWINDSCHUTZ RECHTER	CÚPULA DERECHA		1	
9	65624P160000	CLIP FISSAGGIO RAPIDO (M5)	QUICK FASTENING (M5)	FIXATION RAPIDE (M5)	SCHNELLEBEFESTIGUNG (M5)	FIJACIÓN RÁPIDA (M5)		1	
10	65203P160000	CUPOLINO	HEADLIGHT FAIRING	CARÈNAGE	FAHRTWINDSCHUTZ	CÚPULA		1	
11	08011P160000	VITE (M5X12)	SCREW (M5X12)	VIS (M5X12)	SCHRAUBE (M5X12)	TORNILLO (M5X12)		1	
12	08012P160000	VITE (M5X16)	SCREW (M5X16)	VIS (M5X16)	SCHRAUBE (M5X16)	TORNILLO (M5X16)		1	
13	65201P16WS00	CUPOLINO FISSO	FIXED HEADLIGHT FAIRING	BULLE FIXE	FESTSTEHENDECOCKPITVERKLEIDUNG	CÚPULA FIJA		1	
13	65201P16JS00	CUPOLINO FISSO	FIXED HEADLIGHT FAIRING	BULLE FIXE	FESTSTEHENDECOCKPITVERKLEIDUNG	CÚPULA FIJA		1	
13	65201P16FH00	CUPOLINO FISSO	FIXED HEADLIGHT FAIRING	BULLE FIXE	FESTSTEHENDECOCKPITVERKLEIDUNG	CÚPULA FIJA		1	
13	65201P16KD00	CUPOLINO FISSO	FIXED HEADLIGHT FAIRING	BULLE FIXE	FESTSTEHENDECOCKPITVERKLEIDUNG	CÚPULA FIJA		1	



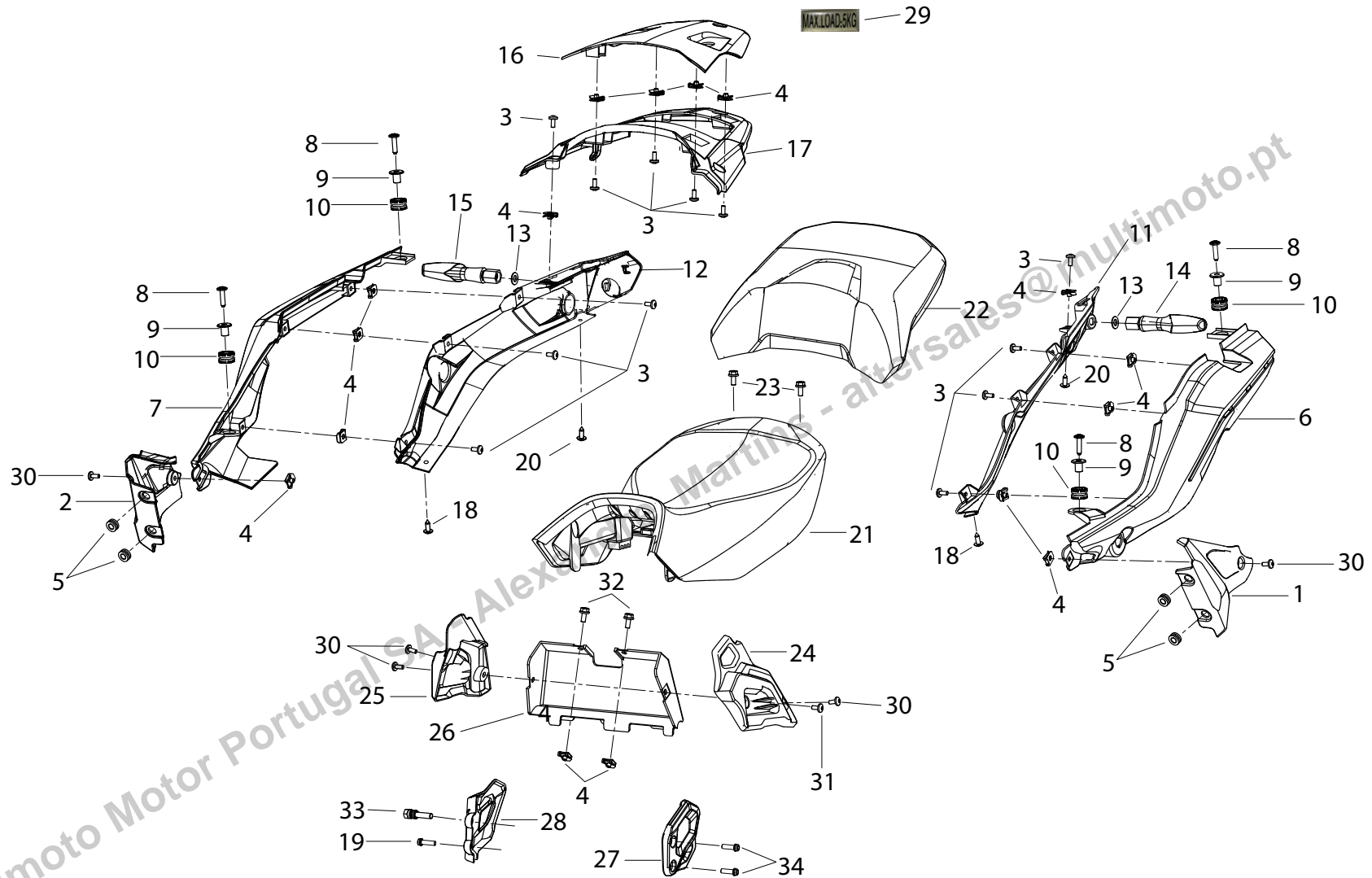

POS. NO. N. INDEX POS.	N. CODICE CODE NO. Nr. CODE ATRIKEL Nr. CODICO Nr.	DESCRIZIONE	DESCRIPTION	DESIGNATION	BEZEICHNUNG	DENOMINACION	NOTE NOTES NOTES MARKER NOTAS	Q.TA' CONF. Q.TY PACK. Q.TE EMB. M.GE PAK. C.AD PAK.	
1	65601P160000	PANNELLO SINISTRO	L.H. PANEL	PANNEAU GAUCHE	TAFEL LINKS	PANEL IZQUIERDA		1	
2	65602P160001	CHIUSURA CARENA	UPPER FAIRING	FERMETURE CARÈNE	VERSCHLUSS VERKLEIDUNG	CIERRE CARENADO		1	
3	08011P160000	VITE (M5X12)	SCREW (M5X12)	VIS (M5X12)	SCHRAUBE (M5X12)	TORNILLO (M5X12)		1	
4	65624P160000	CLIP FISSAGGIO RAPIDO (M5)	QUICK FASTENING (M5)	FIXATION RAPIDE (M5)	SCHNELLEBEFESTIGUNG (M5)	FIJACIÓN RÁPIDA (M5)		1	
5	43038P250000	GOMMINO ANTIVIBRANTE	VIBRATION DAMPER PAD	JOINT EN CAOUTCHOUC ANTI-VIBRATION	SCHWINGUNGSDÄMPFERGUMMI	JUNTA DE GOMA ANTI-VIBRACIÓN		1	
6	65901P16W500	FIANCHETTO POSTERIORE SINISTRO (BIANCO WS)	L.H. REAR BODY PANEL (WHITE WS)	PANNEAU LATÉRAL GAUCHE ARRIÈRE (BLANC WS)	LINK HINTERE SEITENABDECKUNG (WEISS WS)	PANEL LATERAL IZQUIERDO TRASERO (BLANCO WS)		1	
6	65901P16JS00	FIANCHETTO POSTERIORE SINISTRO (GRIGIO JS)	L.H. REAR BODY PANEL (GREY JS)	PANNEAU LATÉRAL GAUCHE ARRIÈRE (GRIS JS)	LINK HINTERE SEITENABDECKUNG (GRAU JS)	PANEL LATERAL IZQUIERDO TRASERO (GRIS JS)		1	
6	65901P16FH00	FIANCHETTO POSTERIORE SINISTRO (ROSSO FH)	L.H. REAR BODY PANEL (RED FH)	PANNEAU LATÉRAL GAUCHE ARRIÈRE (ROUGE FH)	LINK HINTERE SEITENABDECKUNG (ROT FH)	PANEL LATERAL IZQUIERDO TRASERO (ROJO FH)		1	
6	65901P16KD00	FIANCHETTO POSTERIORE SINISTRO (BLU KD)	L.H. REAR BODY PANEL (BLEU KD)	PANNEAU LATÉRAL GAUCHE ARRIÈRE (BLEU KD)	LINK HINTERE SEITENABDECKUNG (BLAU KD)	PANEL LATERAL IZQUIERDO TRASERO (AZUL KD)		1	
6	65901P16028Z	FIANCHETTO POSTERIORE SINISTRO (BIANCO WS) CON ADESIVI	L.H. REAR BODY PANEL (WHITE WS) WITH STICKERS	PANNEAU LAT. GAUCHE ARRIÈRE (BLANC WS) AVEC DÉCALCOMANIE	LINK HINTERE SEITENABDECKUNG (WEISS WS) MIT AUFKLEBER	PANEL LATERAL IZQUIERDO TRASERO (BLANCO WS) CON ADHESIVO		1	
6	65901P16029Z	FIANCHETTO POSTERIORE SINISTRO (GRIGIO JS) CON ADESIVI	L.H. REAR BODY PANEL (GREY JS) WITH STICKERS	PANNEAU LAT. GAUCHE ARRIÈRE (GRIS JS) AVEC DÉCALCOMANIE	LINK HINTERE SEITENABDECKUNG (GRAU JS) MIT AUFKLEBER	PANEL LATERAL IZQUIERDO TRASERO (GRIS JS) CON ADHESIVO		1	
6	65901P16030Z	FIANCHETTO POSTERIORE SINISTRO (ROSSO FH) CON ADESIVI	L.H. REAR BODY PANEL (RED FH) WITH STICKERS	PANNEAU LAT. GAUCHE ARRIÈRE (ROUGE FH) AVEC DÉCALCOMANIE	LINK HINTERE SEITENABDECKUNG (ROT FH) MIT AUFKLEBER	PANEL LATERAL IZQUIERDO TRASERO (ROJO FH) CON ADHESIVO		1	
6	65901P16031Z	FIANCHETTO POSTERIORE SINISTRO (BLU KD) CON ADESIVI	L.H. REAR BODY PANEL (BLEU KD) WITH STICKERS	PANNEAU LAT. GAUCHE ARRIÈRE (BLEU KD) AVEC DÉCALCOMANIE	LINK HINTERE SEITENABDECKUNG (BLAU KD) MIT AUFKLEBER	PANEL LATERAL IZQUIERDO TRASERO (AZUL KD) CON ADHESIVO		1	
7	65902P16W500	FIANCHETTO POSTERIORE DESTRO (BIANCO WS)	R.H. REAR BODY PANEL (WHITE WS)	PANNEAU LATÉRAL DROITE ARRIÈRE (BLANC WS)	RECHTS HINTERE SEITENABDECKUNG (WEISS WS)	PANEL LATERAL DERECHA TRASERO (BLANCO WS)		1	
7	65902P16JS00	FIANCHETTO POSTERIORE DESTRO (GRIGIO JS)	R.H. REAR BODY PANEL (GREY JS)	PANNEAU LATÉRAL DROITE ARRIÈRE (GRIS JS)	RECHTS HINTERE SEITENABDECKUNG (GRAU JS)	PANEL LATERAL DERECHA TRASERO (GRIS JS)		1	
7	65902P16FH00	FIANCHETTO POSTERIORE DESTRO (ROSSO FH)	R.H. REAR BODY PANEL (RED FH)	PANNEAU LATÉRAL DROITE ARRIÈRE (ROUGE FH)	RECHTS HINTERE SEITENABDECKUNG (ROT FH)	PANEL LATERAL DERECHA TRASERO (ROJO FH)		1	
7	65902P16KD00	FIANCHETTO POSTERIORE DESTRO (BLU KD)	R.H. REAR BODY PANEL (BLEU KD)	PANNEAU LATÉRAL DROITE ARRIÈRE (BLEU KD)	RECHTS HINTERE SEITENABDECKUNG (BLAU KD)	PANEL LATERAL DERECHA TRASERO (AZUL KD)		1	
7	65902P16028Z	FIANCHETTO POSTERIORE DESTRO (BIANCO WS) CON ADESIVI	R.H. REAR BODY PANEL (WHITE WS) WITH STICKERS	PANNEAU LAT. DROITE ARRIÈRE (BLANC WS) AVEC DÉCALCOMANIE	RECHTS HINTERE SEITENABDECKUNG (WEISS WS) MIT AUFKLEBER	PANEL LATERAL DERECHA TRASERO (BLANCO WS) CON ADHESIVO		1	
7	65902P16029Z	FIANCHETTO POSTERIORE DESTRO (GRIGIO JS) CON ADESIVI	R.H. REAR BODY PANEL (GREY JS) WITH STICKERS	PANNEAU LAT. DROITE ARRIÈRE (GRIS JS) AVEC DÉCALCOMANIE	RECHTS HINTERE SEITENABDECKUNG (GRAU JS) MIT AUFKLEBER	PANEL LATERAL DERECHA TRASERO (GRIS JS) CON ADHESIVO		1	
7	65902P16030Z	FIANCHETTO POSTERIORE DESTRO (ROSSO FH) CON ADESIVI	R.H. REAR BODY PANEL (RED FH) WITH STICKER	PANNEAU LAT. DROITE ARRIÈRE (ROUGE FH) AVEC DÉCALCOMANIE	RECHTS HINTERE SEITENABDECKUNG (ROT FH) MIT AUFKLEBER	PANEL LATERAL DERECHA TRASERO (ROJO FH) CON ADHESIVO		1	
7	65902P16031Z	FIANCHETTO POSTERIORE DESTRO (BLU KD) CON ADESIVI	R.H. REAR BODY PANEL (BLEU KD) WITH STICKERS	PANNEAU LAT. DROITE ARRIÈRE (BLEU KD) AVEC DÉCALCOMANIE	RECHTS HINTERE SEITENABDECKUNG (BLAU KD) MIT AUFKLEBER	PANEL LATERAL DERECHA TRASERO (AZUL KD) CON ADHESIVO		1	
8	R320452063000	VITE (M6X25)	SCREW (M6X25)	VIS (M6X25)	SHARAUBE (M6X25)	TORNILLO (M6X25)		1	
9	140035040010	BOCCOLA SUPERIORE	UPPER BUSH	DOUILLE SUPÉRIEURE	OBERER BUCHSE	CASQUILLO SUPERIOR		1	
10	R180479181000	GOMMINO	RUBBER PAD	JOINT EN CAOUTCHOUC	GUMMISTÜCK	JUNTA DE GOMA		1	

POS. NO. N. INDEX POS.	N. CODICE CODE NO. Nr. CODE ATRİKEL Nr. CODICO Nr.	DESCRIZIONE	DESCRIPTION	DESIGNATION	BEZEICHNUNG	DENOMINACION	NOTE NOTES NOTES MARKE NOTAS	Q.TA' CONF. Q.TY PACK. Q.TE EMB. M.GE PAK. C.AD PAQ.	
11	65911P160000	FIANCHETTO INFERIORE SINISTRO	L.H. LOWER BODY PANEL	PANNEAU INFÉRIEURE GAUCHE	LINK UNTERER SEITENABDECKUNG	PANEL INFERIOR IZQUIERDO		1	
12	65912P160000	FIANCHETTO INFERIORE DESTRO	R.H. LOWER BODY PANEL	PANNEAU INFÉRIEURE DROITE	RECHT UNTERER SEITENABDECKUNG	PANEL INFERIOR DERECHO		1	
13	08023P250000	RONDELLA	WASHER	RONDELLE	UNTERLEGSCHLEIBE	ARANDELA		1	
14	81500P160001	INDICATORE DI DIREZIONE COMPLETO (POSTERIORE) (SINISTRO)	COMPLETE TURN INDICATOR (REAR) (L.H.)	CLIGNOTANT COMPLÈTE (ARRIÈRE) (GAUCHE)	FAHRTRICHTUNGSANZEIGE KOMPLETT (HINTERERS) (LINK)	INDICADOR DE DIRECCIÓN COMPLETA (TRASERO) (IZQUIERDO)		1	
15	81700P160001	INDICATORE DI DIREZIONE COMPLETO (POSTERIORE) (DESTRO)	COMPLETE TURN INDICATOR (REAR) (R.H.)	CLIGNOTANT COMPLÈTE (ARRIÈRE) (DROIT)	FAHRTRICHTUNGSANZEIGE KOMPLETT (HINTERERS) (RECHT)	INDICADOR DE DIRECCIÓN COMPLETA (TRASERO) (DERECHO)		1	
16	65605P160010	COPERCHIO CENTRALE	COVER, CENTRAL	COUVERCLE CENTRAL	MITTLERER DECKEL	TAPA CENTRAL		1	
17	65606P160010	CARENATURA CENTRALE POSTERIORE	REAR CENTRAL FAIRING	CARÉNAGE CENTRAL ARRIÈRE	HINTERESHLE ZENTRALE	CARENADO CENTRAL TRASERO		1	
18	B05074201305	VITE (ST4.2X13)	SCREW (ST4.2X13)	VIS (ST4.2X13)	SHARAUBE (ST4.2X13)	TORNILLO (ST4.2X13)		10	
19	B02810602062	VITE (M6X20)	SCREW (M6X20)	VIS (M6X20)	SHARAUBE (M6X20)	TORNILLO (M6X20)		5	
20	B05074201015	VITE (ST4.2X10)	SCREW (ST4.2X10)	VIS (ST4.2X10)	SHARAUBE (ST4.2X10)	TORNILLO (ST4.2X10)		1	
21	51100P160102	SELLA	SEAT	SIEGE	SATTEL	SILLIN		1	
22	51200P160101	SELLA PASSEGGERO	PILLION REDER SEAT	SELLE PASSAGER	BEIFAHRERSITZ	SILLIN PASAJERO		1	
23	R700052157000	VITE (M6X16)	SCREW (M6X16)	VIS (M6X16)	SHARAUBE (M6X16)	TORNILLO (M6X16)		5	
24	65693P160000	PROTEZIONE SINISTRA	L.H. PROTECTION	PROTECTION GAUCHE	SCHUTZ LINKES	PROTECCIÓN IZQUIERDA		1	
25	65694P160000	PROTEZIONE DESTRA	R.H. PROTECTION	PROTECTION DROITE	SCHUTZ RECHTES	PROTECCIÓN DERECHO		1	
26	65695P160000	CHIUSURA CARENA	CLOSING FAIRING	FERMETURE CARÈNE	VERSCHLUSS VERKLEIDUNG	CIERRE CARENADO		1	
27	58211P160000	COPERCHIO TELAIO SX	L.H. FRAME COVER	COUVERCLE CADRE GAUCHE	DECKEL RAHMENLINKER	TAPA CHASIS IZQ.		1	
28	58311P160000	COPERCHIO TELAIO DX	R.H. FRAME COVER	COUVERCLE CADRE DROITE	DECKEL RAHMENRECHTES	TAPA CHASIS DERECHA		1	
29	R170093016000	ADESIVO	STICKER	DÉCALCOMANIE	AUFKLEBER	ADHESIVO		1	
30	08012P160000	VITE (M5X16)	SCREW (M5X16)	VIS (M5X16)	SCHRAUBE (M5X16)	TORNILLO (M5X16)		1	
31	R907520318	VITE (M6X14)	SCREW (M6X14)	VIS (M6X14)	SHARAUBE (M6X14)	TORNILLO (M6X14)		5	
32	B01090601262	VITE (M6X12)	SCREW (M6X12)	VIS (M6X12)	SHARAUBE (M6X12)	TORNILLO (M6X12)		1	
33	08013P160000	VITE (M6X22)	SCREW (M6X22)	VIS (M6X22)	SCHRAUBE (M6X22)	TORNILLO (M6X22)		1	
34	R320052145000	VITE (M6X12)	SCREW (M6X12)	VIS (M6X12)	SCHRAUBE (M6X12)	TORNILLO (M6X12)		1	

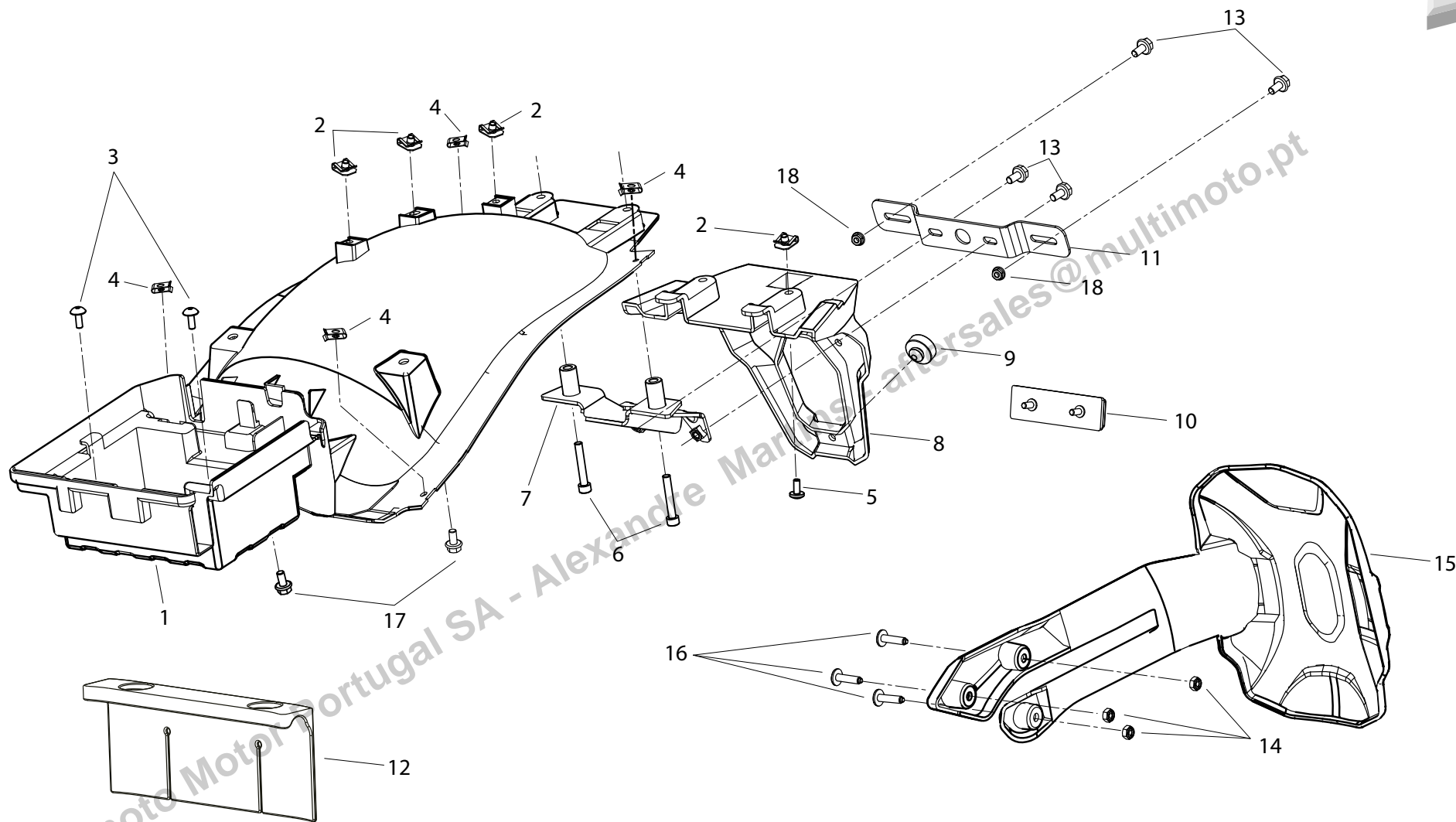

POS. NO. N. INDEX POS.	N. CODICE CODE NO. Nr. CODE ATRÍKEL Nr. CODICO Nr.	DESCRIZIONE	DESCRIPTION	DESIGNATION	BEZEICHNUNG	DENOMINACION	NOTE NOTES NOTES MARKE NOTAS	Q.TA' CONF. Q.TY PACK. Q.TE EMB. M.GE PAK. C.AD PAQ.	
1	65731P160000	CARENA SUPERIORE	UPPER FAIRING	CARÉNAGE SUPERIEURE	VERKLEIDUNGS OBERER	CARENADO SUPERIOR		1	
2	65624P160000	CLIP FISSAGGIO RAPIDO (M5)	QUIK FASTENING (M5)	FIXATION RAPIDE (M5)	SCHNELLEBEFESTIGUNG (M5)	EJACIÒN RÁPIDA (M5)		1	
3	R320052046000	VITE (M6X8)	SCREW (M6X8)	VIS (M6X8)	SHARAUBE (M6X8)	TORNILLO (M6X8)		1	
4	65801T020201	CLIP FISSAGGIO RAPIDO (ST4.2)	QUIK FASTENING (ST4.2)	FIXATION RAPIDE (ST4.2)	SCHNELLEBEFESTIGUNG (ST4.2)	EJACIÒN RÁPIDA (ST4.2)		1	
5	08011P160000	VITE (M5X12)	SCREW (M5X12)	VIS (M5X12)	SCHRAUBE (M5X12)	TORNILLO (M5X12)		1	
6	R320052064000	VITE (M6X40)	SCREW (M6X40)	VIS (M6X40)	SHARAUBE (M6X40)	TORNILLO (M6X40)		1	
7	65770P160000	PIASTRA	PLATE	PLAQUE	PLATTE	SOPORTE		1	
8	65701P160000	SUPPORTO PORTATARGA	NUMBER PLATE HOLDER	SUPPORT PORTE-PLAQUE	HALTERUNG NUMMERSCHILDTAFEL	SOPORTE PORTA-MATRÍCULA		1	
9	51103V030000	GOMMINO ANTIVIBRANTE	VIBRATION DAMPER PAD	JOINT EN CAOUTCHOUC ANTI-VIBRATION	SCHWINGUNGSDÄMPFERGUMMI	JUNTA DE GOMA ANTI-VIBRACIÒN		1	
10	86500B720001	CATADIOTTRO	REFLECTOR	CATADIOPTRE	RÜCKSTRAHLER	CATADIÓPTICO		1	
11	08202P160000	STAFFA CATADIOTTRO	REFLECTOR BRACKET	BRIDE CATADIOPTRE	RÜCKSTRAHLER BÜGEL	SOPORTE CATAFAROS		1	
12	65703P160000	COPERCHIO	COVER	COUVERCLE	DECKEL	TAPA		1	
13	B0109060166H	VITE (M6X16)	SCREW (M6X16)	VIS (M6X16)	SHARAUBE (M6X16)	TORNILLO (M6X16)		1	
14	R91750031B	DADO (M6)	NUT (M6)	ECROU (M6)	MUTTER (M6)	TUERCA (M6)		10	
15	65761P16BG00	PARAFANGO POSTERIORE	REAR MUDGUARD	GARDE-BOUE ARRIÈRE	HINTERKOTFLUEGEL	GUARDABARROS TRASERO		1	
16	R320452063000	VITE (M6X25)	SCREW (M6X25)	VIS (M6X25)	SHARAUBE (M6X25)	TORNILLO (M6X25)		1	
17	R90752031B	VITE (M6X14)	SCREW (M6X14)	VIS (M6X14)	SHARAUBE (M6X14)	TORNILLO (M6X14)		5	
18	B0407060005H	DADO (M6)	NUT (M6)	ECROU (M6)	MUTTER (M6)	TUERCA (M6)		1	

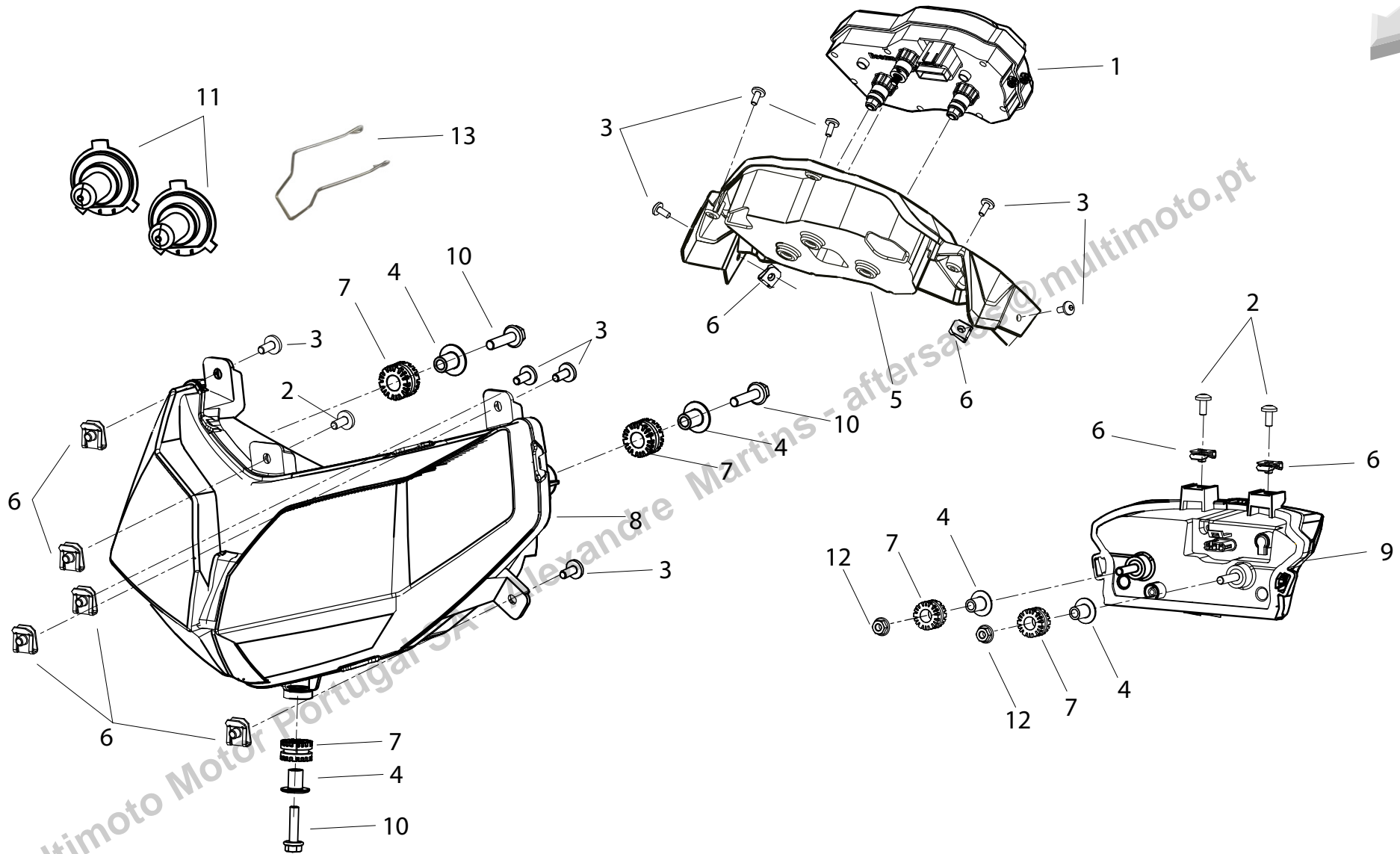

POS. NO. N. INDEX POS.	N. CODICE CODE NO. Nr. CODE ATRÍKEL N. CODICO N.	DESCRIZIONE	DESCRIPTION	DESIGNATION	BEZEICHNUNG	DENOMINACION	NOTE NOTES NOTES MARKE NOTAS	Q.TA' CONF. Q.TY PACK. Q.TE EMB. M.GE PAK. C.AD PAQ.	
1	70000P160004	STRUMENTO COMPLETO	COMPLETE INSTRUMENT PANEL	TABLEAU DE BORD COMPLET	KOMPLETTES INSTRUMENTENBRETT	TABLERO DE INSTRUMENTOS COMPLETO		1	
2	08011P160000	VITE (M5X12)	SCREW (M5X12)	VIS (M5X12)	SCHRAUBE (M5X12)	TORNILLO (M5X12)		1	
3	08012P160000	VITE (M5X16)	SCREW (M5X16)	VIS (M5X16)	SCHRAUBE (M5X16)	TORNILLO (M5X16)		1	
4	14003S040010	BOCCOLA SUPERIORE	UPPER BUSH	DOUILLE SUPÉRIEURE	OBERER BÜCHSE	CASQUILLO SUPERIOR		1	
5	65315P160000	SUPPORTO TACHIMETRO	SPEEDOMETER HOLDER	SUPPORT TACHYMÈTRE	HALTERUNG TACHOMETER	SOPORTE TAQUÍMETRO		1	
6	65624P160000	CLIP FISSAGGIO RAPIDO (M5)	QUICK FASTENING (M5)	FIXATION RAPIDE (M5)	SCHNELLEBEFESTIGUNG (M5)	FJACIÒN RÁPIDA (M5)		1	
7	R180479181000	GOMMINO	RUBBER PAD	JOINT EN CAOUTCHOUC	GUMMISTÜCK	JUNTA DE GOMA		1	
8	80000P160001	FANALE ANTERIORE	FRONT HEADLIGHT	PHARE AVANT	VORDESCHINWERFER	FARO DELANTERO		1	
9	82000P160000	FANALE POSTERIORE	REAR HEADLIGHT	PHARE ARRIÈRE	HINTERSCHINWERFER	FARO TRASERO		1	
10	R030540000000	VITE (M6X25)	SCREW (M6X25)	VIS (M6X25)	SCHRAUBE (M6X25)	TORNILLO (M6X25)		1	
11	B240137200F0	LAMPADINA (12V55W-H7)	BULB (12V55W-H7)	LAMPE (12V55W-H7)	BIRNE (12V55W-H7)	LÁMPARA (12V55W-H7)		1	
12	R030451016000	DADO (M6)	NUT (M6)	ECROU (M6)	MUTTER (M6)	TUERCA (M6)		1	
13	80110S010001	MOLLA	SPRING	RESSORT	FEDER	MUELLE		1	

PARAFANGO ANTERIORE

FRONT MUDGUARD

GARDE-BOUE AVANT

VORDERES SCHUTZBLECH

GUARDABARROS DELANTERA

TAVOLA
DRAWING
TABLE
BILD
TABLA

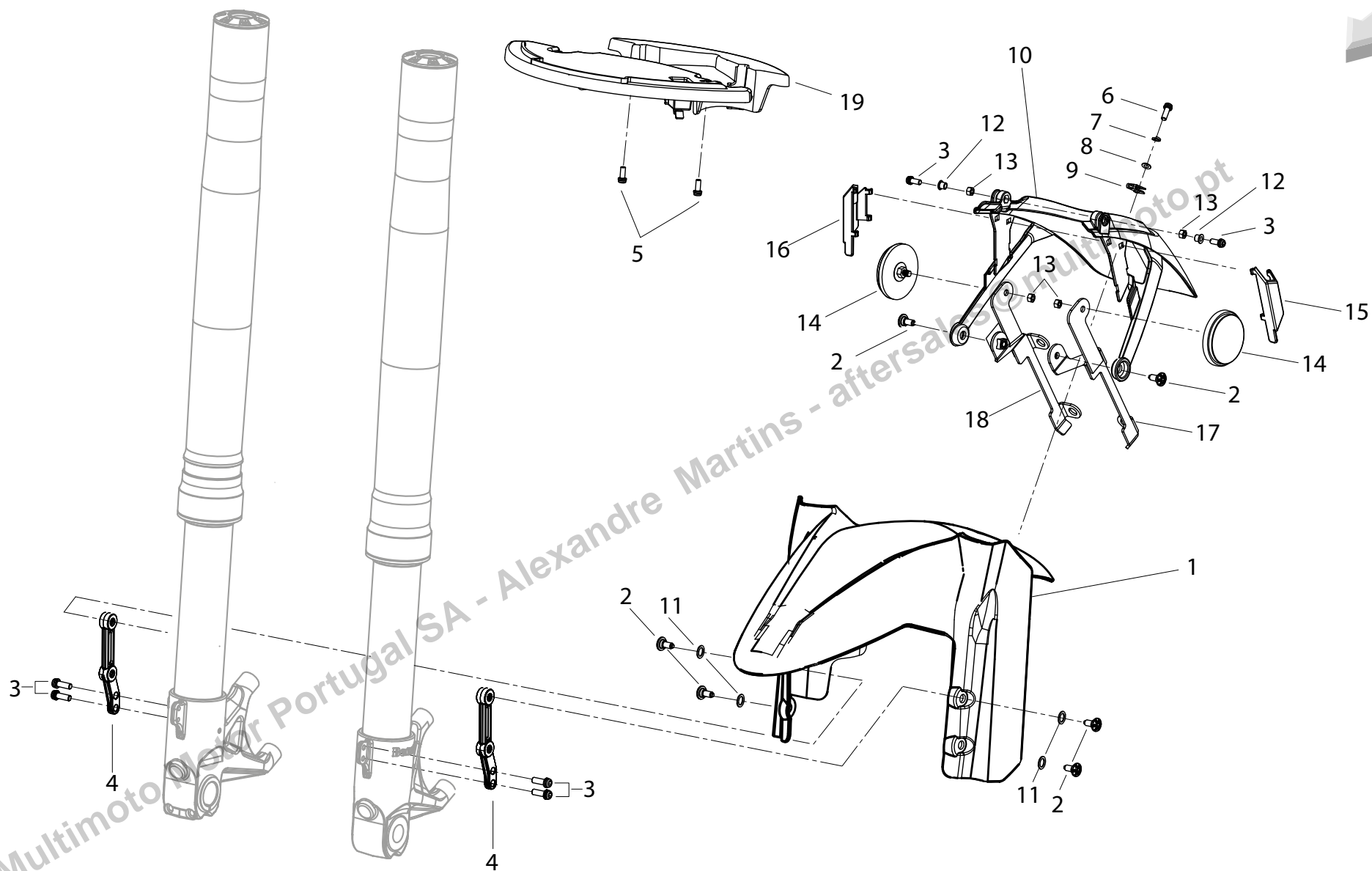

POS. NO. N. INDEX POS.	N. CODICE CODE NO. Nr. CODE ATRIKEL Nr. CODICO Nr.	DESCRIZIONE	DESCRIPTION	DESIGNATION	BEZEICHNUNG	DENOMINACION	NOTE NOTES NOTES MARKE NOTAS	Q.TA' CONF. Q.TY PACK. Q.TE EMB. M.GE PAK. C.AD PAQ.	
1	65101P160010	PARAFANGO ANTERIORE (BIANCO WS)	FRONT MUDGUARD (WHITE WS)	GARDE-BOUE AVANT (BLANC WS)	VORDERES SCHUTZBLECH (WEIB WS)	GUARDABARROS DELANTERO (BLANCO WS)		1	
1	65101P160020	PARAFANGO ANTERIORE (GRAPHITE JS)	FRONT MUDGUARD (GRAPHITE JS)	GARDE-BOUE AVANT (GRAPHITE JS)	VORDERES SCHUTZBLECH (GRAPHITE JS)	GUARDABARROS DELANTERO (GRAPHITE JS)		1	
1	65101P160030	PARAFANGO ANTERIORE (ROSSO FH)	FRONT MUDGUARD (RED FH)	GARDE-BOUE AVANT (ROUGE FH)	VORDERES SCHUTZBLECH (ROT FH)	GUARDABARROS DELANTERO (ROJO FH)		1	
1	65101P160040	PARAFANGO ANTERIORE (BLU KD)	FRONT MUDGUARD (BLUE KD)	GARDE-BOUE AVANT (BLEU KD)	VORDERES SCHUTZBLECH (BLAU KD)	GUARDABARROS DELANTERO (AZUL KD)		1	
1	65101P160050	PARAFANGO ANTERIORE (GIALLO MT)	FRONT MUDGUARD (YELLOW MT)	GARDE-BOUE AVANT (JAUNE MT)	VORDERES SCHUTZBLECH (GELB MT)	GUARDABARROS DELANTERO (AMARILLO)		1	
1	65101P16007Z	PARAFANGO ANTERIORE (BIANCO WS) CON ADESIVI	FRONT MUDGUARD (WHITE WS) WITH STICKERS	GARDE-BOUE AVANT (BLANC WS) AVEC DÉCALCOMANIE	VORDERES SCHUTZBLECH (WEIB WS) MIT AUFKLEBER	GUARDABARROS DELANT. (BLANCO WS) CON ADHESIVO		1	
1	65101P16008Z	PARAFANGO ANTERIORE (GRAPHITE JS) CON ADESIVI	FRONT MUDGUARD (GRAPHITE JS) WITH STICKERS	GARDE-BOUE AVANT (GRAPHITE JS) AVEC DÉCALCOMANIE	VORDERES SCHUTZBLECH (GRAPHITE JS) MIT AUFKLEBER	GUARDABARROS DELANT. (GRAPHITE JS) CON ADHESIVO		1	
1	65101P16009Z	PARAFANGO ANTERIORE (ROSSO FH) CON ADESIVI	FRONT MUDGUARD (RED FH) WITH STICKERS	GARDE-BOUE AVANT (ROUGE FH) AVEC DÉCALCOMANIE	VORDERES SCHUTZBLECH (ROT FH) MIT AUFKLEBER	GUARDABARROS DELANT. (ROJO FH) CON ADHESIVO		1	
1	65101P16010Z	PARAFANGO ANTERIORE (BLU KD) CON ADESIVI	FRONT MUDGUARD (BLUE KD) WITH STICKERS	GARDE-BOUE AVANT (BLEU KD) AVEC DÉCALCOMANIE	VORDERES SCHUTZBLECH (BLAU KD) MIT AUFKLEBER	GUARDABARROS DELANT. (AZUL KD) CON ADHESIVO		1	
1	65101P16011Z	PARAFANGO ANTERIORE (GIALLO MT) CON ADESIVI	FRONT MUDGUARD (YELLOW MT) WITH SITCKER	GARDE-BOUE AVANT (JAUNE MT) AVEC DÉCALCOMANIE	VORDERES SCHUTZBLECH (GELB MT) MIT AUFKLEBER	GUARDABARROS DELANT. (AMARILLO) CON ADHESIVO		1	
2	65102P16000A	SCUDO INTERNO	INNER FAIRING	CARÉNAGE INTERNE	INNENSHALE	CARENADO INTERIOR		1	
3	B02810501262	VITE (M5X0.8X12)	SCREW (M5X0.8X12)	VIS (M5X0.8X12)	SCHRAUBE (M5X0.8X12)	TORNILLO (M5X0.8X12)		5	
4	65131P160001	PIASTRA SUPPORTO PARAFANGO ESTERNA	MUDGUARD SUPPORT PLATE EXTERNAL	PLAQUE DE SUPPORT GARDE-BOUE EXTERNE	HALTEPLATTE FÜR SCHUTZBLECH EXTERN	PLANCHA SOPORTE GUARDABARROS EXTERNAS		1	
5	B02810501462	VITE (M5X0.8X14)	SCREW (M5X0.8X14)	VIS (M5X0.8X14)	SCHRAUBE (M5X0.8X14)	TORNILLO (M5X0.8X14)		5	
6	B02180501262	VITE (M5X12)	SCREW (M5X12)	VIS (M5X12)	SCHRAUBE (M5X12)	TORNILLO (M5X12)		1	
7	B0700000050A	RONDELLA ELASTICA	ELASTIC WASHER	RONDELLE ELASTIQUE	ELASTISCHER RING	ARANDELA ELÁSTICA		1	
8	B0703000050A	RONDELLA	WASHER	RONDELLE	UNTERLEGSCHIEBE	ARANDELA		1	
9	08053G120100	CLIP FISSAGGIO RAPIDO (M5)	QUIK FASTENING (M5)	FIXATION RAPIDE (M5)	SCHNELLBEFESTIGUNG (M5)	FJACIÒN RÀPIDA (M5)		1	
10	65150P160000	PARAFANGO INFERIORE	INFERIOR MUDGUARD	GARDE-BOUE INFÉRIEUR	UNTER SCHUTZBLECH	GUARDABARROS INFERIOR		1	
11	479365010000	RONDELLA NYLON	NYLON WASHER	ROSETTE EN NYLON	NYLON-UNTERLEGSCHIEBE	ARANDELA NYLON		5	
12	651055040000	BOCCOLA A "T"	BUSH "T"	DOUILLE "T"	BÜCHSE "T"	CASQUILLO "T"		1	
13	R320052121000	DADO (M5)	NUT (M5)	ECROU (M5)	MUTTER (M5)	TUERCA (M5)		1	
13	B04000600054	DADO (M6)	NUT (M6)	ECROU (M6)	MUTTER (M6)	TUERCA (M6)		1	
14	86300J000002	CATADIOTTRO	REFLECTOR	CATADIOPTRE	RÜCKSTRAHLER	CATADIÓPTRICO		1	
14	86300J000000	CATADIOTTRO (M6)	REFLECTOR (M6)	CATADIOPTRE (M6)	RÜCKSTRAHLER (M6)	CATADIÓPTRICO (M6)		1	

 **PARAFANGO ANTERIORE**

 **FRONT MUDGUARD**

 **GARDE-BOUE AVANT**

 **VORDERES SCHUTZBLECH**

 **GUARDABARROS DELANTERA**

POS. NO. N. INDEX POS.	N. CODICE CODE NO. Nr. CODE ATRIKEL Nr. CODICO Nr.	DESCRIZIONE	DESCRIPTION	DESIGNATION	BEZEICHNUNG	DENOMINACION	NOTE NOTES NOTES MARKE NOTAS	Q.TA' CONF. Q.TY PACK. Q.TE EMB. M.GE PAK. C.AD PAQ.	
15	65108P160000	PROTEZIONE IN GOMMA SINISTRA	L.H. RUBBER SEAL PROTECTOR	PROTECTION EN CAOUTCHOUC GAUCHE	GUMMISCHUTZ LINKS	PROTECCIÓN DE GOMA IZQUERDA		1	
16	65116P160000	PROTEZIONE IN GOMMA DESTRA	R.H. RUBBER SEAL PROTECTOR	PROTECTION EN CAOUTCHOUC DROITE	GUMMISCHUTZ RECHTES	PROTECCIÓN DE GOMA DERECHA		1	
17	65141P160001	PIASTRA SUPPORTO PARAFANGO	MUDGUARD SUPPORT PLATE	PLAQUE DE SUPPORT GARDE-BOUE	HALTEPLATTE FÜR SCHUTZBLECH	PLANCHA SOPORTE GUARDABARROS		1	
18	B0284060150A	VITE (M6X15.2)	SCREW (M6X15.2)	VIS (M6X15.2)	SCHRAUBE (M6X15.2)	TORNILLO (M6X15.2)		5	
19	08011P160000	VITE (M5X12)	SCREW (M5X12)	VIS (M5X12)	SCHRAUBE (M5X12)	TORNILLO (M5X12)		1	



Multimoto Motor Portugal SA - Alexandre Martins - aftersales@multimoto.pt

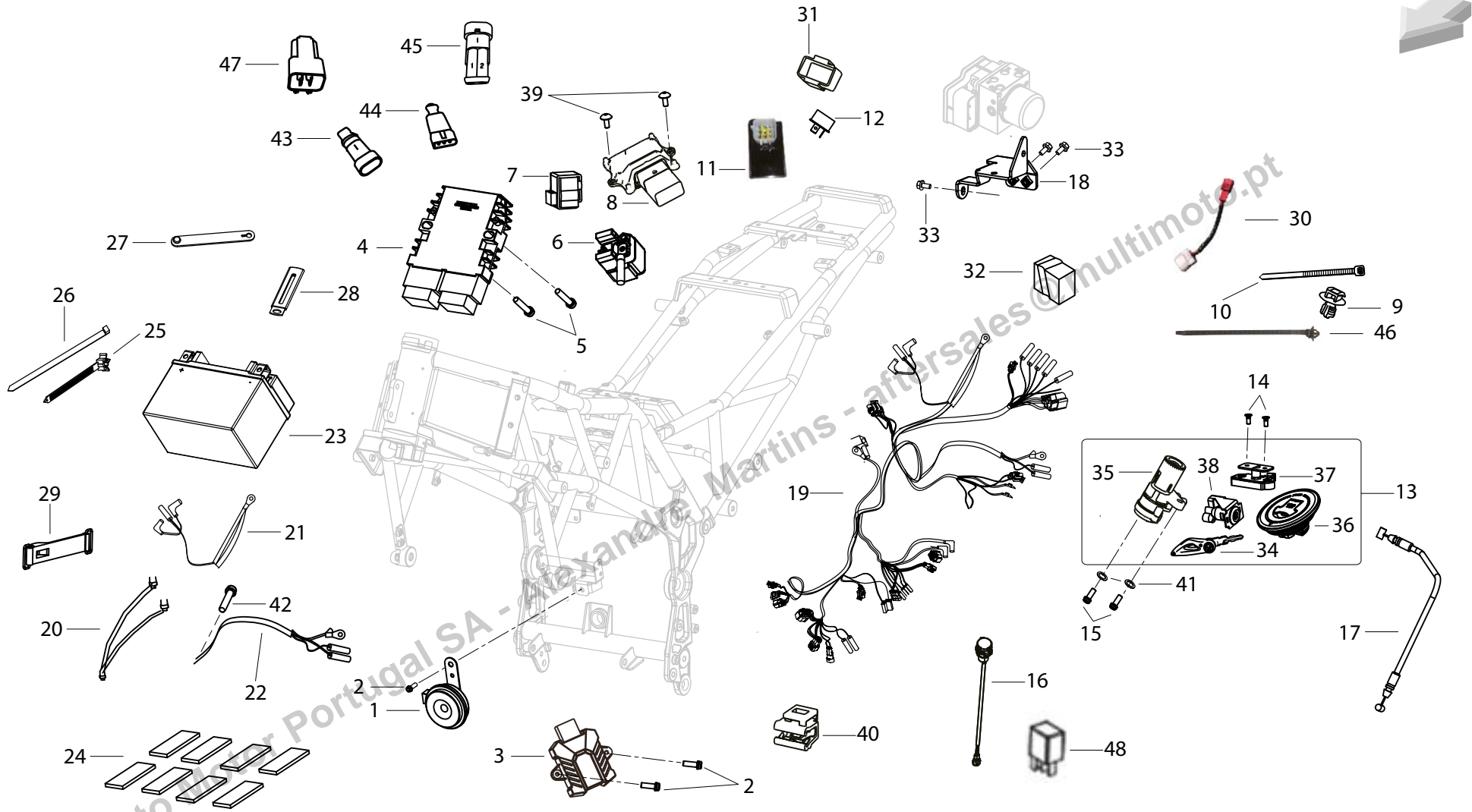

POS. NO. N. INDEX POS.	N. CODICE CODE NO. Nr. CODE ATRIKEL Nr. CODICO Nr.	DESCRIZIONE	DESCRIPTION	DESIGNATION	BEZEICHNUNG	DENOMINACION	NOTE NOTES NOTES MARKE NOTAS	Q.TA' CONF. Q.TY PACK. Q.TE EMB. M.GE PAK. C.AD PAQ.	
1	95100P160001	AVVISATORE ACUSTICO	HORN	KLAXON	HUPE	CLAXON		1	
2	R90751421B	VITE (TCEI M8X16)	SCREW (TCEI M8X16)	VIS (TCEI M8X16)	SHARAUBE (TCEI M8X16)	TORNILLO (TCEI M8X16)		5	
3	96350P150000	CENTRALINA ELETTRONICA CAN-BUS	ELECTRONIC CONTROL UNIT CAN-BUS	CENTRALE ELECTRONIQUE CAN-BUS	ELEKTRONISCHE STEUEREINHEIT CAN-BUS	CENTRALITA ELECTRÓNICA CAN-BUS		1	
4	299066060000	REGOLATORE DI TENSIONE	VOLTAGE REGULATOR	REGULATEUR DE TENSION	SPANNUNGSREGLER	REGULADOR DE TENSION		1	
5	R020051103000	VITE (M6X30)	SCREW (M6X30)	VIS (M6X30)	SHARAUBE (M6X30)	TORNILLO (M6X30)		1	
6	94000S010000	RELAIS AVVIAMENTO	RELAY START	RELAIS DÉBUT	RELAIS ANFANG	RELÉ COMIENZO		1	
7	R320077045000	SENSORE DI SPEGNIMENTO	SWITCH OF ENGINE SENSOR	CAPTEUR ÉTEINDRE MOTEUR	SENSOR LÖSCHEN MOTOR	SENSOR EXTINGUIR MOTOR		1	
8	96C00P160001	CENTRALINA INIEZIONE	INJECTION CONTROL UNIT	CENTRALE INJECTION	STEUERGEHÄUSE DER EINSPRITZUNG	CENTRALITA INYECCIÓN		1	
9	96001P160000	CHIODO RAPIDO	QUIK NAIL	ONGLE RAPIDE	NAGELSCHNELLE	CLAVO RÁPIDO		1	
10	96003P360000	FASCETTA A VITE	SCREW HOSE CLAMP	COLLIER À VISSER	SCHRAUBENSHELLE	ABRAZADERA A TORNILLO		1	
11	96400H390001	INTERMITTENZA	FLASHER	INTERMITENCE	BLINKGEBER	INTERMITENCIA		1	
12	96700K060000	DIODO	DIODE	DIODE	DIODE	DIODO		1	
13	88000P160001	GRUPPO SERRATURE	LOCKS KIT	JEU SERRURE	SCHLOBGRUPPE	GRUPO CERRADURAS		1	
14	B02010602525	VITE (M6X25)	SCREW (M6X25)	VIS (M6X25)	SHARAUBE (M6X25)	TORNILLO (M6X25)		1	
15	B0226080206H	VITE (M8X20)	SCREW (M8X20)	VIS (M8X20)	SHARAUBE (M8X20)	TORNILLO (M8X20)		5	
16	92950H380001	PRESA USB	JACK USB	JACK USB	JACK USB	JACK USB		1	
17	58900P160000	CAVO APERTURA SELLA	CABLE OPENING SEAT	CÂBLE OUVERTURE SELLE	SATTELÖFFNUNGSKABEL	CABLE ABERTURA SILLIN		1	
18	58670P160000	STAFFA	BRACKET	BRIDE	BÜGEL	SOPORTE		1	
19	92000P16000J	CABLAGGIO PRINCIPALE	MAIN WIRING	CÂBLAGE PRINCIPAL	HAUPTKABEL	CABLEADO PRINCIPAL		1	
20	92300P160000	CAVO DI MASSA	GROUNDING CABLE	CÂBLE MASSE	MASSEKABEL	CABLE TIERRA		1	
21	92200P160000	CABLAGGIO BATTERIA	BATTERY WIRING	CÂBLAGE BATTERIE	VERKABELUNG BATTERIE	CABLEADO BATERÍA		1	
22	92500P160000	CAVO DI MASSA	GROUNDING CABLE	CÂBLE MASSE	MASSEKABEL	CABLE TIERRA		1	
23	96100P160000	BATTERIA	BATTERY	BATTERIE	BATTERIE	BATERÍA		1	
24	58752P250000	TAMPONE	PAD	TAMPON	STOPFEN	APOYO		1	

POS. NO. N. INDEX POS.	N. CODICE CODE NO. Nr. CODE ATRIKEL Nr. CODICO Nr.	DESCRIZIONE	DESCRIPTION	DESIGNATION	BEZEICHNUNG	DENOMINACION	NOTE NOTES NOTES MARKS NOTAS	Q.TA' CONF. Q.TY PACK. M.GE EMB. C.AD PAK. C.AD PAQ.	
25	R700052186000	FASCETTA	CLAMP	COLLIER	SHELLE	ABRAZADERA		5	
26	40098B450000	FASCETTA	CLAMP	COLLIER	SHELLE	ABRAZADERA		1	
27	96003P250000	FASCETTA IN GOMMA	RUBBER HOSE CLAMP	COLLIER EN CAOUTCHOUC	GUMMISHELLE	ABRAZADERA EN GOMA		1	
28	R700068083000	PASSACAVO	FAIRLEAD	PASSE-CÂBLE	KABELDURCHFÜHRUNG	PASA-CABLE		1	
29	02200J0000A0	CINGHIA BATTERIA	BAND BATTERY	COURROIE BATTERIE	KEILRIEMEN, BATTERIE	CORREA BATERIA		1	
30	92940P060000	CAVO DIAGNOSI NEW OBD	CABLE DIAGNOSIS NEW OBD	CÂBLE DIAGNOSIS NEW OBD	KABEL DIAGNOSIS NEW OBD	CABLE DE DIAGNOSIS NEW OBD		1	
31	96007B720001	GOMMINO SUPPORTO INTERMITTENZA	RUBBER PAD HOLDER FLASHER	JOINT EN CAOUTCHOUC SUPPORT INTERMITENCE	GUMMISTÜCK HALTERUNG BLINKGEBER	JUNTA DE GOMA SOPORTE INTERMITENCIA		1	
32	R300077150000	GOMMINO SUPPORTO SENSORE DI SPEGNIMENTO	RUBBER PAD HOLDER SWITCH OF ENGINE SENSOR	JOINT EN CAOUTCHOUC SUPPORT CAPTEUR ÉTEINDRE MOTEUR	GUMMISTÜCK HALTERUNG SENSOR LÖSCHEN MOTOR	JUNTA DE GOMA SOPORTE SENSOR EXTINGUIR MOTOR		1	
33	R700052157000	VITE (M6X16)	SCREW (M6X16)	VIS (M6X16)	SHARAUBE (M6X16)	TORNILLO (M6X16)		5	
34	88900P160001	CHIAVE NEUTRA	KEY BLANK	CLÈ VIDE	SCHLUSSEL LEER	LLAVE EN BLANCO		1	
35	88100P160001	SERRATURA BLOCCASTERZO	STEERING LOCK	SERRURE BLOQUEO DE DIRECCIÓN	LENKSCLOSS	CERRADURAS BLOQUEO DE DIRECCIÓN		1	
36	88400P160001	TAPPO SERBATOIO CARBURANTE	FUEL TANK CAP	BOUCHON RÉSERVOIR CARBURANT	TANKVERSCHLUß BENZIN	TAPÓN DEPÓSITO COMBUSTIBLE		1	
37	R180266102000	LEVA APERTURA SELLA	SEAT LEVER	LEVIER DE SELLE	SITZBANKHEBEL	PALANCA ABERTURA SILLÍN		1	
38	88800P160001	SERRATURA SELLA	SEAT LOCK	SERRURE SELLE	SATTELSCHLOß	CERRADURA SILLÍN		1	
39	R90750401B	VITE (M5X0.8X14)	SCREW (M5X0.8X14)	VIS (M5X0.8X14)	SCHRAUBE (M5X0.8X14)	TORNILLO (M5X0.8X14)		5	
40	96010P160000	TAMPONE IN GOMMA	RUBBER PAD	TAMPON EN CAOUTCHOUC	GUMMISTOPFEN	APOYO DE GOMA		1	
41	B0700000080H	RONDELLA ELASTICA	ELASTIC WASHER	RONDELLE ELASTIQUE	ELASTISCHER RING	ARANDELA ELÁSTICA		1	
42	08013P100000	VITE (M6X16)	SCREW (M6X16)	VIS (M6X16)	SHARAUBE (M6X16)	TORNILLO (M6X16)		10	
43	96600P180000	RESISTENZA	RESISTOR	RÉSISTANCE	WIDERSTAND	RESISTOR		1	
44	96700P100000	DIODO	DIODE	DIODE	DIODE	DIODO		1	
45	92058P060000	CONNETTORE ABS	ABS CONNECTOR	CONNECTEUR ABS	STECKER ABS	CONECTOR ABS		1	
46	96001N350000	FASCETTA	CLAMP	COLLIER	SHELLE	ABRAZADERA		1	
47	92059P060000	INTERFACCIA IOT	INTEFACE IOT	INTEFACE IOT	SCHNITTSTELLE IOT	INTERFAZ IOT		1	
48	92039S010000	RELAIS CONTROLLO LUCI	RELAY BULB	RELAIS LAMPE	RELAIS BIRNE	RELÉ LÁMPARA		1	

 **MANIGLIONE POSTERIORE**

 **REAR HANDLE**

 **POIGNÉE ARRIÈRE**

 **GRIFF HINTEN**

 **MANIJA TRASERO**

TAVOLA
DRAWING
TABLE
BILD
TABLA

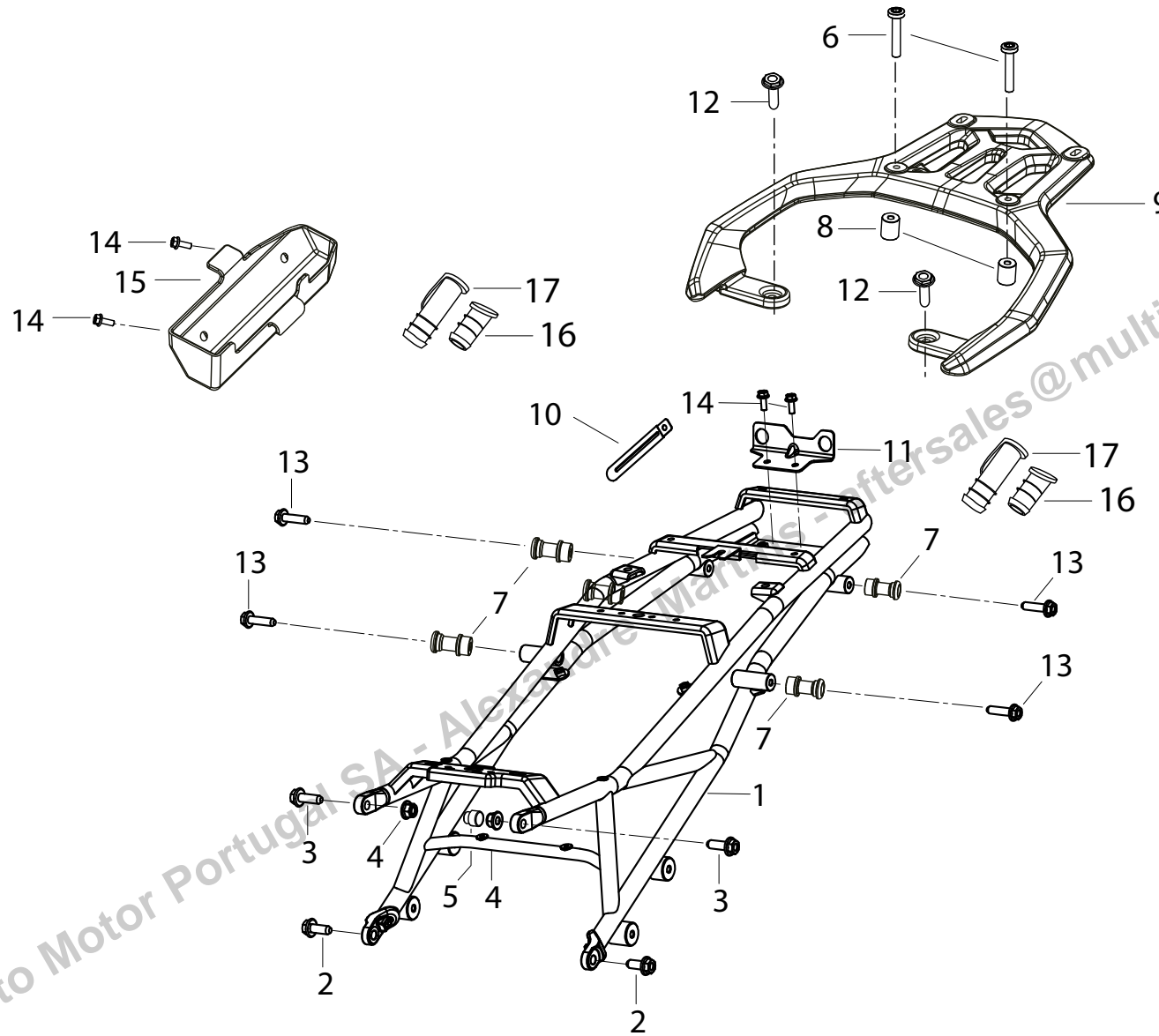

POS. NO. N. INDEX POS.	N. CODICE CODE NO. Nr. CODE ATRÍKEL Nr. CODICO Nr.	DESCRIZIONE	DESCRIPTION	DESIGNATION	BEZEICHNUNG	DENOMINACION	NOTE NOTES NOTES MARKE NOTAS	Q.TA' CONF. Q.TY PACK. Q.TE EMB. M.GE PAK. C.AD PAQ.	
1	57120P16010A	TELAIO POSTERIORE	REAR FRAME	CADRE ARRIERE	RAHMEN HINTERRAD	CHASIS TRASERO	NERO	1	
2	B0109100256H	VITE (M10X25)	SCREW (M10X25)	VIS (M10X25)	SCHRAUBE (M10X25)	TORNILLO (M10X25)	ARGENTO	1	
3	B0159100306H	VITE (M10X30)	SCREW (M10X30)	VIS (M10X30)	SCHRAUBE (M10X30)	TORNILLO (M10X30)	ARGENTO	1	
4	B0417101254H	DADO (M10)	NUT (M10)	ECROU (M10)	MUTTER (M10)	TUERCA (M10)	ARGENTO	1	
5	58306P160000	TAPPO	CAP	BOUCHON	VERSCHLUB	TAPÓN		1	
6	B0109080606H	VITE (M8X60)	SCREW (M8X60)	VIS (M8X60)	SCHRAUBE (M8X60)	TORNILLO (M8X60)		4	
7	51022P160000	BOCCOLA	BUSH	DOUILLE	BUCHSE	CASQUILLO		1	
8	52511H240100	BOCCOLA	BUSH	DOUILLE	BUCHSE	CASQUILLO		1	
9	52011P16BG00	MANIGLIONE POSTERIORE	REAR HANDLE	POIGNÉE ARRIÈRE	GRIFF HINTEN	MANIJA TRASERO		1	
10	R320052109000	FASCETTA ELASTICA	SPRING CLAMP	COLLIER ÉLASTIQUE	ELASTISCHE SCHELLE	ABRAZADERA ELÁSTICA		1	
11	08301P160000	PIASTRINO	PLATE	PLAQUETTE	PLÄTTCHEN	LÁMINA		1	
12	B0109080206H	VITE (M8X20)	SCREW (M8X20)	VIS (M8X20)	SHARAUBE (M8X20)	TORNILLO (M8X20)		1	
13	B0205080456H	VITE (M8X45)	SCREW (M8X45)	VIS (M8X45)	SHARAUBE (M8X45)	TORNILLO (M8X45)		1	
14	B01090601264	VITE (M6X12)	SCREW (M6X12)	VIS (M6X12)	SHARAUBE (M6X12)	TORNILLO (M6X12)		1	
15	02131P160000	VANO PORTA ATTREZZI	TOOLS BOX	BOÎTE À OUTILS	WERKZEUGKASTEN	CAJA DE HERRAMIENTAS		1	
16	57015P160000	TAPPO TELAIO	FRAME PLUG	BOUCHON CADRE	RAHMEN-STECKER	TAPÓN CHASIS		1	
17	57016P160000	TAPPO TELAIO	FRAME PLUG	BOUCHON CADRE	RAHMEN-STECKER	TAPÓN CHASIS		1	

FOR WHITE MODEL

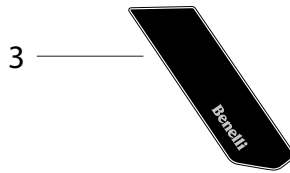
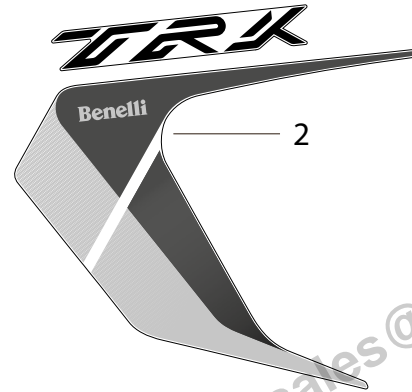
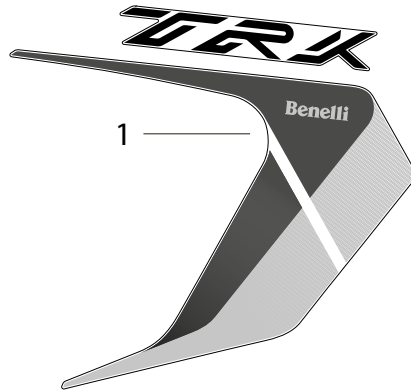

6

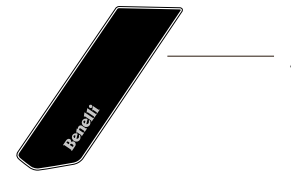

5

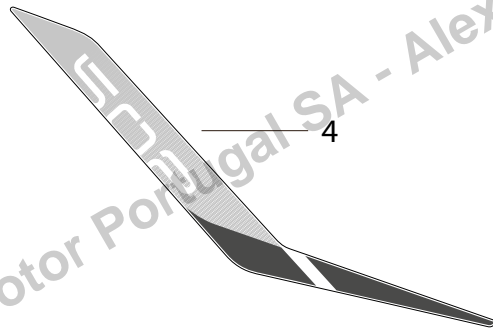

4

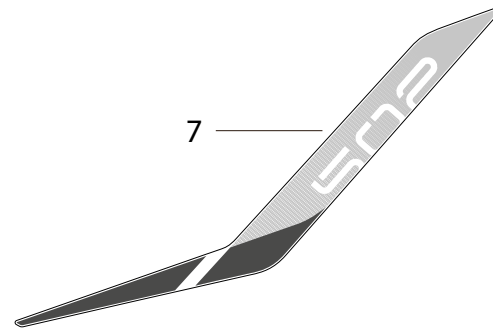

7



POS. NO. N. INDEX POS.	N. CODICE CODE NO. Nr. CODE ATRIKEL Nr. CODICO Nr.	DESCRIZIONE	DESCRIPTION	DESIGNATION	BEZEICHNUNG	DENOMINACION	NOTE NOTES NOTES MARKE NOTAS	Q.TA' CONF. Q.TY PACK. Q.TE EMB. M.GE PAK. C.AD PAQ.	
1	05512P16WS04	ADESIVO DX	STICKER R.H.	DÉCALCOMANIE DROITE	AUFKLEBER RECHTER	ADHESIVO DERECHO		1	
2	05511P16WS04	ADESIVO SX	L.H. STICKER	DÉCALCOMANIE GAUCHE	AUFKLEBER LINKER	ADHESIVO IZQUIERDA		1	
3	05502P16WS04	ADESIVO PARAFANGO ANTERIORE DESTRO	RIGHT FRONT FENDER MARK	DÉCALCOMANIE GARDE-BOUE AVANT DROITE	ABZIEHBILD VORDERES KOTFLUGEL, RECHTS	ADHESIVO GUARDBARROS DELANTERO DERECHO		1	
4	05572P16WS04	ADESIVO CARENA DESTRA	R.H. STICKER LOWER FAIRING	DÉCALCOMANIE CARÈNE LATERAL DROIT	ABZIEHBILD RECHTE SEITENABDECKUNG	ADHESIVO TAPA LATERAL DERECHA		1	
5	05501P16WS04	ADESIVO SX	L.H. STICKER	DÉCALCOMANIE GAUCHE	AUFKLEBER LINKER	ADHESIVO IZQUIERDA		1	
6	05533P16WS04	ADESIVO LOGO "BENELLI"	STICKER "BENELLI"	DÉCALCOMANIE "BENELLI"	ABZIEHBILD "BENELLI"	ADHESIVO "BENELLI"		1	
7	05571P16WS04	ADESIVO SX	L.H. STICKER	DÉCALCOMANIE GAUCHE	AUFKLEBER LINKER	ADHESIVO IZQUIERDA		1	



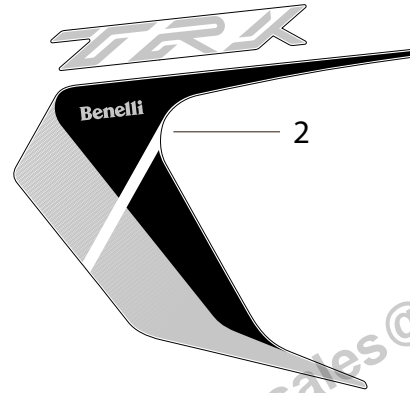
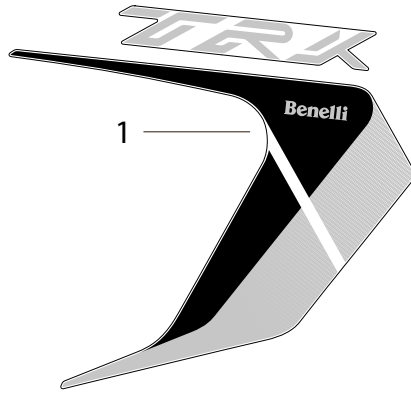

FOR GREY MODEL
FOR RED MODEL
FOR BLUE MODEL

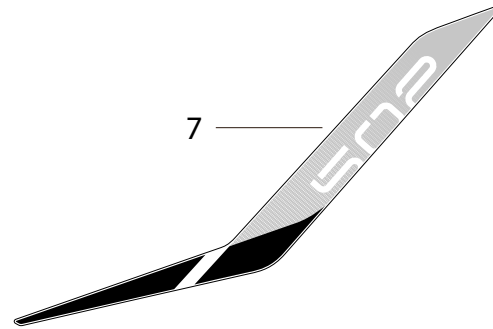
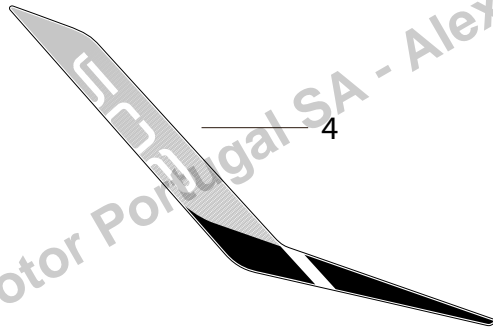
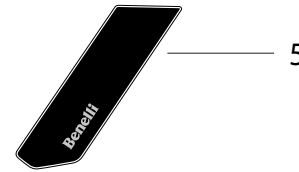
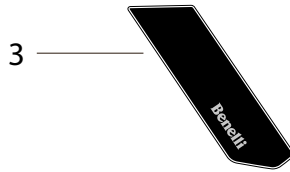

POS. NO. N. INDEX POS.	N. CODICE CODE NO. Nr. CODE ATRIKEL Nr. CODICO Nr.	DESCRIZIONE	DESCRIPTION	DESIGNATION	BEZEICHNUNG	DENOMINACION	NOTE NOTES NOTES MARKE NOTAS	Q.TA' CONF. Q.TY PACK. Q.TE EMB. M.GE PAK. C.AD PAQ.	
1	05512P16JS04	ADESIVO DX	STICKER R.H.	DÉCALCOMANIE DROITE	AUFKLEBER RECHTER	ADHESIVO DERECHO		1	
2	05511P16JS04	ADESIVO SX	L.H. STICKER	DÉCALCOMANIE GAUCHE	AUFKLEBER LINKER	ADHESIVO IZQUIERDA		1	
3	05502P16WS04	ADESIVO PARAFANGO ANTERIORE DESTRO	RIGHT FRONT FENDER MARK	DÉCALCOMANIE GARDE-BOUE AVANT DROITE	ABZIEHBILD VORDERES KOTFLUGEL, RECHTS	ADHESIVO GUARDBARROS DELANTERO DERECHO		1	
4	05572P16JS04	ADESIVO CARENA DESTRA	R.H. STICKER LOWER FAIRING	DÉCALCOMANIE CARÈNE LATERAL DROIT	ABZIEHBILD RECHTE SEITENABDECKUNG	ADHESIVO TAPA LATERAL DERECHA		1	
5	05501P16WS04	ADESIVO SX	L.H. STICKER	DÉCALCOMANIE GAUCHE	AUFKLEBER LINKER	ADHESIVO IZQUIERDA		1	
6	05533P16JS04	ADESIVO LOGO "BENELLI"	STICKER "BENELLI"	DÉCALCOMANIE "BENELLI"	ABZIEHBILD "BENELLI"	ADHESIVO "BENELLI"		1	
7	05571P16JS04	ADESIVO SX	L.H. STICKER	DÉCALCOMANIE GAUCHE	AUFKLEBER LINKER	ADHESIVO IZQUIERDA		1	



Benelli Q.J. s.r.l.

Strada della Fornace Vecchia, sn
61122 Pesaro Italy / Tel. +39 0721 41871 Fax +39 0721 418722
support@benelli.com / www.benelli.com / www.benellishop.com



Benelli Q.J. srl si riserva il diritto di modificare le caratteristiche tecniche, dotazioni, allestimenti e colori senza obbligo di preavviso.
Benelli Q.J. srl reserves the right to change technical specification, equipment, set up and colours without prior notice.

